



PROCEDURE FOR ADAPTING THE PID PARAMETERS FOR *Fast-PS*, *Fast-PS-IK5*, *Fast-PS-M*, AND *NGPS*

Pre-Information

All CAEN ELS power source are digitally controlled. This means that an adaptation to any load can be achieved simply by changing the Software PID-Parameters.

Fast-PS, *Fast-PS-IK5*, *Fast-PS-M* and *NGPS* power supplies have a control loop that continuously controls current. Current Control Loop and Voltage Control Loop diagram is hereafter presented:

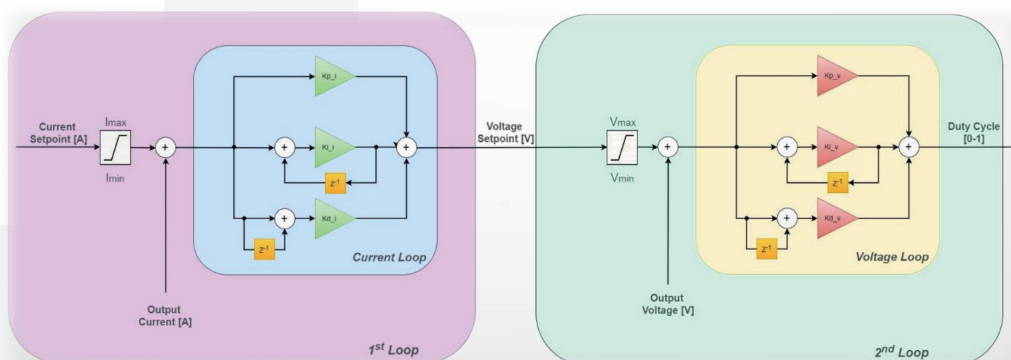

The PID-parameters consist in 12 values that can be input through the web-server interface: 6 values, Kp_v , Ki_v , Kd_v , Kp_i , Ki_i and Kd_i , used when the **CC** (constant current) is selected, and 6 values, Kp_v , Ki_v , Kd_v , Kp_i , Ki_i , and Kd_i , when **CV** (constant voltage) is set:

Constant Current (CC)

Name	Value	Is Editable
Double CC loop *	<input type="checkbox"/>	🔒 (RESERVED)
Kp_v (Proportional term - Voltage Loop)	0.00012	🔒
Ki_v (Integral term - Voltage Loop) *	0.0028	🔒
Kd_v (Derivative term - Voltage Loop)	0.000	🔒
Kp_i (Proportional term - Current Loop)	0.0001	🔒
Ki_i (Integral term - Current Loop) *	0.0001	🔒
Kd_i (Derivative term - Current Loop) *	0.0001	🔒
Max Output Voltage [V] *	22	🔒
Min Output Voltage [V] *	-22	🔒

Constant Voltage (CV)

Name	Value	Is Editable
Double CV loop **	<input type="checkbox"/>	🔒 (RESERVED)
Kp_v (Proportional term - Voltage Loop)	0.00012	🔒
Ki_v (Integral term - Voltage Loop) *	0.0028	🔒
Kd_v (Derivative term - Voltage Loop)	0.000	🔒
Kp_i (Proportional term - Current Loop)	0.0001	🔒
Ki_i (Integral term - Current Loop) *	0.0001	🔒
Kd_i (Derivative term - Current Loop) *	0.0001	🔒
Max Output Voltage [V] *	22	🔒
Min Output Voltage [V] *	-22	🔒



PID PARAMETER ADAPTATION



Target is to adapt PID values for a specific load connected to a CAEN ELS power supplies that it is performing in an ideal way: Fast Rise Times, No Overshoot (or small Overshoot), No Oscillations.

UNWANTED STEP RESPONSE:



DESIDERABLE STEP RESPONSE:

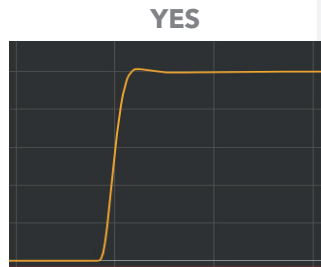

Due to safety concerns for both the source and the load, caused by potential dangerous high-frequency oscillations, the PID parameters should be set to very low values at the beginning of each adaptation for an unknown load.

To proceed follow these steps:

1. It is recommended to start with these parameters (safe side):

$$\mathbf{Kp_v = Ki_v = Kp_i = Ki_i = 0.00001 \text{ and } Kd_v = Kd_i = 0}$$

2. (Kd typically should not to be changed due to its minor influence on the result. Only in very special cases with expectionally high demands , such as with superconducting magnets, might it be adjust).
3. During PID adaptation procedure, set current and voltage to approximately 10% of the nominal value.
(i.e. if the PS is a 20 A - 20 V model set Current and Voltage from 0 to 2A/2V).

ATTENTION: The PID parameters are specific to each power source series. For example, it is not possible to use the same parameters for a Fast-Ps 052001 that were determined for a Fast-Ps 058004 or for different power supply families!

PID PARAMETER ADAPTATION

Open the **Device Manager** main menu from web server:

- Enter the Password (ps-admin) to log in with administrator privileges.
- Click on **Config**, then on **PID** to access the **CV** and **CC** modes.
- From the two drop-down menu, start with **CV** mode.

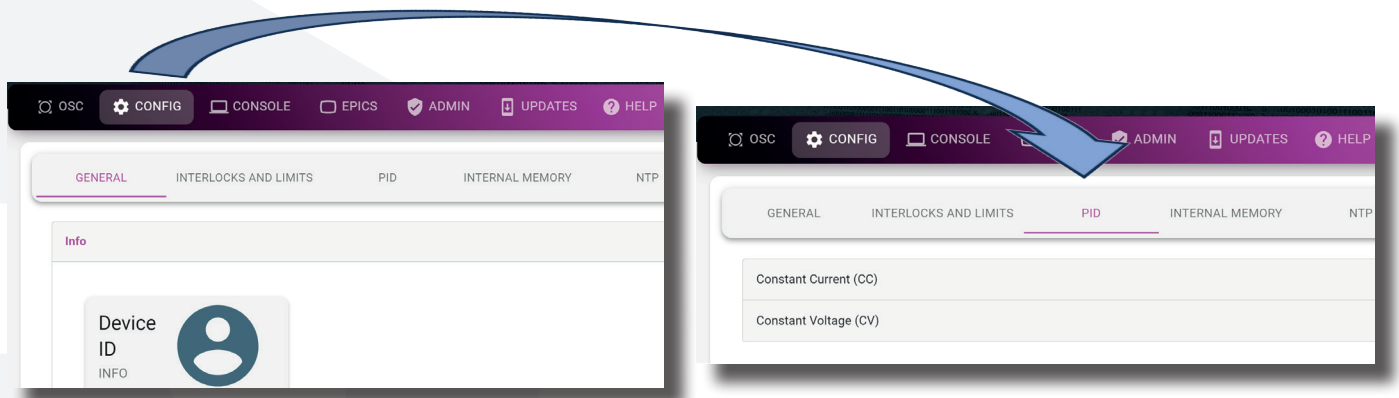

CV-Mode -Voltage Loop

Following the **Voltage Control Loop Adaption** flowchart:

- Adapt the **Kp_v** parameter for the Voltage Loop.
- Adapt the **Ki_v** parameter for the Voltage Loop.

Name	Value	Is Editable
Double CV loop **	<input type="checkbox"/>	(RESERVED)
Kp_v (Proportional term - Voltage Loop)	0.00012	
Ki_v (Integral term - Voltage Loop) *	0.0028	
Kd_v (Derivative term - Voltage Loop)	0.000	
Kp_i (Proportional term - Current Loop)	0.0001	
Ki_i (Integral term - Current Loop) *	0.0001	
Kd_i (Derivative term - Current Loop) *	0.0001	
Max Output Voltage [V] *	22	
Min Output Voltage [V] *	-22	

PID PARAMETER ADAPTATION

- Transfer the acquired **CV** Mode - Voltage Loop parameters into the **CC** Mode - Voltage Loop.

GENERAL INTERLOCKS AND LIMITS **PID** INTERNAL MEMORY NTP

Constant Current (CC)

Name	Value	Is Editable
Double CC loop *	<input type="checkbox"/>	(RESERVED)
Kp_v (Proportional term - Voltage Loop)	0.00012	
Ki_v (Integral term - Voltage Loop) *	0.0028	
Kd_v (Derivative term - Voltage Loop)	0.000	
Kp_i (Proportional term - Current Loop)	0.0001	
Ki_i (Integral term - Current Loop) *	0.0001	
Kd_i (Derivative term - Current Loop) *	0.0001	
Max Output Voltage [V] *	22	
Min Output Voltage [V] *	-22	

CC-Mode -Current Loop

Following the **Current Control Loop Adaption** flowchart:

- Adapt the **Kp_i** parameter for the Current Loop.
- Adapt the **Ki_i** parameter for the Current Loop.

GENERAL INTERLOCKS AND LIMITS **PID** INTERNAL MEMORY NTP

Constant Current (CC)

Name	Value	Is Editable
Double CC loop *	<input type="checkbox"/>	(RESERVED)
Kp_v (Proportional term - Voltage Loop)	0.00012	
Ki_v (Integral term - Voltage Loop) *	0.0028	
Kd_v (Derivative term - Voltage Loop)	0.0001	
Kp_i (Proportional term - Current Loop)	0.0016	
Ki_i (Integral term - Current Loop) *	0.0003	
Kd_i (Derivative term - Current Loop) *	0.000	
Max Output Voltage [V] *	22	
Min Output Voltage [V] *	-22	

PID PARAMETER ADAPTATION

- Transfer the acquired **CC** Mode - Current Loop parameters into the **CV** Mode - Current Loop.

The screenshot shows the PID configuration interface with the 'PID' tab selected. The 'Constant Voltage (CV)' mode is active. The following table lists the parameters:

Name	Value	Is Editable
Double CV loop **	<input type="checkbox"/>	(RESERVED)
Kp_v (Proportional term - Voltage Loop)	0.00012	
Ki_v (Integral term - Voltage Loop) *	0.0028	
Kd_v (Derivative term - Voltage Loop)	0.0001	
Kp_i (Proportional term - Current Loop)	0.0016	
Ki_i (Integral term - Current Loop) *	0.0003	
Kd_i (Derivative term - Current Loop) *	0.000	
Max Output Voltage [V] *	22	
Min Output Voltage [V] *	-22	

- Press the **Apply** button to save the values into the internal memory.

The screenshot shows the bottom of the PID configuration interface. The 'PID' tab is selected. Below the configuration table, there are several buttons and a checkbox:

- Load PID Configuration
-
-
-
-

PID PARAMETER ADAPTATION

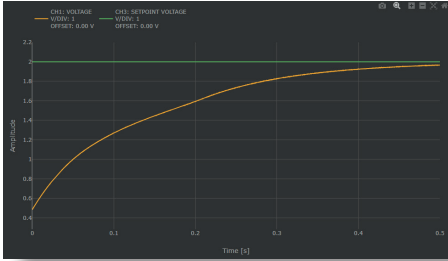

Fig. A

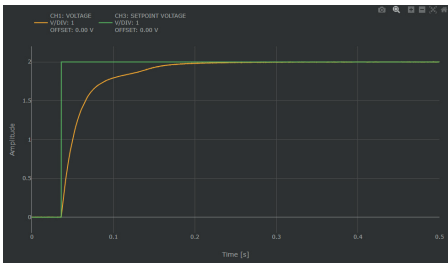

Fig. B

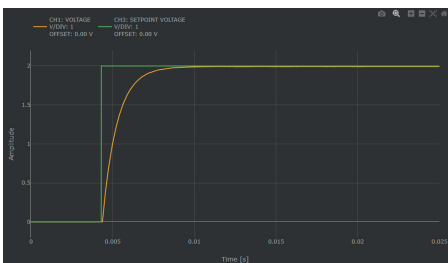
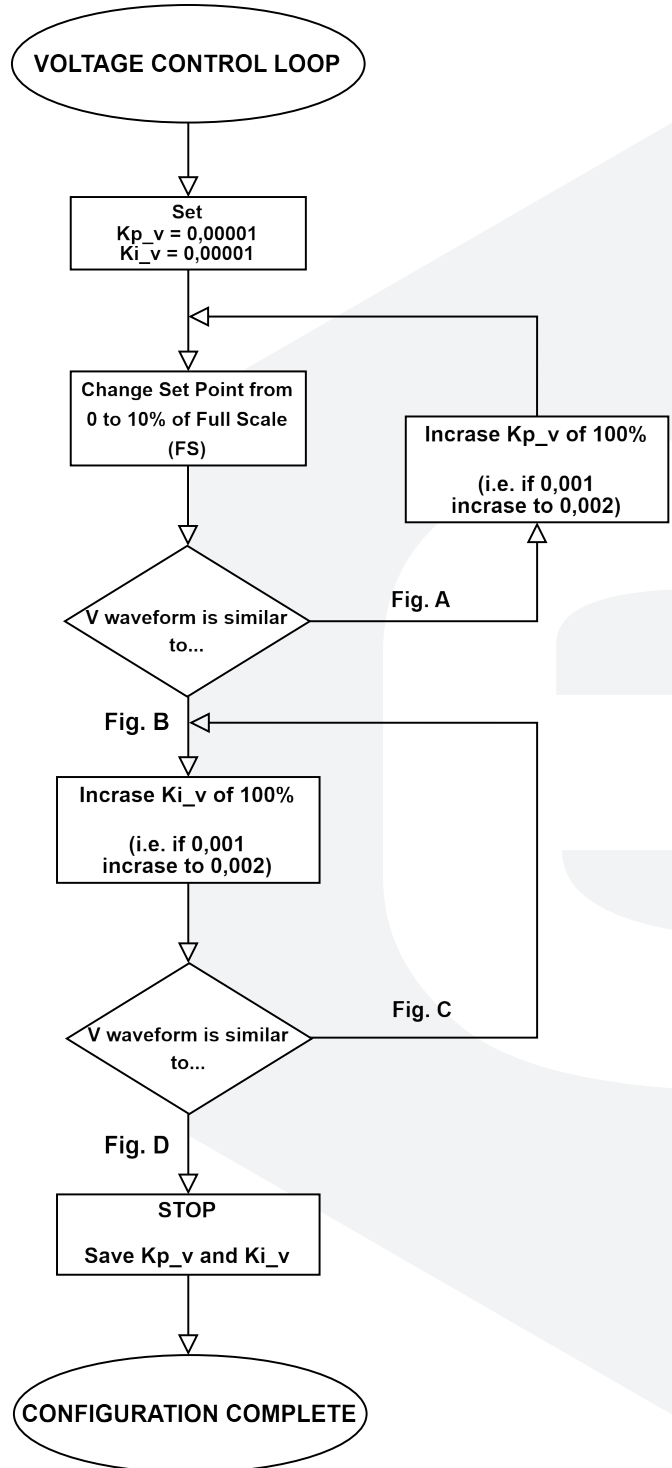

Fig. C



Fig. D



NOTE: In some cases when Fig.D is obtained, a further increase of Kp may reduce the voltage overshoot.

PID PARAMETER ADAPTATION

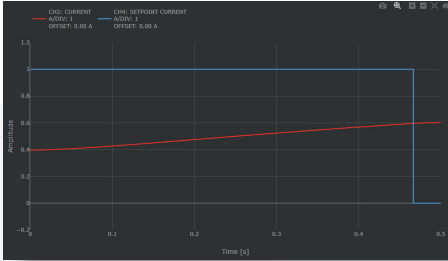

Fig. A

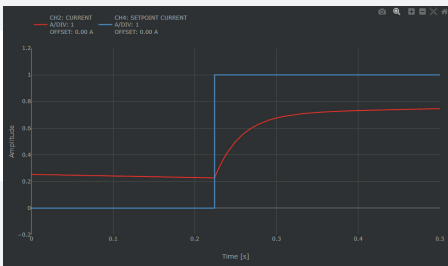

Fig. B

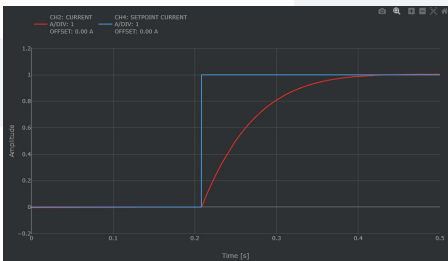

Fig. C

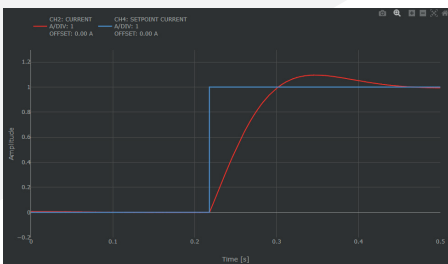
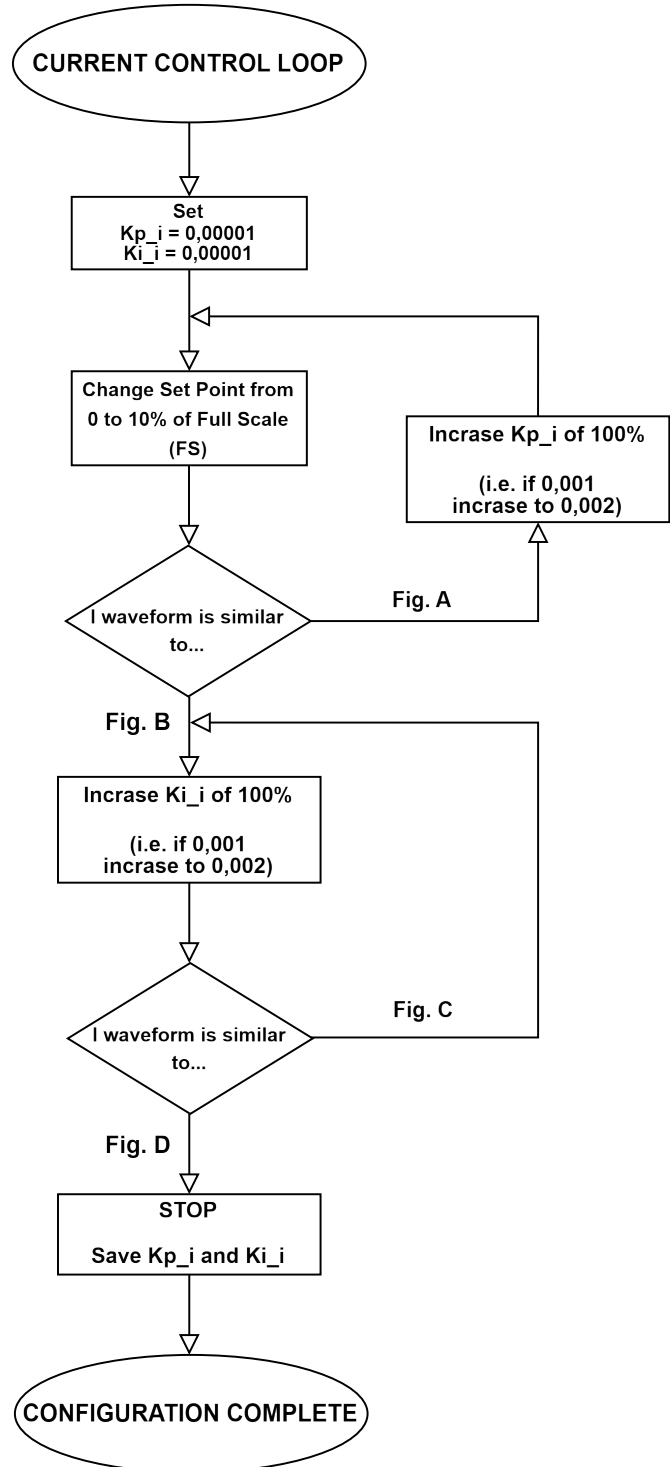

Fig. D







NOTE: In some cases when Fig.D is obtained, a further increase of Kp may reduce the current overshoot.

PID PARAMETER ADAPTATION



About Us

ELS Instruments (formerly CAEN ELS) is a leading company in the design of power supplies and state-of-the-art complete electronic systems for the Physics research world, having its main focus on dedicated solutions for the particle accelerator community and high-end industrial applications.

-  Power Supply Systems
-  Precision Current Measurements
-  Beamline Electronics Instrumentation
-  FMC and MicroTCA

ELS Instruments srl

Via Karl Ludwig von Bruck 32
34144 - Trieste (TS) Italy

info@caenels.com

www.els-instruments.com

www.caenels.com

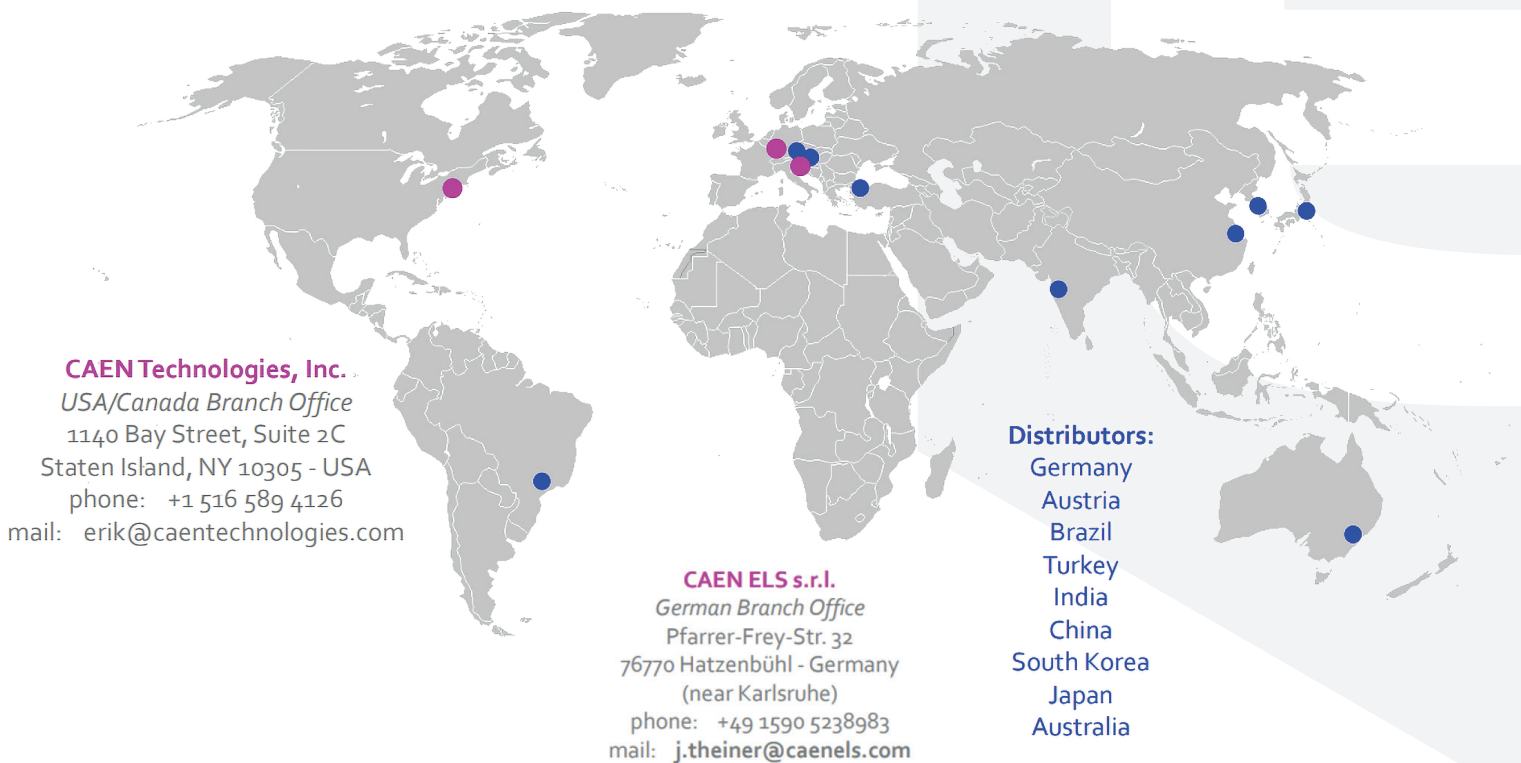

CAEN Technologies, Inc.

USA/Canada Branch Office
1140 Bay Street, Suite 2C
Staten Island, NY 10305 - USA
phone: +1 516 589 4126
mail: erik@caentechnologies.com

CAEN ELS s.r.l.

German Branch Office
Pfarrer-Frey-Str. 32
76770 Hatzenbühl - Germany
(near Karlsruhe)
phone: +49 1590 5238983
mail: j.theiner@caenels.com

Distributors:

Germany
Austria
Brazil
Turkey
India
China
South Korea
Japan
Australia
...



Copyright © ELS Instruments srl - 2026

All rights reserved. Information in this publication supersedes all previous versions.
Specifications subject to change without notice.

Rev. 1.2 - Printed in May 2026