

FAST-Bi-K5

1.5-kW Bipolar Bidirectional and Regenerative Digital Power Supply Series



User Manual



All Rights Reserved
© CAEN ELS S.r.l.
Rev. 1 – March 2026



This product is **CE** & compliant.
UK
CA



CAEN ELS s.r.l.

Karl Ludwig Von Bruck, 32 – 34144 Trieste (TS)
Italy

Mail: info@caenels.com

Web: www.caenels.com





EU DECLARATION OF CONFORMITY

Product:

Laboratory Power Supply
CAEN ELS s.r.l. – FAST-Bi-1K5 series
FAST-Bi-1K5 20-100
FAST-Bi-1K5 30-50
FAST-Bi-1K5 50-40
FAST-Bi-1K5 100-20
FAST-Bi-1K5 150-10

Manufacturer:

CAEN ELS s.r.l.
Karl Ludwig Von Bruck, 32
34144 Trieste (TS)
Italy

This declaration of conformity is issued under the sole responsibility of the manufacturer.

Object of the Declaration:

Laboratory Power Supply
Brand: CAEN ELS s.r.l.
Model Family: FAST-Bi-1K5



The object of the declaration described above is in conformity with the relevant Union harmonisation legislation:

2014/30/EU relating to electromagnetic compatibility

2014/35/EU relating to the making available on the market of electrical equipment designed for use within certain voltage limits

References to the relevant harmonised standards used or references to the other technical specifications in relation to which conformity is declared:

EN 61326-1:2013 Electrical equipment for measurement, control and laboratory use - EMC requirements.

EN 61010-1:2010 Safety requirements for electrical equipment for measurement, control, and laboratory use -- Part 1: General requirements.

Signed for and on behalf of: CAEN ELS s.r.l.

Trieste – March 4th, 2026

Enrico Braidotti, CEO



Models – Options – Accessories – Custom Models

This manual covers the following standard Power Supplies models:

Model	Ordering code
FAST-Bi-1K5 20-100	FB1K5020100X
FAST-Bi-1K5 30-50	FB1K5030050X
FAST-Bi-1K5 50-40	FB1K5050040X
FAST-Bi-1K5 100-20	FB1K5100020X
FAST-Bi-1K5 150-10	FB1K5150010X

This manual covers the following optional units:

- **FB1K5OPT0001 – Analog Control, Auxiliary ADC, Trigger Input and K-type thermocouple add-on**
- **FB1K5OPT0002 – High-Bandwidth**

This manual covers the following accessories:

- **CABL-PSS0041 - FAST-Bi-1K5 BUSBAR KIT - 2-Channel Parallel Busbar and protection kit**
- **CABL-PSS0042 - FAST-Bi-1K5 BUSBAR KIT - 3-Channel Parallel Busbar and protection kit**
- **CABL-PSS0043 - FAST-Bi-1K5 BUSBAR KIT - 4-Channel Parallel Busbar and protection kit**

For technical assistance please refer to the following contact:

CAEN ELS s.r.l.
 Karl Ludwig Von Bruck, 32
 34144 Trieste (TS) – Italy

Phone: +39 040 883 0028
 Fax: N/A
 e-mail: support@caenels.com

Table Of Contents

1. INTRODUCTION.....	12
1.1 FAST-BI-1K5 OVERVIEW	12
1.2 FAST-BI-1K5 AT A GLANCE.....	14
1.3 MODES OF OPERATION.....	16
1.3.1 Regulation Mode.....	16
1.3.2 Control Mode.....	16
1.3.3 Update Mode.....	17
2. INSTALLATION.....	18
2.1 PREPARATION FOR USE.....	18
2.2 INITIAL INSPECTION	18
2.3 MOUNTING.....	19
2.3.1 Rack Mounting.....	19
2.3.2 Desktop use.....	19
2.4 AC INPUT POWER CONNECTION	20
2.4.1 AC Source requirement.....	22
2.4.2 AC Input Cable	22
2.5 LOAD CONNECTION.....	23
2.5.1 Wire selection.....	23
2.6 RECOMMENDED LENGTH FOR CABLES.....	24
2.7 GROUNDING OUTPUTS	25
2.8 FUNCTIONAL GROUND.....	25
2.9 FIRMWARE UPDADE.....	26
2.9.1 Firmware upgrade from the GUI.....	27
3. FRONT/REAR PANEL CONTROLS AND CONNECTORS	28
3.1 EXTERNAL INTERLOCKS AND OUTPUT STATUS.....	28
3.2 REMOTE SENSING	30
3.3 PERSISTENT SWITCH	32
3.3.1 PCS safe operating area	33
3.4 OPTIONAL UNIT FB1K5OPT0001	34
3.4.1 Trigger Input (TRG. IN).....	34
3.4.2 Analog Control Input (AN. IN)	35
3.4.1 Configurable AUX Input (AUX. IN).....	35
3.4.2 K-type thermocouple connector.....	36
3.5 OUTPUT CONNECTORS.....	37
3.5.1 High-Current (HC) Models.....	37
3.5.2 High-Voltage (HV) Models	38
3.6 FRONT PANEL INDICATORS	39
3.7 INTERNAL PROTECTIONS.....	40
3.7.1 Temperature Fault	41
3.7.2 DC-Link Fault.....	41
3.7.3 Input OVERCurrent – OVC.....	41
3.7.4 Earth Leakage.....	42
3.7.5 Earth Fuse.....	42
3.7.6 Regulation Fault	42

3.7.7	DCCT Error.....	43
3.7.8	OverPower - OVP	43
3.7.9	Crow-Bar	44
3.7.9.1	Crow-Bar Enable: rear panel connector.....	44
3.7.10	Quench	45
3.7.11	Output Overcurrent/Overvoltage.....	46
3.7.12	Interlock #1 #2 #3 #4	46
3.7.1	Parallel Link Fault.....	47
3.7.2	Parallel Configuration Error.....	47
3.7.3	Fans Error	47
4.	ADVANCED FUNCTIONS	48
4.1	WAVEFORM	48
4.2	PARALLEL OPERATION.....	49
4.3	PARALLEL BUSBAR KIT	52
4.3.1	Parallel Busbar Kit mounting instructions	52
5.	MECHANICAL DIMENSIONS.....	55
6.	TECHNICAL SPECIFICATIONS	57

Document Revisions

Revision	Date	Comment
0.0	September 15 th , 2023	Preliminary Release
0.1	December 19 th , 2023	Text revised, removed all references to TCP-IP commands.
0.2	December 20 th , 2023	Major text revision.
0.3	December 21 th , 2023	Major text revision.
0.4	January 4 th , 2024	Major text revision.
0.5	January 8 th , 2024	Major text revision. Index reorganization.
0.6	February 1 st , 2024	Minor text revision. Compatible with fw version 1.0.02.
0.7	February 8 th , 2024	Moved the Local Control chapter to the Quick Start Guide. Minor text revision in the Modes of Operation. Updated description of front panel indicators.
0.8	February 20 th , 2024	Added parallel advanced feature (section 4.2). Internal memory ID rearranged. Compatible with fw version 1.0.04.
0.9	March 13 th , 2024	Updated technical specs. Update AC input cable section. Compatible with fw version 1.0.05.
0.10	May 15 th , 2024	Added tech specs for HV models. Compatible with fw version 1.0.08.
0.11	August 5 th , 2024	Added G99 caution note. Changed headquarter address.
0.12	January 27 th , 2025	Updated picture of the product presentation and declaration of conformity. Updated Parallel Operation (section 4.2)
0.13	March 7 th , 2025	Changed “Setpoint mode” to “Update mode” (section 1.3.3)
0.14	October 1 st , 2025	Added supported specifications for K-Type Thermocouple (section 3.4.2) Updated technical specs (section 6)
0.15	January 21 st , 2026	Corrected max output power for the 20–100 model (section 6)
0.16	March 4 th , 2026	Added Parallel Busbar and Protection kit (section 4.3); updated EU Declaration of Conformity
1	March 30 th , 2026	Changed the Earth Fuse picture (section 3.7.5)







Safety information

The following table shows the general environmental requirements for a correct operation of instruments referred in this User’s Manual:

Environmental Conditions	Requirements
Environment	Indore use
Operating Temperature	0°C to 50°C
Operating Humidity	20% to 80% RH (non-condensing)
Altitude	Up to 2000 m
Pollution degree	2
Overtoltage Category	II
Storage Temperature	-10°C to 60°C
Storage Humidity	5% to 90% RH (non-condensing)

The following symbols are used within this manual or are reported in the box and along this manual:

-  **CAUTION Risk of Electrical Shock**
-  Caution: Documentation must be consulted in all cases where this symbol is marked
-  Indicates ground terminal
-  Protective Ground Conductor Terminal
- **0** Off (Power)
- **I** On (Power)

WARNING

- The WARNING sign denotes a hazard. An attention to a procedure is called. Not following the procedure correctly could result in personal injury. A WARNING sign should not be skipped and all indicated conditions must be fully understood and met.

CAUTION

- The CAUTION sign denotes a hazard. An attention to a procedure is called. Not following procedure correctly could result in damage to the equipment. Do not proceed beyond a CAUTION sign until all indicated conditions are fully understood and met.

CAEN ELS S.r.l. will repair or replace any product within the guarantee period if the Guarantor declares that the product is defective due to workmanship or materials and has not been caused by mishandling, negligence on behalf of the User, accident or any abnormal conditions or operations.

Please read carefully the manual before operating any part of the instrument

WARNING

**Do NOT open the BOX TOP
COVER**

CAUTION

Customer shall provide the use of a G99 contactor to cover the ERE G99 requirements for the connection of generation equipment in parallel with public distribution networks

CAEN ELS S.r.l. declines all responsibility for damages or injuries caused by an improper use of the Modules due to negligence on behalf of the User. It is strongly recommended to read thoroughly this User's Manual before any kind of operation.

CAEN ELS S.r.l. reserves the right to change partially or entirely the contents of this Manual at any time and without giving any notice.

Disposal of the Product

The product must never be dumped in the Municipal Waste. Please check your local regulations for disposal of electronics products.



WARNING

- Do not use this product in any manner not specified by the manufacturer. The protective features of this product may be impaired if it is used in a manner not specified in this manual.
- Do not use the device if it is damaged. Before you use the device, inspect the instrument for possible cracks or breaks before each use.
- Do not operate the device around explosives gas, vapor or dust.
- Always use the device with the cables if provided.
- Turn off the device before establishing any connection.
- Do not operate the device with the cover removed or loosened.
- Do not install substitute parts or perform any unauthorized modification to the product.
- Return the product to the manufacturer for service and repair to ensure that safety features are maintained.
- This is a Class A product. On a domestic environment, this product may cause radio interference in which case user may be required to take adequate measures.

1. Introduction

This chapter describes the general characteristics and main features of the FAST-Bi-1K5 bipolar bidirectional and regenerative Power Supply (PS) series.

1.1 FAST-Bi-1K5 Overview

High performances, extreme stability, easiness of configuration as well as bidirectional and regenerative characteristics are the key features of the FAST-Bi-1K5 power supply series.

The FAST-Bi-1K5 is an independent current- or voltage-controlled digital bipolar, bidirectional and regenerative power supply module. Different models having different current and voltage output ratings are commercially available, see Table 1.1; the table reports also the classification between High-Current (HC) and High-Voltage (HV) models.

Model Name	Current	Voltage	HC vs HV
FAST-Bi-1K5 20-100	± 20 A	± 100 V	HV
FAST-Bi-1K5 30-50	± 30 A	± 50 V	HV
FAST-Bi-1K5 50-40	± 50 A	± 40 V	HC
FAST-Bi-1K5 100-20	± 100 A	± 20 V	HC
FAST-Bi-1K5 150-10	± 150 A	± 10 V	HC

Table 1.1: FAST-Bi-1K5 standard models.

The FAST-Bi-1K5 module is compact and fits in a single 19-inch 2U standard crate. The PS (Power Supply) implements a completely digital control loop with a Pulse Width Modulation (PWM) generation technique that allows adapting the system to any load condition.

The control board houses a dedicated FPGA with integrated dual-core ARM CPU. The loop regulation task is performed directly by the FPGA logic, in order to have high performance and deterministic loop control. On the ARM CPU it is installed

an embedded Linux OS, that supervises all processes as communication, diagnostics and local interface handling.

Remote communication is guaranteed by means of an Ethernet 10/100/1000 Mbit autosensing socket, present on the front panel of the PS. The power supply can be also monitored and controlled via a navigation switch and a graphic high resolution color display featuring user-friendly menus.

In addition to the standard Ethernet interface, it is possible to communicate with the PS using the SFP-ports on the front panel. This interface allows the communication using a proprietary packet structure with an update rate up to 100 kHz. These ports are directly connected to the FPGA logic, so that the packet is elaborated directly by the hardware logic.

This approach bypasses the software stratification that manages the packet. The computational time is shorter and deterministic, leading to a high update rate of the setpoint, and gaining flexibility and excellent rates for the digital control of the power supply.

1.2 FAST-Bi-1K5 at a glance

The FAST-Bi-1K5 system is composed by a single 19-inch 2U crate. **Figure 1** shows the PS front panel.

Figure 2 and **Figure 3** show the rear panel for the high-current and high-voltage models, respectively.



Figure 1: FAST-Bi-1K5 front view.

The front side of the FAST-Bi-1K5 (**Figure 1**) is equipped with:

1. a power switch;
2. a colour graphic display;
3. a navigation switch for the PS local control;
4. three communication sockets (two SFPs and one Ethernet port), 4 status LEDs and one USB device connector.

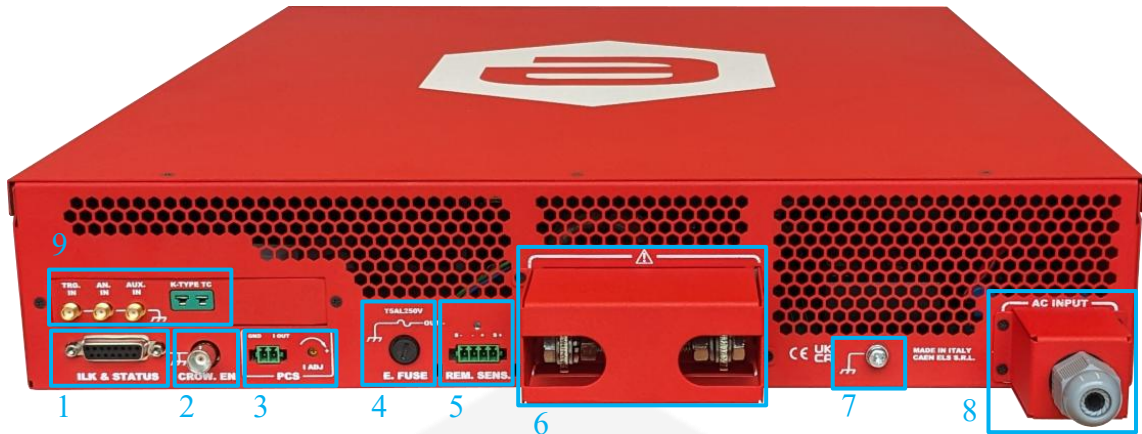

Figure 2: FAST-Bi-1K5 rear view for the 150 A, 100 A and 50 A models (“HC” models). N.B. the PS mounts the FB1K5OPT001 option, including the Trigger, Analog Control and Auxiliary inputs, as well as a K-type connector for thermocouples.



Figure 3: FAST-Bi-1K5 rear view for the 30 A and 20 A models (“HV” models). N.B. the PS mounts the FB1K5OPT001 option, including the Trigger, Analog Control and Auxiliary inputs, as well as a K-type connector for thermocouples.

The rear side of the PS (**Figure 2** and **Figure 3** for HC and HV models, respectively) is equipped with:

1. D-Sub 15 Female Pin I/O connector for external interlock inputs and status output;
2. BNC connector to enable the crowbar (future uses for parallel operation);
3. a persistent switch output connector (2-pins connector);
4. the earth leakage fuse;
5. the remote sensing connector (4-pins connector);
6. the output terminals;
7. an earth reference;
8. the AC power line input;
9. three SMA jack connectors (Trigger, Analog Control, Auxiliary inputs) and K-type connector for external thermocouple for PSs mounting the FB1K5OPT001 option.

1.3 Modes of Operation

The FAST-Bi-1K5 system has multiple features and multiple configurations that allow using the PS for a very widespread topology of applications.

A brief summary of the basic configurations that the PS is able to handle are hereafter presented.

1.3.1 Regulation Mode

The FAST-Bi-1K5 can be used as current-controlled or voltage-controlled bipolar PSs. The regulation types are:

- **C.C.** mode: it is the Constant Current regulation mode. The power supply regulates the output current set by the user;
- **C.V.** mode: it is the Constant Voltage regulation mode. The power supply regulates the output voltage set by the user.

In C.V. mode it is possible to use the *remote sensing* terminals that allow regulating the output voltage directly on the load, thus compensating the voltage drops on the output cables. The FAST-Bi-1K5 is capable of compensating a voltage drop up to 0.5 V.

1.3.2 Control Mode

The FAST-Bi-1K5 can be controlled in two different ways:

- **LOCAL** control: the PS can be controlled via the front panel color display and the navigation switch. When the PS is set in LOCAL mode, all the setting commands are denied. However, it is possible to perform readings and monitor the status of the PS from the remote interface;
- **REMOTE** control: the PS is controlled via the TCP-IP Ethernet interface. The setting and control of the PS can be performed exclusively via this interface, while monitoring is possible from the local display as well;

A detailed description of the LOCAL and REMOTE controls can be found in the “Quick Start Guide”.

1.3.3 Update Mode

The current or voltage setting of the PS can be performed in four different update modes:

- **NORMAL**: the update of the set-point (current or voltage) is performed as soon as a new set-point is received via remote control, local control or fast interface;
- **WAVEFORM**: the update of the set-point is performed on a specific timing (defined as a “waveform” attribute, more information on the *Waveform* section) and it is done internally;
- **SFP**: this interface allows controlling the PS via a proprietary protocol over the SFP/SFP+ interfaces (optical or electrical) in case of very fast applications. Update rates up to 100 kHz are reachable using this communication channel.
- **ANALOG INPUT**: the PS is controlled by an external signal that is fed to the rear BNC connector. The PS acts as a C.C. or C.V. generator depending on the Regulation Mode. Please note that this update mode is possible only on PSs having installed the analog input SMA connector (FB1K5OPT0001 ordering option).

Please note that the ANALOG INPUT update mode is available only with the FB1K5OPT0001 option at the time of purchase.

More information about the different update modes of operation can be found in the “Quick Start Guide”.

2. Installation

This chapter contains instructions for initial inspection and preparation for use.

2.1 Preparation for use

In order to be operational, the PS must be connected to an appropriate AC source. The AC source voltage should be within the PS specification. Do not apply power before reading sections 2.2 and 2.6.

The installation procedure is described in **Table 2.1**.

Step	Checklist	Description
1	Initial inspection	Physical inspection of PS
2	Mounting	Installing the PS, ensuring proper ventilation
3	AC Input Power Connection	Connect the PS to the AC source
5	Load connection	Wire size selection, Remote Sensing
4	First switch-on	Switch-on checkout procedure

Table 2.1: Installation checklist

2.2 Initial inspection

Prior to shipment, the PS was inspected and found free either of mechanical or electrical defects. Upon unpacking of the PS, inspect is suggested for any damage which may have occurred in transit.

The inspection should confirm that there is no-exterior damage to the PS (e.g. broken switch or connectors) and all panels and display are not scratched or cracked. Keep all packaging material until the inspection has been completed. If a damage has been detected, compile the RMA form available on the CAEN ELS web site.

2.3 Mounting

The FAST-Bi-1K5 module can be used either as a rack-mount device (since the PS form factor is designed to be installed in a standard 2U 19-inch cabinet) or as a desktop unit.

CAUTION

This PS is fan cooled, the air intake is at the front panel and the exhaust is at the rear panel. Allow cooling air to reach the front panel ventilation inlets, ensuring at least 10 cm of unrestricted air space at the front and the rear of the unit.

2.3.1 Rack Mounting

The FAST-Bi-1K5 series is designed to fit in a standard 19" equipment rack.

CAUTION

Use a support bar to provide adequate support for the PS.

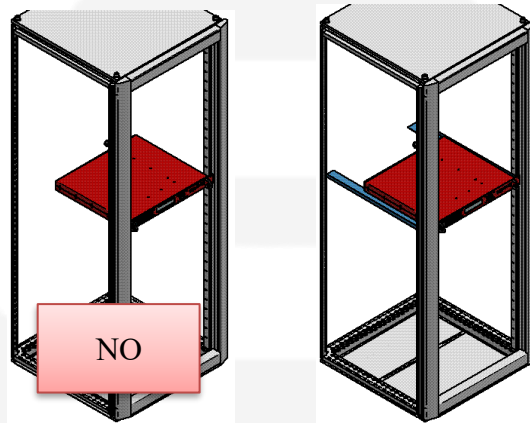

2.3.2 Desktop use

The FAST-Bi-1K series can be used as desktop unit as well. All the precautions must be observed to avoid touching the output connectors.

WARNING

Users shall protect output contacts either by placing the FAST-Bi-1K5 inside a closed rack or by restricting the access to the back side of the PS.

2.4 AC Input Power Connection

WARNING

There is a potential electrical shock hazard when using a PS without protection. Do not connect PS to AC supply line without input protection properly assembled.

CAUTION

Customer shall provide the use of a G99 contactor to cover the ERE G99 requirements for the connection of generation equipment in parallel with public distribution networks.

CAUTION

Connection of this PS to an AC mains should be made by an electrician or other qualified personnel.

CAUTION

There is a potential shock hazard if the PS chassis (with cover in place) is not connected to an electrical safety ground via the safety ground terminal in the AC input connector.

CAUTION

AC Input Wires No Conductor Pretreatment: all kinds of copper conductors can be clamped without pretreatment (Solid, Flexible, with ferrule, with/without plastic sleeve). It is forbidden to solder the conductors. The solder tin yields and fractures under high pressure. The result is an increased contact resistance and an excessive temperature rise. In addition, corrosion caused by pickling or fluxes has been observed on soldered conductor ends. Notch fractures at the transition point from the rigid to the flexible conductor area are also possible.

CAUTION

The PS ON/OFF switch is not the main "disconnect device" and does not completely disconnect all the circuits from the AC mains. An appropriately rated "disconnect device" such as circuit breaker, industrial plug complying with IEC 60309 or with a comparable national standard, etc., shall be

provided in the final installation. The "disconnect device" shall disconnect all supply lines simultaneously. The "disconnect device" must be easily accessible.

The connection of this PS to an AC power source should be made by an electrician or other qualified personnel. The PS shall be connected to the AC source via protective device (circuit breaker, fuses, etc.) rated 20 A max.

WARNING

The use of a Residual Current Device (RCD) shall be avoided because the internal PFC can inject residual current when the PS is switched OFF.

The AC line input connector on the rear panel is a 7.62 mm terminal block plug from Würth-Elektronik (P/N: 691340400003) able of housing cables with 0.2-3.3 mm² of diameter (tightening torque required 0.56 [N·m]).

AC input cord is not provided with the PS. Refer to section 2.4.2 for recommended cables and to Figure 4, Figure 5, Figure 6 and Figure 7 for a correct and safe installation of the AC input cable.

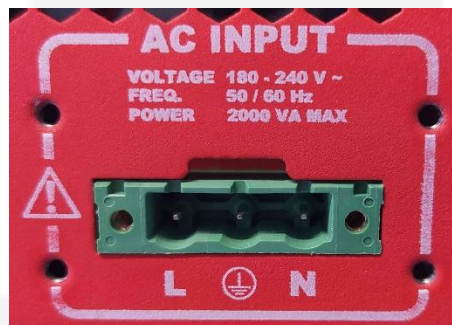

Figure 4: AC Power Line input without terminal block.



Figure 5: AC Power Line input with terminal block.

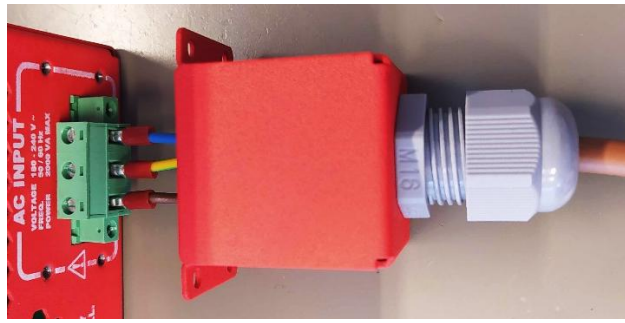

Figure 6: AC Power Line input with connector and cover unmounted.



Figure 7: AC Power Line input with cover mounted.

2.4.1 AC Source requirement

The FAST-Bi-1K5 power supplies are designed for an AC input ranging from 180 V to 264 V and input frequency ranging of 47 Hz or 63 Hz. Installation Category shall be **CAT II**, so maximum impulse voltage on the network mains must be below 2500 V.

2.4.2 AC Input Cable

AC input cables are not provided with the PS. **The AC input cables must satisfy the characteristics reported in Table 2.2.**

AC Input Cable

- 3x 1.5 mm² (2 m maximum length) or 3x 2.5 mm² (length > 2 m);
- 2 wire and a safety ground, stranded copper, 300 V, 105 °C minimum, rated for 20 A;
- Outer diameter: 6-13 mm.

Table 2.2: AC input cables characteristics.

2.5 Load connection

WARNING

Turn off the AC input power before making or changing any rear panel connection. Ensure that all connections are securely tightened before applying power. There is a potential shock hazard when using a PS with a rated output greater than 50 V

2.5.1 Wire selection

More factors must be considered for the selection of the wires:

- Current carrying capacity (i.e. cross section area)
- Maximum wire length
- Insulation voltage

Wire cross section and length

Wire size should be selected to enable voltage drop per lead to be less than 1 V at the maximum PS current to prevent excessive output power consumption. Suggested wire sizes are listed in the following table:

Wire Cross Section Area [mm ²]	Resistivity [Ω/km]	Maximum Cable length in meters to limit voltage drop to be less than 2 V (1 V per lead)				
		20 A	30 A	50 A	100 A	150 A
2.5	8.00	6	-	-	-	-
4	5.00	10	6.5	-	-	-
6	3.33	15	10	-	-	-
10	2.00	25	16.5	10	-	-
16	1.30	40	26.5	16	8	-
25	0.80	62.5	41.5	25	12.5	-
35	0.57	87.5	58	35	17.5	11.5

Table 2.3: Wire selection

If Table 2.3 values are used the maximum voltage to the load will be limited to:

$$OV_{\text{nom}} + CV_{\text{max}} - DV_{\text{cable}}$$

where OV_{nom} is the PS nominal output voltage, CV_{max} is the maximum compensation voltage if remote sensing is used and DV_{cable} is the cable drop voltage.

Maximum compensation Voltage for all models is 0.5 V

For instance, the FAST-Bi-1K5 100-20 that have a nominal output voltage of 20 V connected to a load at 8 meter of distance using 2x16 mm² cables, can drive at maximum $20 + 0.5 - 2 = 18.5$ V at 100 A on the load.

FAST-Bi-1K5 HC model (with nominal output voltage ≤ 50 V)

For those models the load has to be connected directly to the Busbars using lug terminals for M8 screws. Always use spring washer and plane washer for a reliable connection. Tightening torque shall be about 15 – 25 N·m.

More details on the output connector are reported in section 3.5.1.

FAST-Bi-1K5 HV models (with nominal output voltage > 50 V)

FAST-Bi-1K5 models that have output voltage > 50 V shall be connected to the load with a double insulation cable which have voltage rating adequate to the maximum output voltage.

More details on the output connector are reported in section 3.5.2.

WARNING

Hazardous voltage exists at the outputs and the load connections. To protect personnel against accidental contact with hazardous voltage, ensure that the load and its connections have no accessible live parts. Ensure that the load wiring insulation ratings is greater than or equal to the maximum output voltage of the PS.

2.6 Recommended Length for Cables

The recommended length for cables is listed in **Table 2.4**.

Connector	Length
DC Ooutput	< 30 m
AC Input	< 30 m
Interlock & Status (ILK & STATUS)	< 3 m
Crowbar Enable (CROW. EN)	< 3 m
Persistent Current Switch (PCS)	< 3 m



Connector	Length
Remote Sensing (REM. SENS.)	< 3 m
*Trigger Input (TRG. IN)	< 3 m
*Analog Input (AN. IN)	< 3 m
*Auxiliary Input (AUX. IN)	< 3 m
*Thermocouple (K-TYPE TC)	< 3 m

Table 2.4: Recommended length for the cables. *These connectors are available only with the ordering option FB1K5OPT0001.

2.7 Grounding Outputs

By factory default configuration the FAST-Bi-1K5 minus terminal is grounded to the Protective Ground (i.e. chassis, Mains-Earth terminal and all metallic parts composing the box) through a fuse, Earth Fuse, which is accessible from the rear panel. Under this configuration, the Output Terminals are not floating and cannot be connected to Protective Ground.

If one of the output terminals is accidentally conducting to the Protective Ground a fault will be triggered resulting in PS output disable. Refer to Earth Fuse (section 3.7.5) and Earth Leakage (section 3.7.6).

To allow output floating operation, it is sufficient to remove the Earth Fuse from the fuse-holder and set the PS for Floating operation (see the *“Quick Start Guide”* for setting the PS in floating mode).

When the PS is configured to operate in floating mode either the positive or negative output terminals can be grounded. Always use two wires to connect the load to the PS regardless of how the system is grounded.

WARNING

Models shall not float outputs more than $\pm 200\text{VDC}$ above/below chassis ground.

2.8 Functional Ground

Figure 8 shows the Functional Ground connection. **The maximum penetration depth (“L” in Figure 9) of th ground mounting screw is 8 mm.**



Figure 8: Functional Ground Connection.

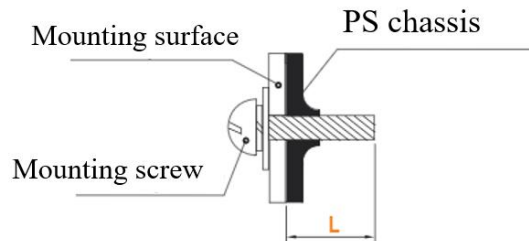

Figure 9: Ground screw picture.

2.9 Firmware Update

There are two ways to update the PS firmware:

- from the GUI;
- from the *Device Manager* (refer to the *Device Manager User's Manual*).

The last stable firmware can be downloaded from CAEN ELS website from the correspondent product page in the “*Software/Firmware*” section, as reported in Figure 10.

WARNING

**Install only firmware files with .updt extension
downloaded from the CAEN ELS website
(www.caenels.com)**

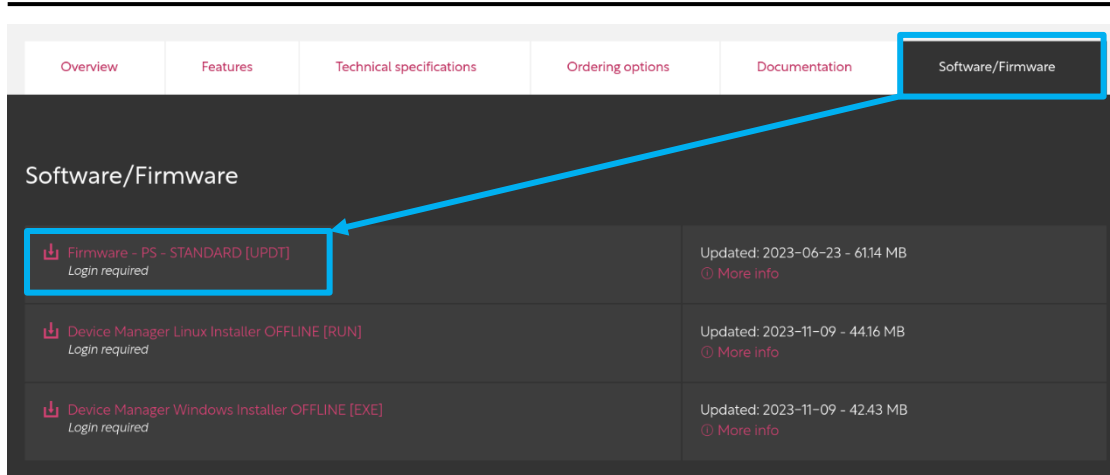

Figure 10: Firmware download page.

2.9.1 Firmware upgrade from the GUI

Type the PS IP address in the web browser address bar to access the GUI and go to the Update page from the right panel of the GUI, as reported in Figure 11.

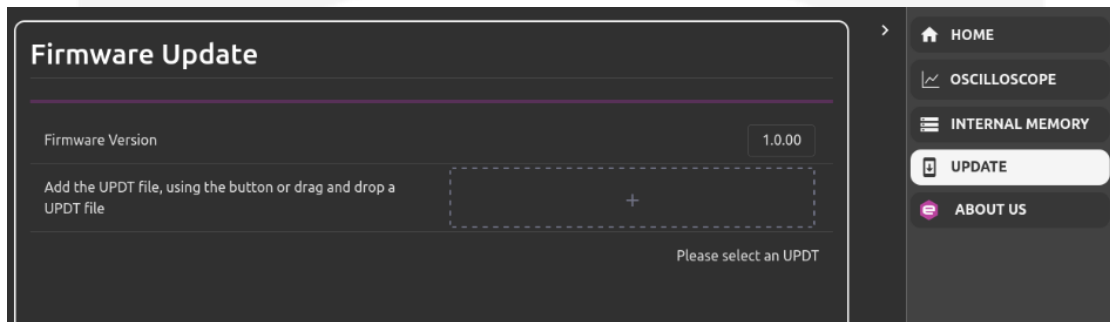

Figure 11: Firmware Update page.

Load the firmware file, previously downloaded from the CAEN ELS website, and click on *Install* button, as shown in Figure 12.

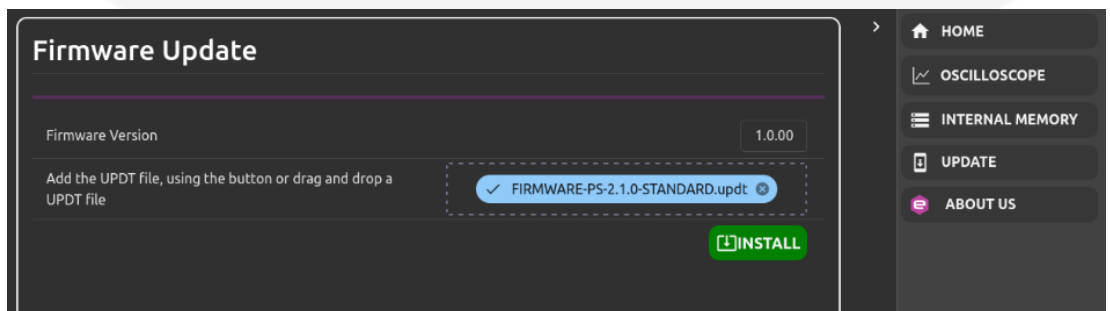

Figure 12: Upload firmware file.

The firmware update procedure can take up to 5 minutes to complete.

At the end of the update procedure the PS is automatically rebooted and once the reboot is completed the webpage should refresh automatically. If not, refresh the webpage manually.

3. Front/Rear Panel Controls and Connectors

3.1 External Interlocks and Output Status

The system is provided with four external interlock inputs that can be easily configured using the GUI or directly using the PS commands (refer to the “*Commands Reference Manual*” for more information). Two output status signals, a Magnetic Relay and Solid-State Relay, provide the output status of the power module. There are two kinds of Magnetic Relay:

- Normally Open (NO): when the PS output is OFF the Magnetic Relay is in open-circuit, viceversa when the PS output is ON the Magnetic Relay is in short-circuit.
- Normally Closed (NC): when the PS output is OFF the Magnetic Relay is in short-circuit, viceversa when the PS output is ON the Magnetic Relay is in open-circuit.

The Solid-State Relay instead behaves like a Normally Open Relay.

External Interlocks and Output Status signals are available on a D-Sub 15 Pin Male type on the rear panel of the FAST-Bi-1K5, **Figure 13**.



Figure 13: I/O Connector

The list of the pins and their functionality is listed in **Table 3.1**.

Pin Number	Pin Function
1	Ext. Int #1 -
9	Ext. Int #1 +
2	Ext. Int #2 -
10	Ext. Int #2 +
3	Ext. Int #3 -
11	Ext. Int #3 +
4	Ext. Int #4 -
12	Ext. Int #4 +
5	Not Connected
13	Mag. Relay Central Node
6	Not Connected
14	Mag. Relay - NC
7	Solid State Relay 1
15	Mag. Relay - NO
8	Solid State Relay 2

Table 3.1: Corresponding Pin Function on Rear DB15 connector.

The absolute maximum current that can be sunk by the relays are shown in the following table:

Relay	Pins	Max Current	Max Voltage
Magnetic	#13-14-15	1 A	48 V
Solid state	# 7-8	400 mA	48 V

Table 3.2: Ratings of relays

WARNING

Magnetic Relay Contact and Solid State Relay Terminals (Terminal #1 & #2) shall not float more than ± 60 VDC above/below chassis ground.
Interlocks input and return pins shall not float more than ± 60 VDC above/below chassis ground.

CAUTION

Voltage between relay pins shall never exceed ± 48 V. Maximum current rating for the Magnetic Relay is 1 A; current through pins #13 and #14 or pins #13 and #15 shall never exceed 1 A. Maximum current rating for the Solid State Relay is 400 mA; current through pins #7 and #8 shall never exceed 400 mA. Do not apply voltage between any input interlock and its corresponding return.

The interlock pins are galvanically isolated from ground and outputs terminal, nevertheless the absolute maximum voltage, referred to ground, that pins can continuously sustain is 48V. The four interlocks inputs have their own return connection. The interlock is hardware-activated when the input pin and its corresponding return pin are shorted.

For more details on external interlock and status signals configuration refer to the “Commands Reference Manual”.

3.2 Remote Sensing

WARNING

There is a potential shock hazard at the sense point when using PS with rated output voltage greater than 50 V. Ensure that the connections at the load end are shielded to prevent accidental contact with hazardous voltages.

CAUTION

A short from V_{SENS+} or V_{OUT+} to V_{SENS-} or V_{OUT-} will cause damage to the PS. Reverse the sense wire might cause damage to the PS in local and remote sensing. Do not connect +S to – or –S to +.

The Remote Sensing Connector (placed on the rear panel) is reported in **Figure 14** (left picture) and its pinout is reported in **Table 3.3**. The PS is shipped with the remote sensing terminal block (see **Figure 14** right picture) from Würth-Elektronik (P/N: 691304330004).

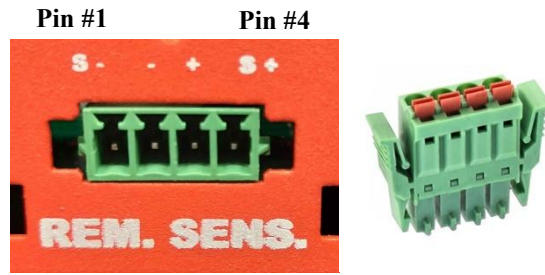

Figure 14: Remote Sensing connector on PS rear panel (left picture). Remote Sensing terminal block (right picture)

Description	Pin	Name
$V_{SENSE -}$	#1	S-
$V_{OUT -}$	#2	-
$V_{OUT +}$	#3	+
$V_{SENSE +}$	#4	S+

Table 3.3: Remote sensing pinout.

By using the two “sensing” pins (S+ and S-, pins 4 and 1, respectively), it is possible to sense the output voltage directly on the load, thus neglecting eventual voltage drops on the output cables up to 0.5 V.

It is strongly recommended to use twisted cables when using the remote sensing feature to limit the pick-up noise.

The FAST-Bi-1K5 is shipped with a mating connector for the remote sensing that short-circuits the S+ and + pins and the S- and - pins, respectively (see **Figure 15**). This configuration performs the remote sensing directly at the output connector of the PS. When using the remote sensing feature, leave pins #2 (+) and #3 (-) disconnected.



Figure 15: Factory mating Remote Sensing connector.

Follow the instructions below to configure the PS for remote sensing:

1. Ensure that Mains switch is on Off position “O”
2. Remove factory jumpers between +S to + and -S to -.

3. Using a twisted pair or shielded cable (suggested wire size is 0.3 or 0.5 mm²) connect the +S terminal to the positive output terminal and the –S to the negative output terminal as illustrated in **Figure 17**.
4. **For FAST-Bi-1K5 with output voltage rating > 50 V**, fix the Safety cover to the rear panel using the M3x10 mm screw, **Figure 16**.



Figure 16: Remote Sensing Cover

In order to perform remote sensing at different points – e.g. the load terminals – it would be necessary to connect Pin #1 and Pin #4 as in **Figure 17**:

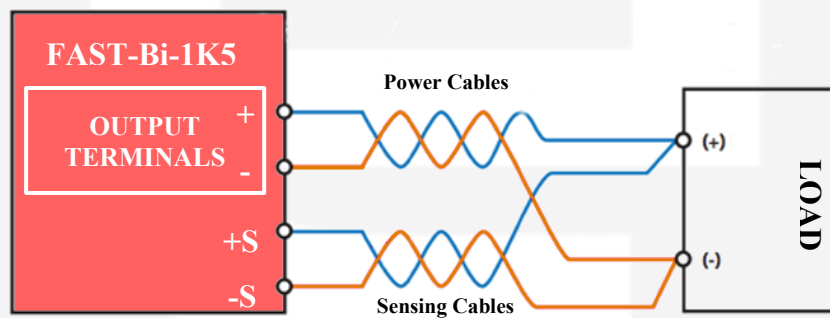

Figure 17: Example of Remote Sensing

3.3 Persistent Switch

The FAST-Bi-1K5 is equipped with a Persistent Current Switch (PCS) output connector (see **Figure 18**) capable of sourcing up to 240 mA. The PS is shipped with the terminal block plug from Wurth-Elektronik (P/N: 691304330002). The PCS output current can be adjusted by variable resistor indicated as “I ADJ” in **Figure 18**. The PS is shipped with a PCS output current configured at 50 mA.

The PCS output can be controlled from the GUI or with specific PS commands (refer to the “*Commands Reference Manual*” for more information).



Figure 18: PCS on the PS rear panel (left). PCS terminal block plug (right).

CAUTION

The Persistent Switch Output is not limited by any resistor thus care must be taken in select the correct current corresponding to the PCS load resistor. See section 3.3.1 for more details on load resistor.

CAUTION

The Persistent Switch Output is not floating but it is referred to the Chassis Earth. Connect only to floating Persistent Switch.

3.3.1 PCS safe operating area

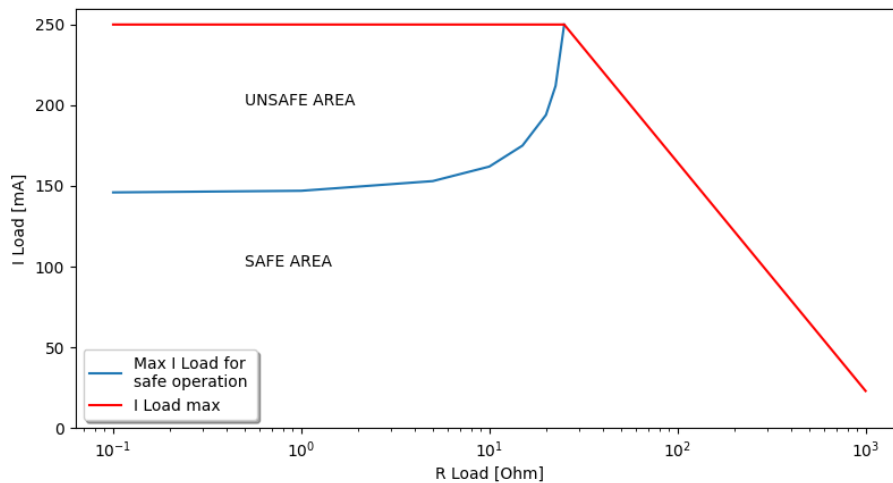

Figure 19: PCS load resistor-current operating graph.

The operating area of the PCS output is reported in Figure 19. The upper region between the red curve (maximum PCS output current) and the blue curve (maximum PCS output current safely sustained by internal electronics) is the unsafe operating area. The lower region between the blue curve and red curve is considered safe.

The maximum safe current sourced by the PCS output for load resistors smaller than 1 Ω is 150 mA. For load resistor larger than 25 Ω the maximum PCS output current

is *roughly* obtained by Ohm's law on the load resistor (24V divided by the load resistor value).

3.4 Optional Unit FB1K5OPT0001

The additional option FB1K5OPT0001 for the FAST-Bi-1K5 includes input connectors (SDA jack) for an external Trigger signal (TRG. IN), for an Analog control (AN. IN) and for an additional conversion (ADC) auxiliary channel (AUX. IN), see **Figure 20**. An input connector for K-type thermocouple is also present.

CAUTION

The SMA connectors are not floating but they are referred to the Chassis Earth.



Figure 20: SDA jack input connectors and K-type for thermocouple.

A brief description of these features and their functionalities is presented hereafter.

3.4.1 Trigger Input (TRG. IN)

The Trigger Input (TRG. IN) accepts TTL (5V) and LVTTTL (3.3V) compatible signals and should be driven by a low-impedance source.

The logic levels are subject to a hysteresis that allows for these recognized values that guarantee correct operation of the trigger as listed in **Table 3.4**.

Logic Level	Value
Low-to-HIGH	> 2.0 V
High-to-LOW	< 0.8 V

Table 3.4: Trigger Logic Levels for trigger input.

CAUTION

The absolute maximum rating for the Trigger Input signal is of **5.5 V** (a higher voltage level applied to this input can seriously damage the device).

3.4.2 Analog Control Input (AN. IN)

The Analog Control Input (AN. IN) allows the PS to be controlled as an “amplifier”; indeed, the PS generates an output which is proportional to the analog control input signal.

This Analog Control Input accepts signals ranging from -10V to +10V, corresponding to –Full-Scale to +Full-Scale of the PS output rating (it can be either current or voltage, depending on the Regulation Mode). An example of the relation between the analog input signal and the PS output is shown in **Figure 21**.

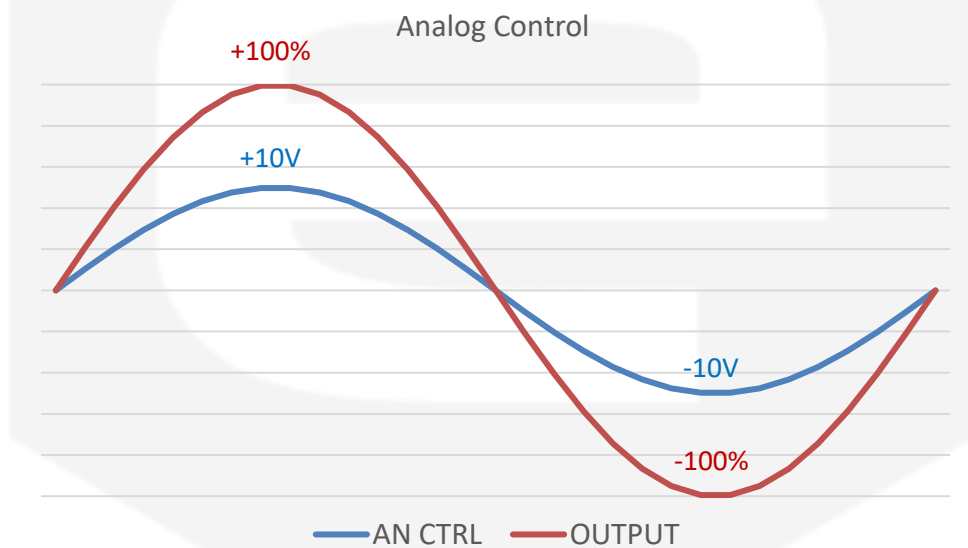

Figure 21: ANALOG CONTRL vs OUTPUT dependence

Please note that the bandwidth of the analog control input is internally limited to 1 kHz.

3.4.1 Configurable AUX Input (AUX. IN)

The Auxiliary Input (AUX. IN) connector allows connecting an external signal source or sensor that needs to be monitored, e.g. temperature sensors and field probes (Hall sensor).

The Auxiliary Input accepts signals ranging from -10V to +10V and the conversion value, identified by a scale-factor, can be stored in the PS in order to have the correct reading from it.

Example: for a temperature sensor having a 20 mV/°C gain, the input scale-factor needs to be configured considering that the equivalent temperature at a potential ADC full-scale of 5 V would be the following:

$$T_{FULL-SCALE} = \frac{5 V}{20 mV/°C} = 250 °C$$

Having the ADC a 16-bit resolution, the LSB value, equivalent to the scale-factor that needs to be saved to the PS for a correct reading is:

$$K_{LSB} = \frac{T_{FULL-SCALE}}{2^{16} - 1} \cong 0.0038 °C$$

3.4.2 K-type thermocouple connector

The option FB1K5OPT0001 includes the possibility to connect a K-type thermocouple. On board, the input signal coming from the thermocouple is digitized via an SPI interface.

Required thermocouple is K-type, with a reading temperature range from -200 °C to +1372 °C. Supported specifications are reported in **Table 3.5**.

DESCRIPTION	VALUE
Cold-junction temperature range	-55°C to +125°C
Cold-Junction Accuracy	±0.7°C (max, -20°C to +85°C)
Thermocouple Full Scale and Linearity Error	±0.15% (max, -20°C to +85°C)
Thermocouple Temperature Resolution	19-Bit, 0.0078125°C
Reads update rate	1s

Table 3.5: Supported Specifications for K-Type Thermocouple.

3.5 Output connectors

The load needs to be connected to the output connector placed on the PS rear panel. Two types of connectors are provided depending on the maximum output voltage of the PS.

3.5.1 High-Current (HC) Models

For High-Current models (HC, see **Table 1.1**), busbars terminals are present on the rear panel, see **Figure 22(a)**, to offer a convenient and reliable way of connecting the load. **Figure 22(b)** shows the output terminals with the protecting cover, while **Figure 23** shows a proper connection with the load cables (refer to section 2.5 for proper screws and cables characteristics).

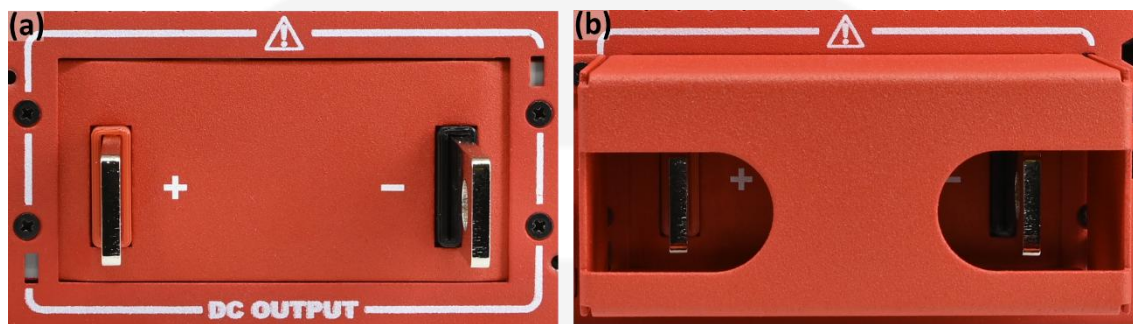

Figure 22: Output terminals for High Current models without (a) and with (b) cover, respectively.



Figure 23: Output terminals for High-Current models with cover and load connected.

WARNING

Maximum care shall be taken in order to isolate the output cables. Only isolated cables should exit the cover.

3.5.2 High-Voltage (HV) Models

For High-Voltage models (HV, see **Table 1.1**) a PCB terminal block (P/N: 2928703 Farnell) is provided on the rear panel, see **Figure 24**, suitable for cables from 0.75 mm² up to 10 mm² cross section. The terminal part of the cable has to be peeled and equipped with a ferrule 18 mm long (as it can be seen from **Figure 25**, ferrule on blue cable). Symbols “+” and “-” indicate the positive and negative polarity of the terminal, respectively.

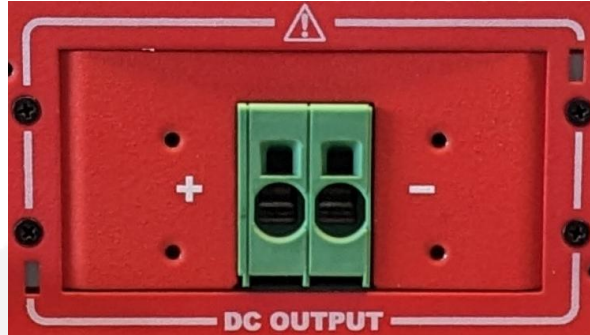

Figure 24: Output Connector for High-Voltage models, without cover.

The push-in mechanism ensures an easy and a long-term stable connection of the load. Indeed, for the connection it is sufficient to open the clamping space by means of a screwdriver. To insert or remove the load, push a screw driver at an angle similarly to **Figure 25** in order to open the clamp to insert or release the cable.

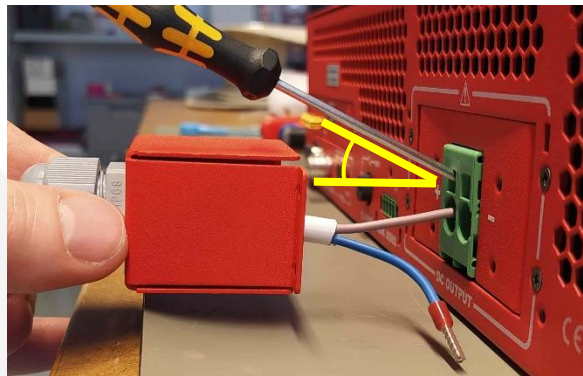

Figure 25: Insertion or Removal of the load cable from HV models. **Respect the screwdriver angle for a correct operation.**

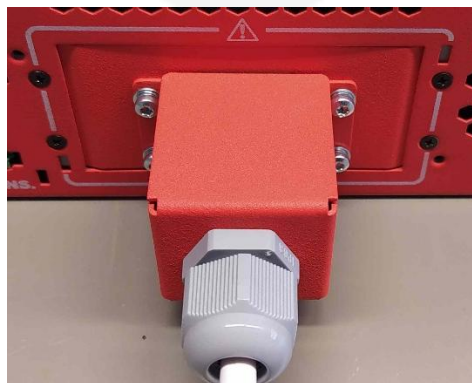

Figure 26: Output terminals of HV models with metallic cover and cable gland mounted.

3.6 Front Panel Indicators

The FAST-Bi-1K5 has four LED indicators on the front panel as shown in the following **Figure 27**.

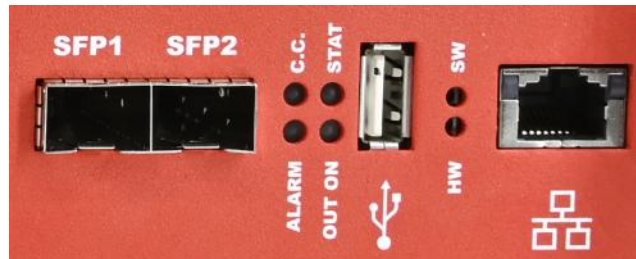

Figure 27: Front panel indicators

The front panel LED indicators and their behaviour are hereafter listed (clockwise starting from top-left):

- **C.C.:** Constant Current mode (**blue**). If turned on, the FAST-Bi-1K5 is working in constant current mode. When off, it regulates in Constant Voltage mode (C.V.);
- **STAT** (**green**): it signals the correct working-operation of the module diagnostics by blinking with 1-second period;
- **OUT ON** (**blue**): it signals that the output is enabled. The blue LED lights-up when output is enabled regulating either in C.V. or C.C. modes;
- **ALARM** (**red**): if turned on, it signals that one or more fault conditions has occurred. When the fault condition/cause has been removed, it is necessary to reset the PS fault status register in order to be able to enable the output of the PS again.

Additionally, the two push buttons indicated as “HW” and “SW” and the USB port are used for debug purpose only, do not use them.

3.7 Internal Protections

The FAST-Bi-1K5 is equipped with several internal protections (faults, see **Table 3.6**) that allow configuring the PS for optimal operation. These protections have the dual use of protecting the PS and the connected load/device from unwanted damages or undesired operation conditions.

Faults
Temperature
DC Link Fault
Input Overcurrent
Overpower
Earth Leakage
Earth Fuse
Regulation Fault
DCCT Error
Crow-bar
Quench
Output Overcurrent
Output Overvoltage
Interlock #1 #2 #3 #4
Parallel Configuration Error
Parallel Link Fault
Fans Error

Table 3.6: List of internal protections (faults).

Internal protections have configuration parameters (i.e., Quench intervention time, Earth Leakage Threshold, etc.) which are stored in the PS Internal Memory. The PS Internal Memory is structured as follows:

ID	Name	Value	Privileges
----	------	-------	------------

- *ID*: memory address (not editable);
- *Name*: name of the variable (not editable);
- *Value*: variable value (editable);
- *Privileges*: variable privileges (not editable).

The internal protection parameters (variables) can be changed in two ways:

1. From the GUI (see the “*Quick Start Guide*” for more information);
2. With TCP/IP commands (see the “*Commands Reference Manual*” for more information).

In the following sections the full list of internal protections is addressed. A brief description of the internal protections is presented with some more basic considerations on their operation and use. Additionally, for each internal protection are reported the configuration parameters (variables) and the respective Internal Memory addresses.

3.7.1 Temperature Fault

Internal monitoring of power stage temperature is performed. If the pre-defined threshold of 80 [°C] is exceeded for 1 [s] a fault condition is generated, thus disabling the PS output. The temperature has to go below threshold before being able to reset the fault status register and to enable the PS output again. The same fault condition is generated when the temperature sensor is disconnected.

3.7.2 DC-Link Fault

The FAST-Bi-1K5 is composed internally by a bidirectional power AC-DC section, cascaded with a DC-DC stage. The DC voltage generated by the AC-DC section is also called DC-Link and it is proportional to the maximum rated voltage of the specific model. Usually, the DC-Link voltage is about 20% higher than the rated output of the FAST-Bi-1K5. A continuous monitoring of the DC-Link voltage is performed in order to always guarantee the capability of obtaining the maximum voltage from the PS. If the DC-Link voltage either drops below or becomes larger than a set threshold, the regulation capabilities of the PS could be compromised and a fault condition is generated. The over/under voltage fault is triggered by a hardware circuit and, as mentioned, the thresholds are set taking into account the ratings of the specific model. It is necessary to reset the status register and to get rid of the fault cause before turning the PS back on again.

3.7.3 Input OverCurrent – OVC

The internal current drawn from the AC/DC module to every single power stage is sensed by a hall transducer. This current is compared with a threshold set in hardware. The threshold value of intervention depends on the FAST-Bi-1K5 specific model and cannot be changed by the user. The tripping of this fault generates a latched fault

condition. A reset of the PS fault status register needs to be performed in order to be able to enable the PS output again.

3.7.4 Earth Leakage

This protection continuously monitors the current flowing to earth and it has a settable threshold in [A] that can be set by experienced users. The tripping of this protection generates a fault condition that disables PS output.

Earth Leakage settings are configurable from the Internal Memory (Internal Memory addresses are reported in **Table 3.7**).

ID	Name
115	Earth Leakage Threshold [A]

Table 3.7: Earth Leakage settings parameters in Internal Memory.

3.7.5 Earth Fuse

An earth fuse is present on the rear side of the PS rated at 5A Class F. The blowing of this fuse generates a fault condition and the fuse needs to be replaced in order to get rid of the fault condition before resetting the PS fault status register. The fuse housing is shown in **Figure 28**.



Figure 28: Earth fuse housing.

3.7.6 Regulation Fault

This fault is generated when the PS is not able to properly regulate either in C.C. or in C.V. Thresholds for the differential current and differential voltage and intervention time can be set by experienced users. The tripping of this fault disables the PS output. A reset of the PS fault status register needs to be performed in order to be able to enable the PS output again.

E.g. Consider a 10-Ω load connected to a FAST-Bi-1K5 3050 (i.e. the maximum output voltage is 50 V). By setting a current of 10 A in C.C. mode, the output voltage should reach a value of 100 V, which is not feasible; so that, once the PS reaches 5 A,

it has already hit its maximum output voltage condition. The PS recognizes that is not able to cover the difference between the set-point (i.e. 10 A) and the actual output current and generates a “regulation fault” condition.

Regulation Fault settings are configurable from the Internal Memory (Internal Memory addresses are reported in **Table 3.8**).

ID	Name
120	Regulation Fault Intervention Time [s]
121	Current Regulation Fault Limit [A]
122	Voltage Regulation Fault Limit [V]

Table 3.8: Regulation Fault settings parameters in Internal Memory.

3.7.7 DCCT Error

The PS is continuously monitoring the status of the DCCT. If the DCCT experiences a fault, this is directly detected and the PS output switched OFF.

3.7.8 OverPower - OVP

The FAST-Bi-1K5 can work continuously at a 2% over its power rating as expressed in the specifications, **either in source or sink operation**. The module is able to work at a power comprised between 2% and 5% over its rating – i.e. between 102% and 105% – for a 120-second period before turning off on an over-power fault. If the actual output power drawn from the PS is more than 5% above its nominal ratings the PS output is automatically disabled after 1 second. This behaviour is summarized in the following **Table 3.9** (an example of a FAST-Bi-1K5 150 A 10 V is also listed):

Output Power	Time of Operation
< 102% of $ P_N $ < 1530 W	Continuous
< 105% of $ P_N $ < 1575 W	120 s
$\geq 105\%$ of $ P_N $ ≥ 1575 W	1 s

Table 3.9: Over-power logic characteristics for a FAST-Bi-1K5 150 A 10 V.

where $|P_N|$ is the rated nominal output power (indicated as absolute value to indicate source and sink operation) of the PS, as indicated in the technical specifications.

3.7.9 Crow-Bar

The energy stored in reactive loads – e.g. inductors – needs to be dissipated in order to protect the power supply from damages when, for example, the output gets suddenly disconnected. A hardware circuit, which includes voltage suppressors triggering semiconductor devices, is present on each FAST-Bi-1K5 model with different triggering thresholds. This circuit allows protecting the PS from unwanted and dangerous over-voltage conditions. Being a hardware protection, the crow-bar is fixed for every model and the intervention thresholds are different based on the FAST-Bi-1K5 maximum voltage rating.

The crow-bar can be triggered in three different ways:

1. Over-voltage condition (see **Table 3.10**),
2. Dedicated TCP-IP command (see the “*Commands Reference Manual*” for more details),
3. Loss of Mains or PS shutdown with the front panel power switch.

FAST-Bi-1K5 model	Over-voltage threshold
20-100	112 V
30-50	56 V
50-40	48 V
100-20	26 V
150-10	12.5 V

Table 3.10: Over-voltage thresholds.

The crow-bar circuit is powered with a super-capacitor which is capable, if completely charged, of maintaining active the crow-bar circuit up to 4 consecutive days (if mains are not present). The super-capacitor is recharged completely in 1 minute when the PS is connected to the AC Mains.

3.7.9.1 Crow-Bar Enable: rear panel connector

This connector is reserved for future uses.



Figure 29: Crow-bar enable connector on the rear panel.

3.7.10 Quench

This protection makes the FAST-Bi-1K5 a perfect fit for superconducting magnet operation. The PS continuously monitors the output voltage and current at the output and, as soon as a quench condition is detected, it turns off and triggers the crow-bar protection. Quench intervention time and thresholds are configurable by the user, in order to perfectly match the specific load.

The working operation of the quench protection are sketched in **Figure 30**.

The PS continuously monitors the load resistance, triggering a fault when either a minimum or maximum value is exceeded.

Quench settings are configurable from the Internal Memory (Internal Memory addresses are reported in **Table 3.11**).

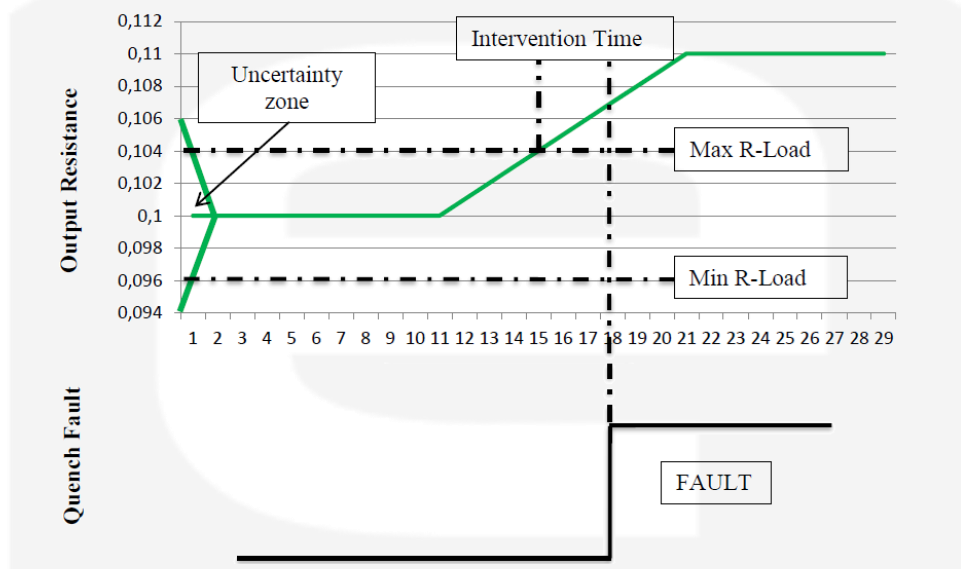

Figure 30: Quench detection working principle.

ID	Name
130	Quench Intervention Current Threshold [A]
131	Quench Max Magnet Resistance [Ohm]
132	Quench Min Magnet Resistance [Ohm]
133	Quench Intervention Time [s]
134	Enable Quench Detection during ramp [0 1]

Table 3.11: Quench settings parameters in Internal Memory.

3.7.11 Output Overcurrent/Overvoltage

The PS allows the user to set an output limit on the output current and/or voltage. If the limits are exceeded, the PS output is automatically switched OFF. The limits can be set either by the GUI or by TCP/IP commands (for the TCP/IP commands refer to the “*Commands Reference Manual*”).

Output Overcurrent/overvoltage settings are configurable from the Internal Memory (Internal Memory addresses are reported in **Table 3.12**).

ID	Name
100	Output Over-Current Limit [A]
101	Output Over-Voltage Limit [V]

Table 3.12: Output Overcurrent/overvoltage settings parameters in Internal Memory.

3.7.12 Interlock #1 #2 #3 #4

Internal protections are also available through four interlocks. Interlocks can be easily configured from the GUI. Connections of the interlocks are provided from the rear panel of the PS, refer to section 3.1 for more information. For more information about interlocks configuration refer to the “*Commands Reference Manual*” and to the “*Quick Start Guide*”.

Output Overcurrent/overvoltage settings are configurable from the Internal Memory (Internal Memory addresses are reported in **Table 3.13**).

ID	Name
140	Interlock Enable Mask
141	Interlock Activation Level Mask
144	Interlock #1 Intervention Time [ms]
145	Interlock #1 Name
146	Interlock #2 Intervention Time [ms]
147	Interlock #2 Name
148	Interlock #3 Intervention Time [ms]
149	Interlock #3 Name
150	Interlock #4 Intervention Time [ms]
151	Interlock #4 Name

Table 3.13: Interlock settings parameters in Internal Memory.

3.7.1 Parallel Link Fault

This fault is related to the parallel operation of the PS and it indicates that the SFP/SFP+ link is not working properly. See section 4.2 for more information.

3.7.2 Parallel Configuration Error

This fault is related to the parallel operation of the PS and it indicates that the PSs are not the same model or they do not have the same firmware version installed. See section 4.2 for more information.

3.7.3 Fans Error

The PS constantly monitors the status of the fans. If one or more fans are not working correctly the PS output is automatically switched OFF. If this fault cannot be reset, even after a power-cycle, the PS has to be sent back for repair (see RMA procedure section).

4. Advanced Functions

4.1 Waveform

The FAST-Bi-1K5 is able to act as a waveform generator both in C.C. and C.V. regulation modes. The waveform is stored internally in a point-by-point list; the maximum number of points of the waveform and the sampling period (of the waveform execution) can be defined by the user, giving flexibility to the waveform generator applicability. The minimum time interval for the waveform execution period is limited to $0.01\text{ ms} = 10\text{ }\mu\text{s}$, resulting in an output waveform update rate of 100 kHz. In order to correctly execute the output waveform, it is necessary to properly tune the PID regulator parameters of the PS for the specific load in use.

More information on the waveform feature can be found in the “*Quick Start Guide*” and in the “*Commands Reference Manual*”.

4.2 Parallel Operation

FAST-Bi-1K5 modules can be run in parallel operation, thus increasing the output current of the paralleled solution while maintaining the same voltage of each building block.

CAUTION

- Up to 4 PS can be connected in parallel configuration.
- Only PS of the same model and same firmware version can be connected in parallel configuration.
- Interlocks have to be connected only to the MASTER PS.

To configure correctly the PSs for the parallel mode follow the next steps:

Remove the caps from the optical cable (

- **Figure 31):**



Figure 31

- To release the plugs from the slot to prepare the daisy-chain connection, pull back the white sheath from the cable (blue arrow) and push the connector forward (green arrow);

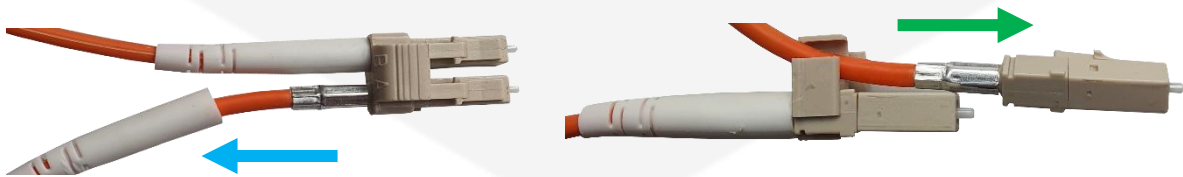

- Connect the SFP/SFP+ optical transceiver module into the SFP1 slot on the front panel of the PS (**Figure 32**);



Figure 32

- Insert the SFP/SFP+ optical cables into the optical transceivers following the connections reported in
- **Figure 33** (orange lines);

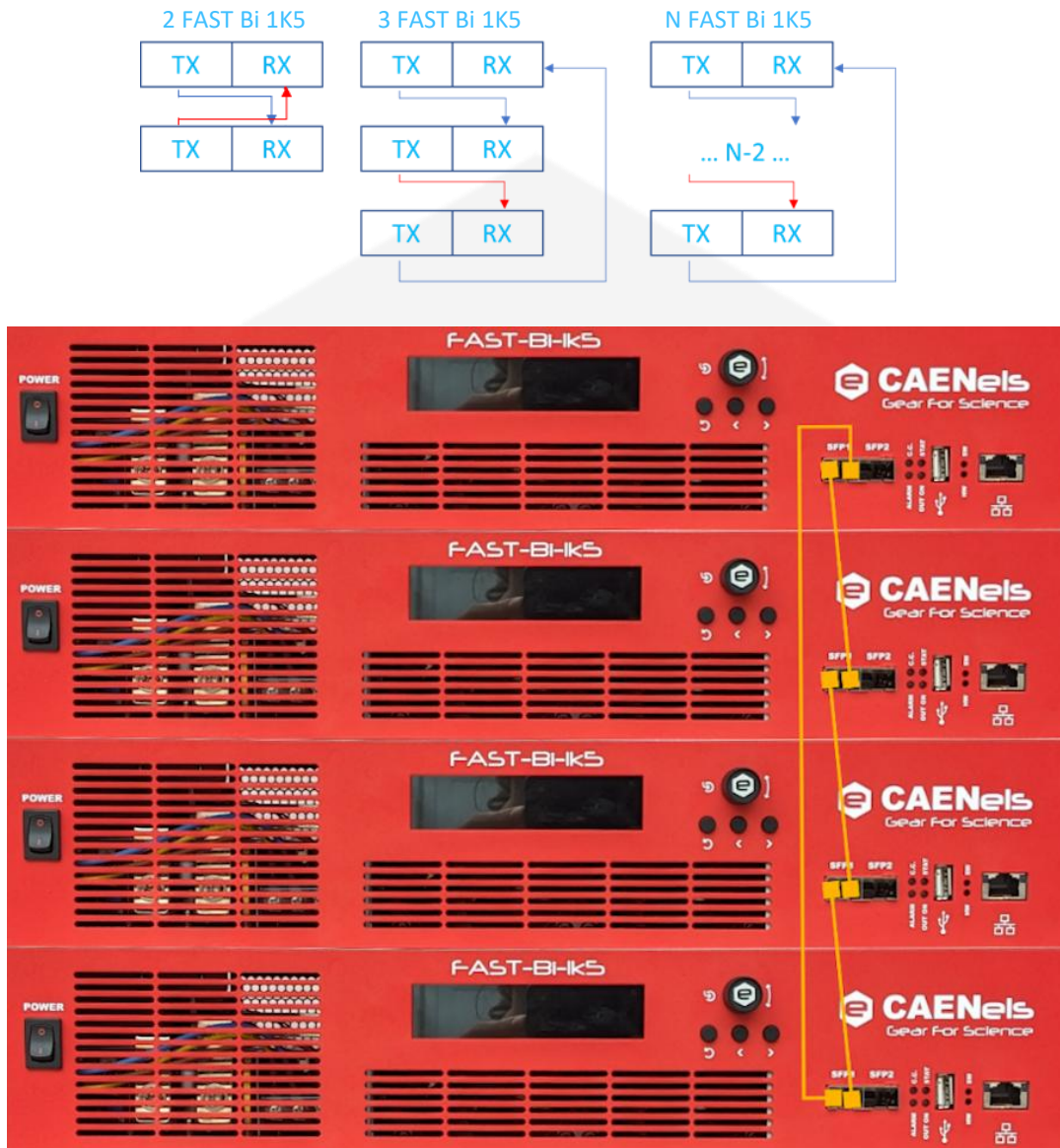

Figure 33: Parallel configuration, front panel.

- Connect PS output terminals with proper cables or busbars (see section 4.3) in order to put the PSs in parallel configuration following the connections reported in **Figure 34** (blue and red lines);
- Connect the crow-bar cables on the rear panel following the connections reported in **Figure 34** (orange lines);

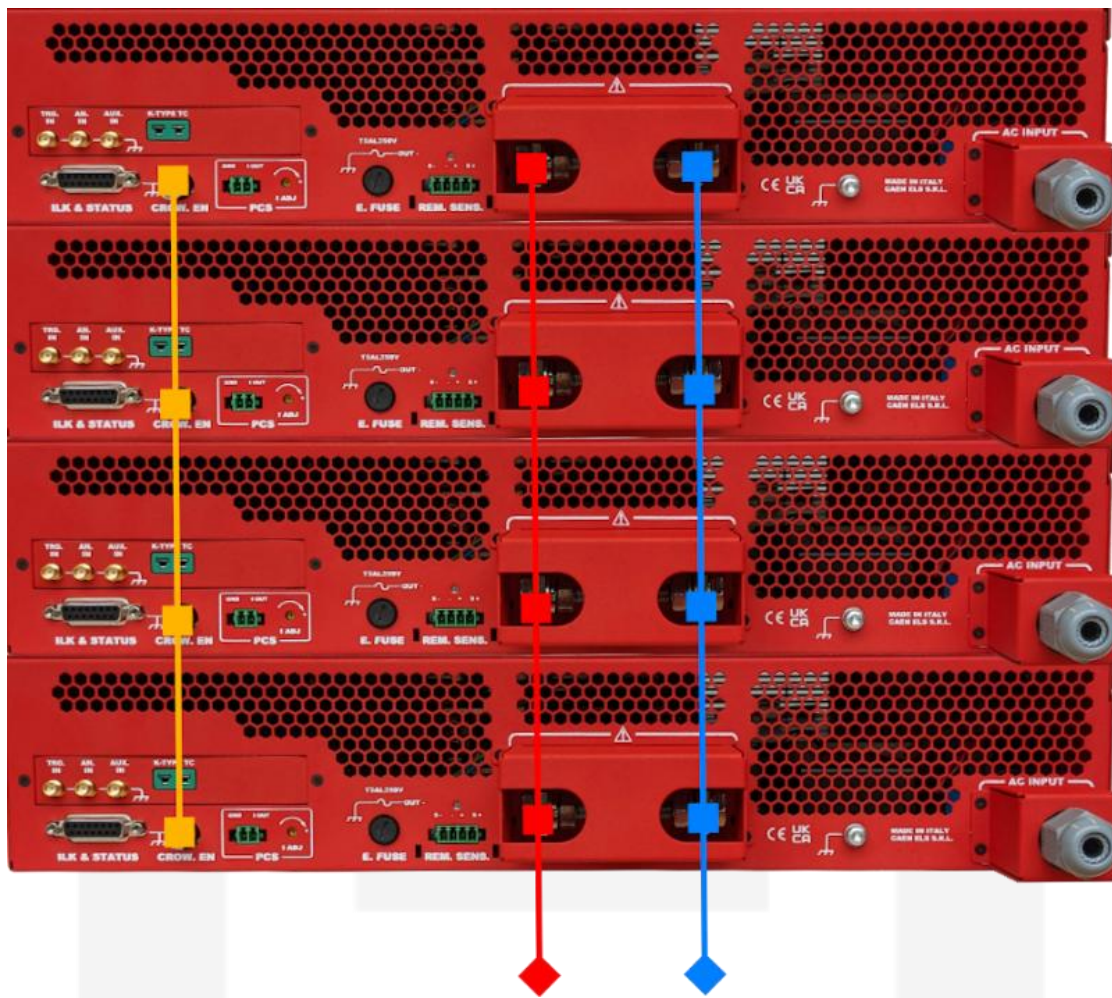

Figure 34: Parallel configuration, rear panel.

- Remove the earth fuse from all the PSs which will be configured as SLAVE;
- Mount the earth fuse on the MASTER PS to set it to grounded mode, or remove it to set the PS to floating mode (see section 3.7.5).
- Power-on the PSs;
- Access the *Config Page* from *MENU* or *LCL – RMT* icons on the *Home Screen* and enable Local Control on all the devices by selecting *LCL* icon;
- Set all the SLAVE PSs in floating mode from *Config page* by selecting the *FLTN* icon;
- Set the MASTER PS in floating or grounded mode from *Config page* by selecting *FLTN* or *MSTR* icon;
- Set the MASTER PS as *Master* from the *Config page* by selecting *MSTR* icon. A fault will be generated until the parallel configuration is not complete;

- Set all the SLAVE PSs as *Slave* from the *Config page* by selecting *SLV* icon;
- Access the *Fault page* from *MENU* or *FLT* icons on the *Home Screen* and clear all the fault in the MASTER PS by selecting *RESET FAULT* rectangle;

If it is not possible to clear the faults, the Parallel Operation is not configured correctly. Check the configuration procedure again.

- To enable remote operation set the remote control on MASTER PS from *Config page* by selecting *RTM* icon.

Once these steps are completed the PSs operate as a single unit, which is the MASTER PS.

Additional information on the parallel feature can be found in the “Quick Start Guide”.

4.3 Parallel Busbar Kit

To connect multiple PS units in parallel, Busbar Kit accessories are available in two-, three-, or four-channel configurations, allowing the parallel connection of two, three, or four devices, respectively.

4.3.1 Parallel Busbar Kit mounting instructions

The following procedure shows the mounting instructions for a two-channel configuration as an example.

The Parallel Busbar Kit is composed of a left and right busbar, a protection cover and the mounting hardware, as shown in **Figure 35**:



Figure 35: Busbar and Protection kit

The FAST-BI-1K5 units must be mounted in a rack system. As a first step, the parallel busbars shall be mounted to the output busbars of the PS unit. Ensure that the top side of each busbar is properly aligned.

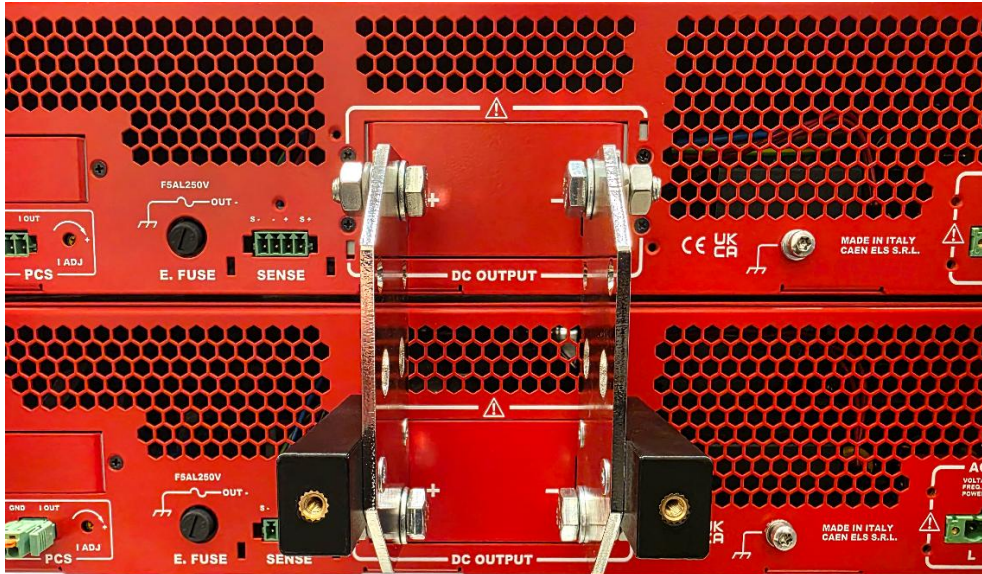

Figure 36: mounting busbars

Use four M8×20 bolts with two flat washers, one spring washer, and a nut to secure the parallel busbars; maximum tightening torque: 15 Nm.

Mount the load cables referring to the Load Connection section (2.5); Add one cable per pole for each PS unit.



2.5Figure 37: Load cables connection

Use M10×25 bolts with two flat washers, one spring washer, and a nut to secure the load cables; maximum tightening torque: 33 Nm.

Mount the protection cover over the parallel busbars.



Figure 38: Protection cover

Use M4×12 Torx pan washer head screws to secure the cover; maximum tightening torque: 1 Nm.

5. Mechanical Dimensions

The mechanical dimensions of the PS are hereafter presented:

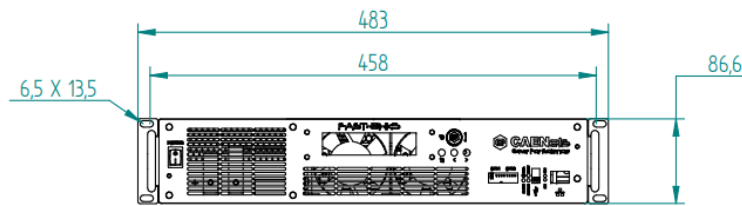

Figure 39: FAST-Bi-1K5 Mechanical Drawings of the Front Panel.

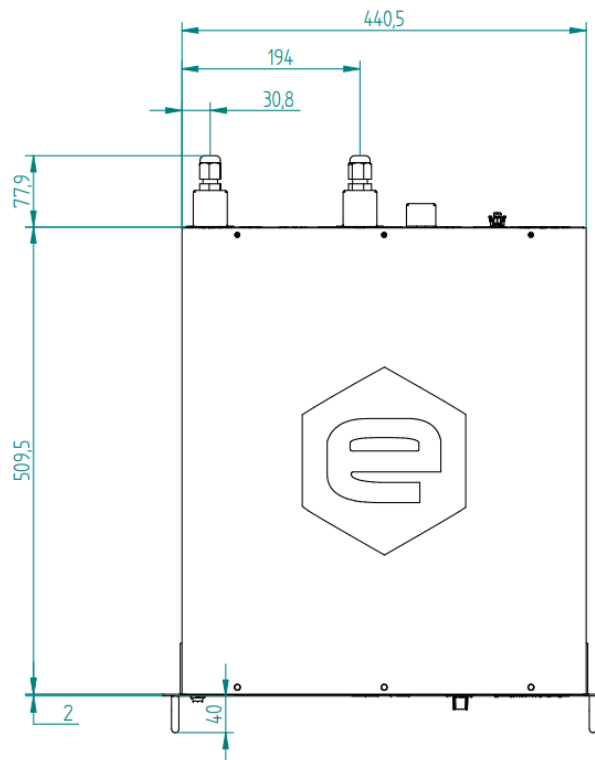

Figure 40: FAST-Bi-1K5 Mechanical Drawings for the HV models.

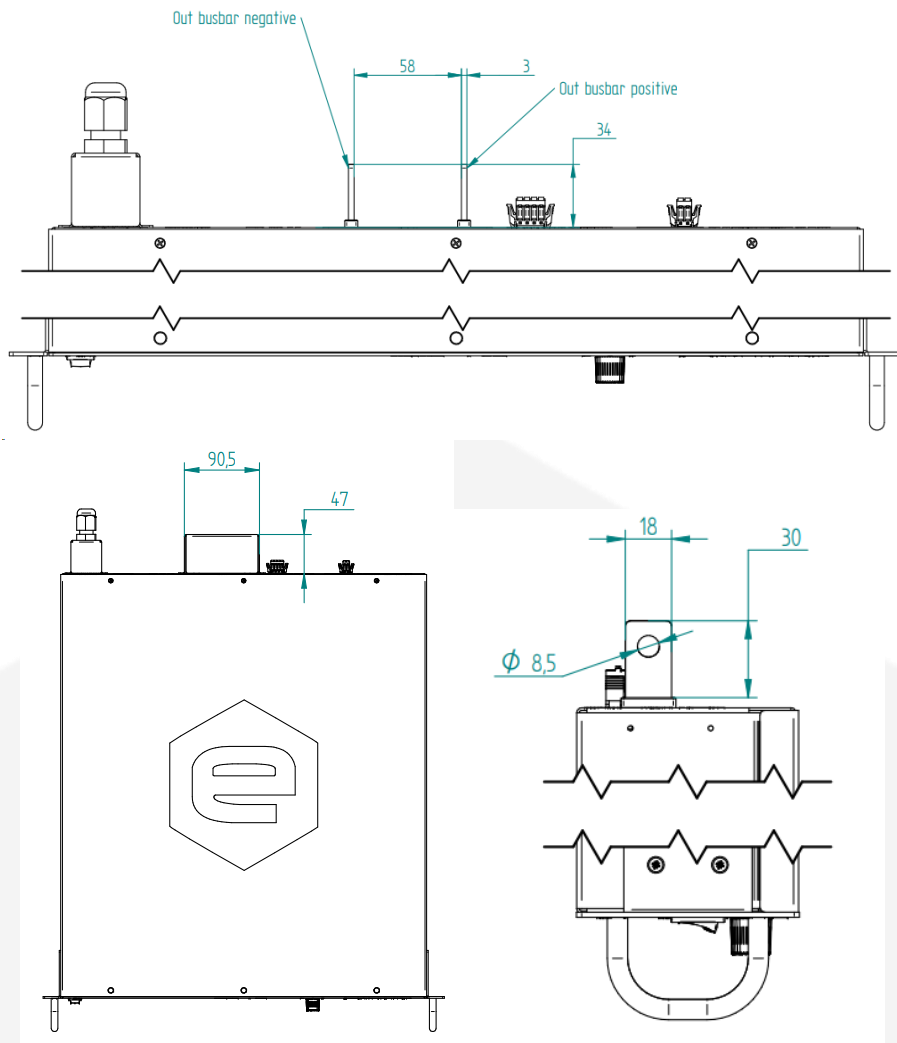

Figure 41: FAST-Bi-1K5 Mechanical Drawings for the HC models.

6. Technical Specifications

The main technical specifications for the standard FAST-Bi-1K5 HC models are hereafter presented:

Technical Specifications	FAST-Bi-1K5 HC Models		
	50-40	100-20	150-10
Output Current	±50 A	±100 A	±150 A
Output Voltage	±40 V	±20 V	±10 V
Rated Output Power	1500 W		
Topology	Full 4-Quadrant		
Regulation Mode	Constant Current (C.C.) and Constant Voltage (C.V.)		
Remote Sensing	up to 0.5 V		
Current Sensing	Internal High-Precision Current Transducers		
Current Setting Resolution	24-bit		
Voltage Setting Resolution	24-bit		
Output Readback Resolution	24-bit		
Switching Frequency (equivalent)	200 kHz	400 kHz	
Efficiency AC/DC	> 87 %	> 86 %	> 80 %
Efficiency DC/AC	> 90 %	> 87 %	> 80 %
Output Accuracy RMS	< 0.01 %		
Temperature Stability	< 2 ppm/K/FS		
Long Term Stability (8 h)	< 10 ppm/FS		
V_{OUT} Ripple*	<2 mV _{RMS}	<1 mV _{RMS}	<0.5 mV _{RMS}
I_{OUT} Ripple**	<1 mA _{RMS}	<0.5 mA _{RMS}	<1.5 mA _{RMS}
Analog Bandwidth (-3 dB)	3.9 kHz	5.4 kHz	5.3 kHz
Rise time 10-90%	< 90 μs	< 66 μs	< 65 μs
Analog Bandwidth (-3 dB) with FB1K5OPT0002 (High-Bandwidth)	4.6 kHz	7.2 kHz	7 kHz
Rise time 10-90% with FB1K5OPT0002 (High-Bandwidth)	< 70 μs	< 48 μs	< 48 μs
Cooling	Forced air convection		

Control/Communication Interface	Ethernet 10/100/1000 Mbit TCP-IP or UDP SFP/SFP+		
Local Control	Color display with multi-function navigation switch		
External Signals	4 x External Interlock Inputs (configurable dry contacts) 1 x Status Output Relay (magnetic) 1 x Output Relay (solid state) 1 x Persistent Switch Output		
Optional Features (code FB1K5OPT0001)	1 x Trigger Input (LVTTTL, TTL) 1 x Analog Control Input (± 10 V) 1 x Auxiliary ADC Input (16 bit, 100 ksps) 1 x K-type Thermocouple Input		
Extra Features	Waveform execution Quench Protection Remote Firmware Update Linux OS on-board		
Auxiliary Readbacks	DC-Link Voltage Ground Leakage Current Temperature		
Hardware Protections	Input Fuses Crowbar (Over-Voltage)		
Mechanical Dimensions (L×W×H)	19" x 2U x 587 mm (including connectors)		
Input Ratings	180 - 264 VAC / 47 - 63 Hz		
Weight (typ.)	15 kg	15 kg	15 kg
Operating Ambient Temperature	0 ... 50 °C		
Audible Noise Level (No Load / 50% Load / 80% Load / 100% Load)	47 dB / 53 dB / 61 dB / 67 dB		

* With output filter at 1 kHz bandwidth.

** With output filter at 1 kHz bandwidth, Load = $R_{\text{Max Power}} + 1 \text{ mH}$.

Table 6.1: FAST-Bi-1K5 HC models technical specifications.

The main technical specifications for the standard FAST-Bi-1K5 HV models are hereafter presented:

Technical Specifications	FAST-Bi-1K5 HV Models	
	20-100	30-50
Output Current	±20 A	±30 A
Output Voltage	±100 V	±50 V
Rated Output Power	2000 W	1500 W
Topology	Full 4-Quadrant	
Regulation Mode	Constant Current (C.C.) and Constant Voltage (C.V.)	
Remote Sensing	up to 0.5 V	
Current Sensing	Internal High-Precision Current Transducers	
Current Setting Resolution	24-bit	
Voltage Setting Resolution	24-bit	
Output Readback Resolution	24-bit	
Switching Frequency (equivalent)	200 kHz	400 kHz
Efficiency AC/DC	> 89 %	> 87 %
Efficiency DC/AC	> 76 %	> 80 %
Output Accuracy RMS	< 0.01 %	
Temperature Stability	< 2 ppm/K/FS	
Long Term Stability (8 h)	< 10 ppm/FS	
V_{OUT} Ripple*	<3 mV _{RMS}	<1.2 mV _{RMS}
I_{OUT} Ripple**	<0.3 mA _{RMS}	<0.5 mA _{RMS}
Analog Bandwidth (-3 dB)	3.9 kHz	3.4 kHz
Rise time 10-90%	< 90 μs	<100 μs
Analog Bandwidth (-3 dB) with FB1K5OPT0002 (High-Bandwidth)	4.1 kHz	5 kHz
Rise time 10-90% with FB1K5OPT0002 (High-Bandwidth)	< 85 μs	86 μs
Cooling	Forced air convection	
Control/Communication Interface	Ethernet 10/100/1000 Mbit TCP-IP or UDP SFP/SFP+	
Local Control	Color display with multi-function navigation switch	
External Signals	4 x External Interlock Inputs (configurable dry contacts) 1 x Status Output Relay (magnetic)	

	1 x Output Relay (solid state) 1 x Persistent Switch Output
Optional Features (code FB1K5OPT0001)	1 x Trigger Input (LVTTTL, TTL) 1 x Analog Control Input (± 10 V) 1 x Auxiliary ADC Input (16 bit, 100 ksp/s) 1 x K-type Thermocouple Input
Extra Features	Waveform execution Quench Protection Remote Firmware Update Linux OS on-board
sAuxiliary Readbacks	DC-Link Voltage Ground Leakage Current Temperature
Hardware Protections	Input Fuses Crowbar (Over-Voltage)
Mechanical Dimensions (L×W×H)	19" x 2U x 587 mm (including connectors)
Input Ratings	180 - 264 VAC / 47 - 63 Hz
Weight (typ.)	15 kg
Operating Ambient Temperature	0 ... 50 °C
Audible Noise Level (No Load / 50% Load / 80% Load / 100% Load)	47 dB / 53 dB / 61 dB / 67 dB

* With output filter at 1 kHz bandwidth.

** With output filter at 1 kHz bandwidth, Load = $R_{\text{Max Power}} + 1 \text{ mH}$.

Table 6.2: FAST-Bi-1K5 HC models technical specifications.