

REGUL8OR

Digital High-Performance Programmable Power Supply Controller



User's Manual



All Rights Reserved
© CAEN ELS s.r.l.
Rev. 5 – March 2026



This product is **CE** & **UKCA** compliant.



CAEN ELS s.r.l.

Via Karl Ludwig Von Bruck 32– 34144 Trieste (TS)

Italy

Mail: info@caenels.com

Web: www.caenels.com



User’s Manual – Models – Options – Custom Models

This manual covers the following standard REGUL8OR models:

Model	Ordering code
REGUL8OR	REGUL8ORXAAA
REGUL8OR DCCT VOLTAGE	REGUL8ORXC1A

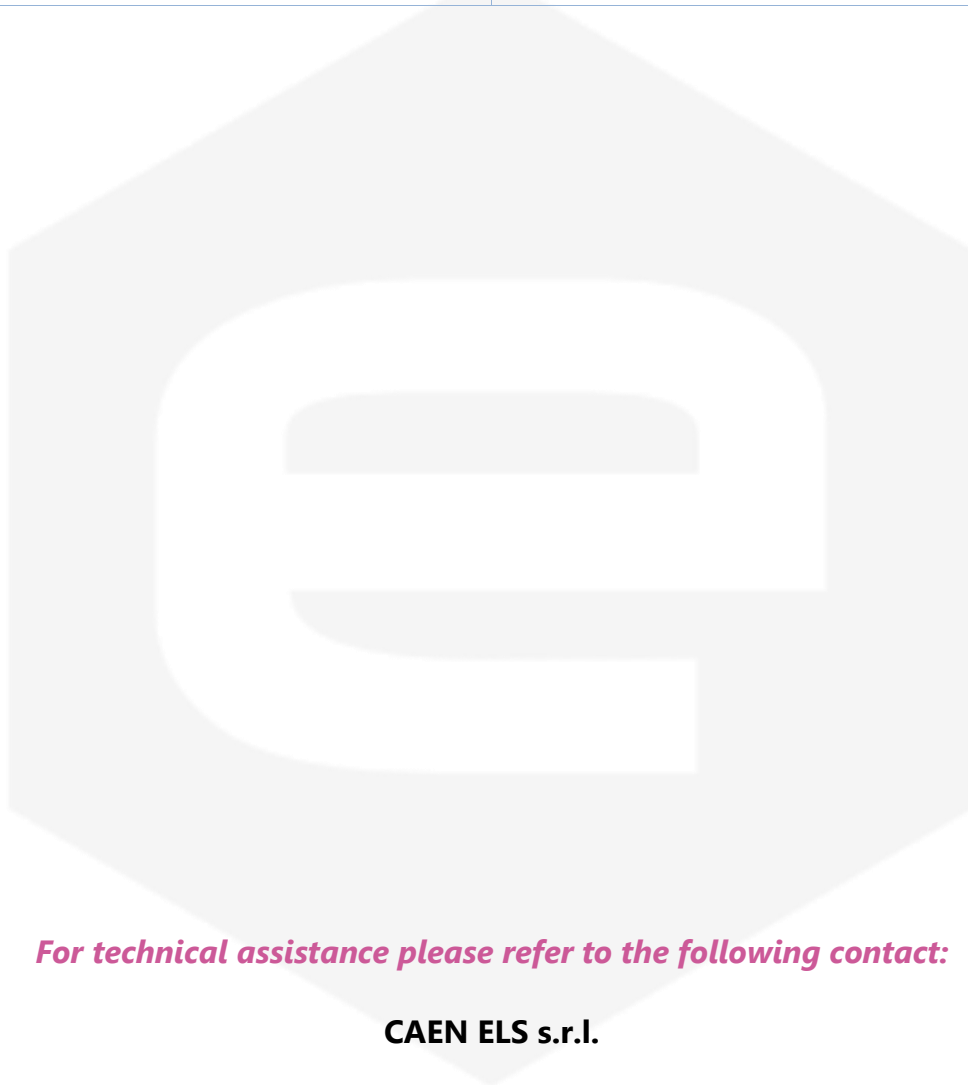

For technical assistance please refer to the following contact:

CAEN ELS s.r.l.

Karl Ludwig Von Bruck 32
34144 Trieste (TS) – Italy

Phone: +39 040 883 0028

Table Of Contents

1. INTRODUCTION.....	10
1.1 REGUL8OR OVERVIEW	10
1.1.1 REGUL8OR DCCT VOLTAGE Overview	12
1.2 REGUL8OR AT A GLANCE	13
1.2.1 DCCT – Direct Current Transducer	14
1.2.2 Digital Control Loop.....	15
1.3 OPERATION MODES	16
1.3.1 Regulation Mode.....	16
1.3.2 Control Mode.....	16
1.3.3 Update Mode.....	17
1.4 EXTERNAL INTERLOCKS AND STATUS SIGNALS	18
1.4.1 Interlock Enable/Disable Mask.....	18
1.4.2 Interlock Activation Level Mask	18
1.4.3 Interlock Intervention Time.....	19
1.4.4 Interlock Isolation.....	19
1.4.5 Output Status Signal – User-Defined.....	19
1.5 TRIGGER AND ANALOG CONTROL INPUTS.....	20
1.5.1 Trigger input.....	20
1.5.2 Analog Control Input	21
1.6 EXTERNAL SENSORS	22
1.7 SYNCHRONIZATION OF MULTIPLE UNITS	23
1.8 EXTERNAL SPI.....	23
1.9 OUTPUT CONNECTORS	24
1.10 CURRENT CONNECTORS AND INPUT VOLTAGE	25
1.11 FRONT PANEL INDICATORS	26
1.12 INTERNAL PROTECTIONS.....	27
1.12.1 Regulation Fault	27
1.12.2 OVerTemperature - OVT	27
1.13 WAVEFORM	28
2. INSTALLATION.....	28
2.1 PREPARATION FOR USE	28
2.2 INITIAL INSPECTION	29
2.3 MOUNTING.....	29
2.3.1 Rack Mounting.....	29
2.4 AC INPUT POWER CONNECTION	30
2.4.1 AC Source Requirements	30
2.4.2 AC Input Cord.....	30
2.5 EXTERNAL POWER SUPPLY CONNECTION	31
2.6 CABLE LENGTH.....	32
2.7 INTERLOCK AND STATUS SIGNALS.....	32
2.8 EXTERNAL SENSORS	35
2.9 EXTERNAL SPI.....	36
2.10 TRIGGER AND ANALOG CONTROL INPUTS	37
2.11 ISOLATED OUTPUT CONNECTORS	38
2.12 SYNC IN AND SYNC OUT.....	39

2.13	CURRENT AND VOLTAGE INPUTS	40
2.14	INSULATION	41
2.15	MATING CONNECTORS.....	42
3.	LOCAL CONTROL	43
3.1	NAVIGATION BUTTONS AND ROTARY ENCODER KNOB	43
3.2	DISPLAY.....	44
3.2.1	<i>Power-up</i>	44
3.2.2	<i>Home Screen</i>	44
3.2.3	<i>Menu Page</i>	45
3.2.3.1	Control Page.....	46
3.2.3.2	Config Page.....	47
3.2.3.3	Advanced Page.....	47
4.	MECHANICAL DIMENSIONS.....	49
5.	TECHNICAL SPECIFICATIONS	50

Document Revisions



Revision	Date	Comment
1.0	October 2 nd , 2020	First Release
1.1	October 7 th , 2020	Corrections made on several sections
1.2	May 21 st , 2021	Updated Local Control Section
1.3	November 22 nd , 2022	Added UKCA compliance logo
1.4	November 14 th , 2023	Added Sec.2.16 on the setup of Regul8OR-power supply system
2	August 8 th , 2024	Updated address and revision numbering
3	July 8 th , 2025	Added Regul8OR DCCT Voltage model
4	September 22 nd , 2025	Updated DCCT cable connections sec.1.10 Added DCCT cable types table sec. 2.13 Added TDK-Lambda configuration sec.2.17
5	March 12 th , 2026	Removed Regul8OR PWM model and minor corrections

Safety information

The following table shows the general environmental requirements for a correct operation of instruments referred in this User's Manual:

Environmental Conditions	Requirements
Environment	Indoor use
Operating Temperature	0°C to 40°C
Operating Humidity	20% to 80% RH (non-condensing)
Altitude	Up to 2000 m
Pollution degree	2
Overtoltage Category	II
Storage Temperature	-10°C to 60°C
Storage Humidity	5% to 90% RH (non-condensing)

The following symbols are used within this manual or are reported in the box and along this manual:

-  **CAUTION Risk of Electrical Shock**
-  Caution: Documentation must be consulted in all cases where this symbol is marked
- **0** Off (Power)
- **I** On (Power)
-  **WARNING** The WARNING sign denotes a hazard. An attention to a procedure is called. Not following the procedure correctly could result in personal injury. A WARNING sign should not be skipped and all indicated conditions must be fully understood and met.

CAUTION

- The CAUTION sign denotes a hazard. An attention to a procedure is called. Not following procedure correctly could result in damage to the equipment. Do not proceed beyond a CAUTION sign until all indicated conditions are fully understood and met.

CAEN ELS s.r.l. will repair or replace any product within the guarantee period if the Guarantor declares that the product is defective due to workmanship or materials and has not been caused by mishandling, negligence on behalf of the User, accident or any abnormal conditions or operations.

Please read carefully the manual before operating any part of the instrument

WARNING

**Do NOT open the
TOP COVER of the BOX**

CAEN ELS s.r.l. declines all responsibility for damages or injuries caused by an improper use of the Modules due to negligence on behalf of the User. It is strongly recommended to read thoroughly this User's Manual before any kind of operation.

CAEN ELS s.r.l. reserves the right to change partially or entirely the contents of this Manual at any time and without giving any notice.

Disposal of the Product

The product must never be dumped in the Municipal Waste. Please check your local regulations for disposal of electronics products.



WARNING

- Do not use this product in any manner not specified by the manufacturer. The protective features of this product may be impaired if it is used in a manner not specified in this manual.
- Do not use the device if it is damaged. Before you use the device, inspect the instrument for possible cracks or breaks before each use.
- Do not operate the device around explosive gases, vapor or dust.
- Always use the device with the cables provided.
- Turn off the device before establishing any connection.
- Do not operate the device with the cover removed or loosened.
- Do not install substitute parts or perform any unauthorized modification to the product.
- Return the product to the manufacturer for service and repair to ensure that safety features are maintained

1. Introduction

This chapter describes the general characteristics and main features of the REGUL8OR controller series.

1.1 REGUL8OR Overview

The REGUL8OR is a high-performance and high-stability digital controller and can be used with all the COTS (Commercial Off-The-Shelf) programmable power supplies that accept an analog control input ranging from:

- 0 V ... +5 V (UNIPOLAR)
- 0 V ... +10 V (UNIPOLAR)
- -5 V ... +5V (BIPOLAR)
- - 10 V ... +10 V (BIPOLAR)

or a current 4-20 mA input to improve their specifications over different aspects.

Thanks to the GUI (Graphic User Interface), the control and configuration of the REGUL8OR is straightforward. At the rear of the module, several interfaces allow quick and easy connection to the external power supply, thus providing additional functionalities.

The high level of versatility of the device is given by the possibility to choose, on the same hardware module, between several current and voltage input ranges, as listed in the following.

The current ranges available are:

- ± 100 A, ± 150 A, ± 200 A, ± 300 A, ± 400 A, ± 600 A, ± 1000 A.

For the REGUL8OR DCCT VOLTAGE model a voltage output DCCT with output ranges from -10 V to + 10 V can be used. If CAEN ELS' DCCTs are used it is possible to have 2 kA and 3 kA current ranges.

The voltage ranges available are:

- ± 5 A, ± 10 A, ± 20 A, ± 50 A, ± 100 A, ± 200 A.

The REGUL8OR module is housed in a compact mechanical format and fits in a single 19” - 1U standard crate. The device implements a completely digital control loop with a 1-MSPS, 20-bit Digital-to-Analog Converter (DAC) that allows adapting the system to basically any general-purpose programmable power supply. The behavior of device is schematically described in **Figure 1**:

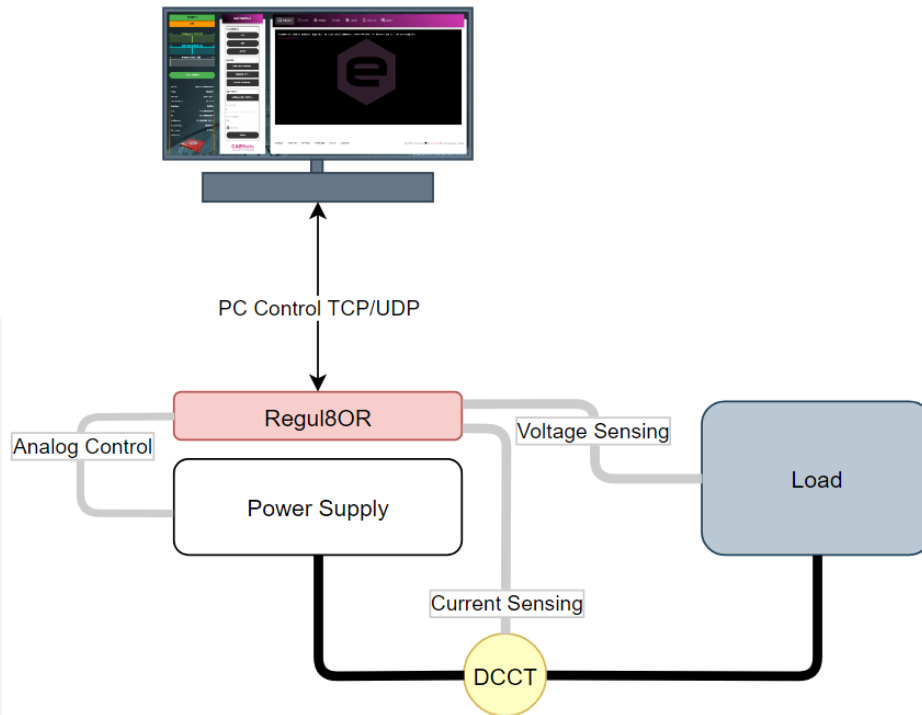

Figure 1: Schematic representation of the REGUL8OR coupled to an external power supply. The digital controller generates an analog voltage signal to control the external power supply, which in turn acts as an amplifier and generates the current (or voltage) desired. The REGUL8OR then closes the voltage and current loops and elaborates the values in a digital PID.

The REGUL8OR is a digital control device that uses two 24-bit Analog-to-Digital Converters (ADCs), one for the voltage input path and the other for the current input path, to sense the external current and voltage generated by the general-purpose power unit controlled, in order to compute them in a digital PID controller which in turn produces the analog voltage output (or the 4-20 mA) to control the COTS power supply.

The control board houses a dedicated SoC (System on Chip), including an FPGA with an integrated dual-core ARM CPU. The loop regulation task is performed directly by the FPGA logic, in order to have high performance and deterministic loop control. An embedded Linux OS is installed on the ARM CPU, supervising all processes as well as communication, diagnostics and local interface handling.

Remote communication is guaranteed by means of an Ethernet 10/100/1000 Mbit autosensing socket present on the front panel of the device on a RJ45 connector.

The REGUL8OR can also be monitored and controlled via a navigation switch and a graphic high-resolution color display featuring user-friendly menus.

In addition to the standard Ethernet interface, it is possible to communicate with the unit using the SFP-ports on the front panel. This interface allows communicating with the unit using a proprietary protocol (packet structure with a very high update rate (more than 10 kHz) for fast applications. These ports are connected directly to the FPGA logic and so the given packet is elaborated directly by the hardware logic.

This approach eliminates the software stratification that manages the packet and the computational time is smaller and deterministic, allowing a very high update rate of the setpoint, giving the user more flexibility and excellent rates for the digital remote control of the power supply.

1.1.1 REGUL8OR DCCT VOLTAGE Overview

While maintaining the performance and technical features of the REGUL8OR, the REGUL8OR DCCT VOLTAGE is designed to accept voltage input signals from DCCT current transducers with voltage output, allowing for easier connection to the Analog-to-Digital Converter (ADC) of the REGUL8OR DCCT VOLTAGE unit.

The current conversion to a full-scale bipolar output signal V_0 of the BNC is as follows:

- +10V output if the primary current is equal to positive full scale of the sensor;
- –10V output if the primary current is equal to negative full scale of the sensor.

The device offers the possibility to choose from several voltage input ranges and to extend the maximum current capabilities, with ranges of 2000 A and 3000 A by using CAEN ELS’ CT-2000 and CT-3000

1.2 REGUL8OR at a glance

The REGUL8OR system is composed by a single 19-inch 1U crate. The unit and its I/O connections can be easily seen in **Figure 2** (front view), and **Figure 3** (rear view).



Figure 2: REGUL8OR front view

On the front side of the REGUL8OR unit there are placed respectively: a power switch, a colour graphic display with navigation switch for the local control of the module, three communication sockets (2 SFPs and one Ethernet port), four status LEDs and one USB device connector.



Figure 3: REGUL8OR rear view

On the rear side of the unit an AC power line input and all of the connectors for communicating with external devices are placed. A brief description of the connectors used are described in the **Table 1**.

Connector Name	Connector Type	Description
Interlocks and Status Signals	D-SUB25	6 external interlocks (four dry-contact types and two 24-V type ones) that can be used to capture external faults. Six signal status are also present on the same connector: 2 TTL signals (5 V), 2 magnetic relays with NO and NC contacts and 2 solid state relays
Trigger Input	Isolated BNC	Trigger Input connectors, can be used as a hardware start, or for the execution of a pre-loaded waveform
Sync In and Sync Out	SMA	Used to connect many power supplies in parallel or to synchronize their operation: SYNC IN and SYNC OUT signals is used to maintain different units in-phase.
External SPI	8-pin Right-Angle	This connector allows to add new modules to the REGUL8OR
External Sensors	D-SUB9 Male	Used to connect external sensors to the REGUL8OR, e. g. external temperature sensor or a hall probe.

Connector Name	Connector Type	Description
Analog Input	Isolated BNC	The control board can be controlled not only by using the digital communication interface but also with an external analog signal. Input voltage range span from -10 V to +10 V (or can be selected 5 V range)
DCCT – Current Transducer	D-SUB9 Female	Thanks to this connector an external DCCT can be connected to the REGUL8OR for measuring the current
Output Voltage DAC	Isolated BNC	BNC used to control the external power supply. The voltage output is also available on the LEMO connector together with the 4-20 mA output
4-20 mA DAC	LEMO	Allows using the REGUL8OR in a 4-20 mA control loop
Voltage Input	Isolated Banana	Two isolated banana connectors are installed to sense the external voltage on the load

Table 1: Short description of the connectors on the rear panel of the REGUL8OR

1.2.1 DCCT – Direct Current Transducer

To achieve high performance in terms of stability and low noise in the current readout and in the current regulation, the REGUL8OR takes advantage of the DCCT transducers of the  series manufactured by CAEN ELS.

The main characteristics of this technology are:

- Extreme low-noise values;
- Temperature Coefficient at sub-ppm level;
- Monitoring of DC and AC current;
- Galvanic isolation from the conductor to be measured – i.e. current can be measured at a high voltage potential.

The use of this technology greatly improves specifications respect to the most common requirements. The signal-conditioning network that converts the secondary current of the transducer to the voltage fed to the Analog to Digital Converter (ADC) is also a specific state-of-the-art know how.

Depending on the REGUL8OR model, the conversion of the secondary current into a voltage signal is performed either internally by a shunt network or directly by the external DCCT current transducers.

The REGUL8OR is factory-matched with a current-output DCCT, depending on the required output current, up to 1000 A.

Similarly, the REGUL8OR DCCT VOLTAGE model is factory-matched with a voltage-output DCCT, based on the required output current exceeding 1000 A and up to 3000 A.

1.2.2 Digital Control Loop

The core of the system is a fully digital PID controller that uses FPGA and DAC technologies to implement a control loop capable of maximizing the performance of any external power supply while adapting to varying load conditions.

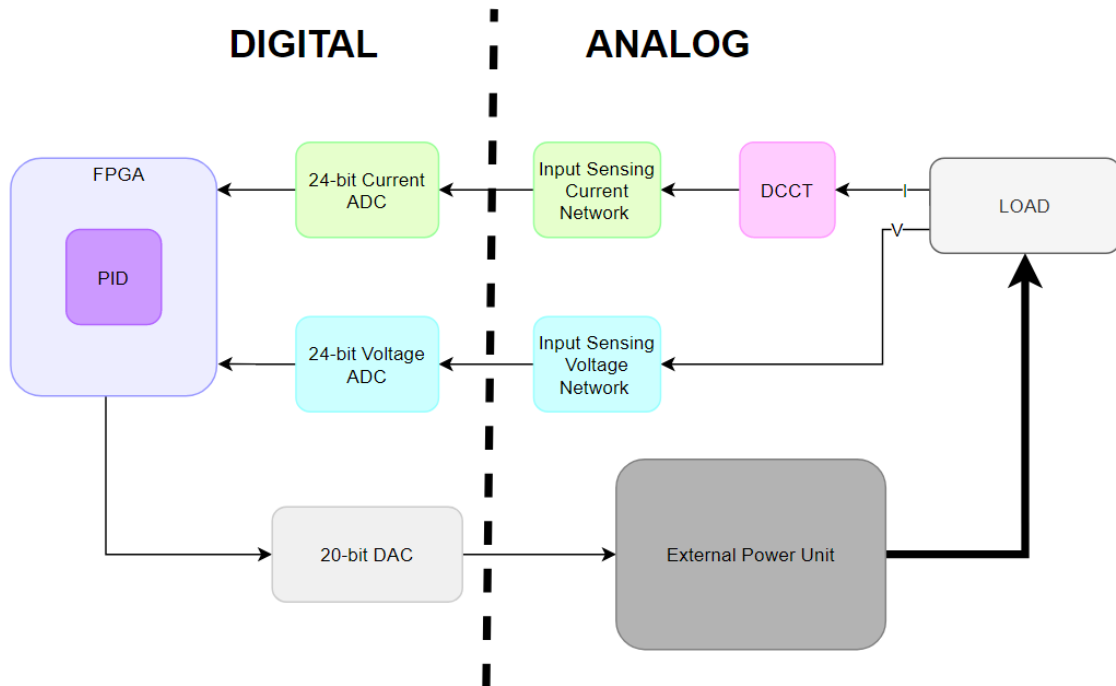

Figure 4: Schematic representation of the system

The implementation of the digital control loop via the REGUL8OR adds flexibility to any analog existing system, allowing it to be tuned to any load condition easily and remotely.

1.3 Operation Modes

The REGUL8OR system has multiple features and multiple configurations that allow using the unit for a very widespread scenario of applications and with a large variety of loads.

A brief summary of the basic configurations of the unit are hereafter presented.

1.3.1 Regulation Mode

The REGUL8OR can be used as current-controlled or voltage-controlled bipolar or monopolar unit. The regulation types are:

- **C.C.** mode: Constant Current (CC) regulation mode. The device regulates the output current produced by an external power supply and set by the user;
- **C.V.** mode: Constant Voltage (CV) regulation mode. The device regulates the output voltage produced by the external power supply and set by the user.

1.3.2 Control Mode

The REGUL8OR unit can be controlled in three main different ways that are hereafter listed:

- **LOCAL** control: the unit can be controlled directly via the front panel color display and the navigation switch. When the unit is set in LOCAL mode it is possible to perform readings and monitoring from the remote interface but setting commands are prohibited;
- **REMOTE** control: the unit is controlled via the TCP-IP Ethernet interface. The setting and control of the unit can be performed exclusively via this interface while monitoring is still possible from the local display;
- **FAST-INTERFACE** control: this interface allows controlling the unit via a proprietary protocol over the SFP/SFP+ interfaces (optical or electrical) and it is meant to be used for very fast applications. Update rates of more than 10 kHz can be achieved by using this communication channel.

1.3.3 Update Mode

The current or voltage setting of the unit can also be performed in four different modes:

- **NORMAL**: the update of the set-point (current or voltage, depending on the operation mode – i.e. CC or CV respectively) is performed as soon as a new set-point is received via the remote, local or fast interface
- **WAVEFORM**: the update of the set-point is performed on a specific timing (defined as a “waveform” attribute, more information on the *Waveform* section) and it is done internally
- **TRIGGER**: the set-point is updated by an external event – i.e. a hardware trigger coming from the rear BNC connector
- **ANALOG INPUT**: the unit is controlled by an external signal that is fed to the rear BNC connector. The unit acts as a C.C. or C.V. controller depending on the pre-set Regulation Mode

1.4 External Interlocks and Status Signals

The system is provided with 6 (six) external interlock inputs that can be easily configured using the Web Interface (embedded in the power unit) or directly using the standard power supply commands. A description of the configuration of the external interlocks using the power supply commands is hereafter described.

The REGUL8OR also features 6 (six) output status signals that are divided into:

- 2 (two) magnetic relays with the NO, NC and COMMON taps;
- 2 (two) solid state relays with two contacts;
- 2 (two) isolated TTL signals (0-5 V).

All of these signals can be connected with other internal signals or statuses (e.g. module ON, module OFF, all of the interlocks and so on) to create automations.

The configurability of the REGUL8OR series allows the users to decide which interlocks are enabled/disabled, to set the interlock “trip” level (i.e. low or high), the intervention time (i.e. the time that an interlock signal has to stay at the “trip” level before generating a fault condition) and to associate to each one an interlock name/identification.

This configuration can also be set and read using the Web Interface (provided with the power module) or using the low-level device configuration commands, which allows setting the advanced configuration parameters. All interlocks are disabled by default.

External Interlocks and Status Signals are available on a D-SUB 25-pin Female type on the rear panel of the REGUL8OR.

1.4.1 Interlock Enable/Disable Mask

The REGUL8OR series external interlocks can be enabled or disabled by writing in the corresponding Interlock Enable/Disable Mask field of the advanced configuration parameters. Refer to “Remote Control Manual” for additional details.

1.4.2 Interlock Activation Level Mask

Each external interlock can be chosen to trip at HIGH or LOW logic level. The dry-contact interlocks are hardware-activated when the input pins and their corresponding return pin are shorted. The remaining two interlocks are hardware-activated when there is no voltage between the input pins and their corresponding return pins. They are hardware-deactivated in case a 24-V voltage source is applied.

It is necessary to write on the advanced configuration parameters on the Web Interface or via standard power supply commands in order to configure the interlock state mask

1.4.3 Interlock Intervention Time

The module also allows to set the interlock intervention time (the time that an interlock signal needs to be at its activation level before tripping, thus generating a fault condition). The parameters of the Intervention Time (expressed in milliseconds) are stored in the device memory.

1.4.4 Interlock Isolation

The interlock pins are galvanically isolated from ground and output terminals, nevertheless the absolute maximum voltage, referred to ground, that these pins can sustain is of 54 VDC. All of the interlock inputs have their own return connection.

1.4.5 Output Status Signal – *User-Defined*

The solid-state relay signals (please refer to the I/O connector section for more information) can be remotely controlled by the user in order to change their states (open/shorted) for any specific customer application.

Solid State Relay Terminals shall not float more than ± 54 VDC above/below chassis ground and their maximum current rating should never exceed 400 mA.

The Signal Status can be set by writing in the corresponding Signal Status Mask fields of the advanced configuration parameters (refer to the “Remote Control Manual”) as well.

1.5 Trigger and Analog Control inputs

The standard version of the REGUL8OR includes inputs for a trigger signal and for an analog control on the rear panel.

A brief description of these features and their functionalities is presented hereafter.

1.5.1 Trigger input

The trigger input accepts TTL-compatible (5V) signals and should be driven by a low-impedance source or generator. The trigger input is galvanically isolated from ground and can float up to ± 54 VDC respect to the chassis.

The logic levels are subject to a hysteresis that allows for correct operation of the trigger feature even in noisy installations/environment. The trigger voltage logic levels are listed in **Table 2**:

Logic Level	Value
Low-to-HIGH	> 3.5 V
High-to-LOW	< 1.5 V

Table 2: Trigger Logic Levels

CAUTION

The absolute maximum rating for the Trigger Input signal is of **5.5 V** (a higher voltage level applied to this input can seriously damage the device).

A visual representation of the voltage levels for the trigger operation is presented in the following **Figure 5**

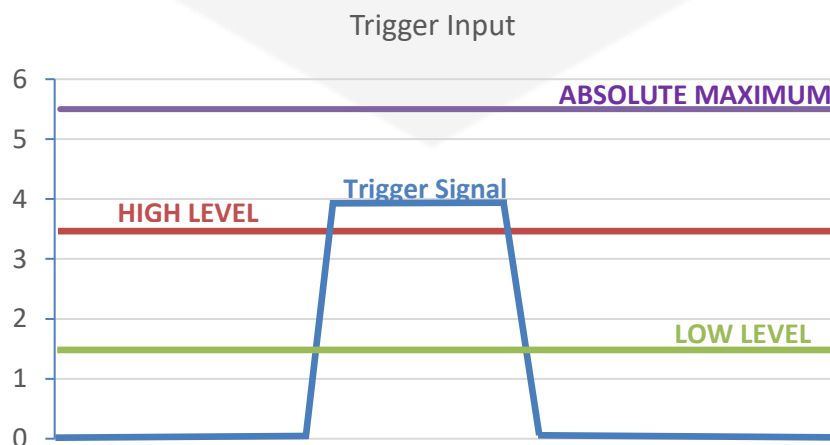

Figure 5: Trigger Thresholds

1.5.2 Analog Control Input

An input that allows the REGUL8OR to be controlled remotely with an analog signal is provided on the rear panel on an isolated BNC connector. This input is labelled as “AN. INPUT” and accepts signals ranging from -10 V to +10 V.

This isolated input acts as an input for a digital closed-loop amplifier and generates a control output signal (for the external unit) which is proportional to the input signal.

This means that the REGUL8OR will regulate the output at -100 % for a -10 V analog input voltage, a 0% for a 0 V analog input voltage and a +100 % for a +10 V analog input voltage.

An example of the link between the analog input signal and the output (can be either current or voltage, depending on the Regulation mode) is shown in **Figure 6**.

In order to avoid drift, offset and external noise pick-up it is always suggested to use the digital interface – e.g. Ethernet – to control the external power unit in order to get the best performance.

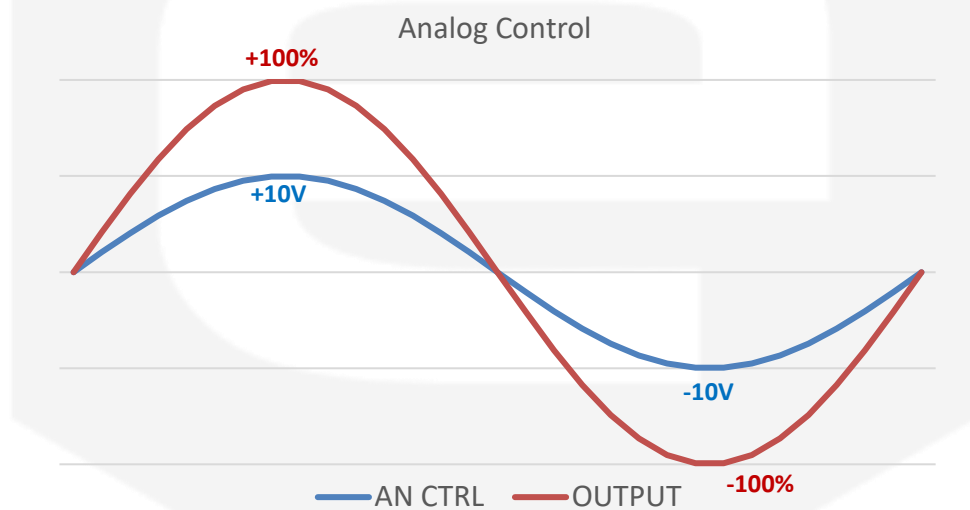

Figure 6: ANALOG CONTRL vs OUTPUT of the general-purpose power supply controlled

Please note that the bandwidth of the analog control input is internally limited to approximately 25 kHz.

1.6 External Sensors

The REGUL8OR is equipped with an input connector on the rear panel that allows users to connect different external sensors useful for sensing an external temperature or a magnetic field for example.

Having two different voltage supplies (1.8 V and 3.3 V referred to chassis ground) for the external temperature sensor allows installing a variety of different temperature sensors. The analog value is then conditioned by a low-pass filtering network that has a gain of $\frac{1}{2}$ and a cut-off frequency of 68-Hz. The analog signal is subsequently converted by a 12-bit ADC.

The REGUL8OR also includes an interface to supply and read an external Hall probe. Some Hall probes need to be supplied by a constant-current source while others by a constant-voltage source: an internal relay selects the type of supply to be used to power-up the Hall probe with:

- a constant voltage of 5 V
OR
- a constant current of 20 mA.

This option can be configured via the Web Interface or via the corresponding dedicated configuration commands.

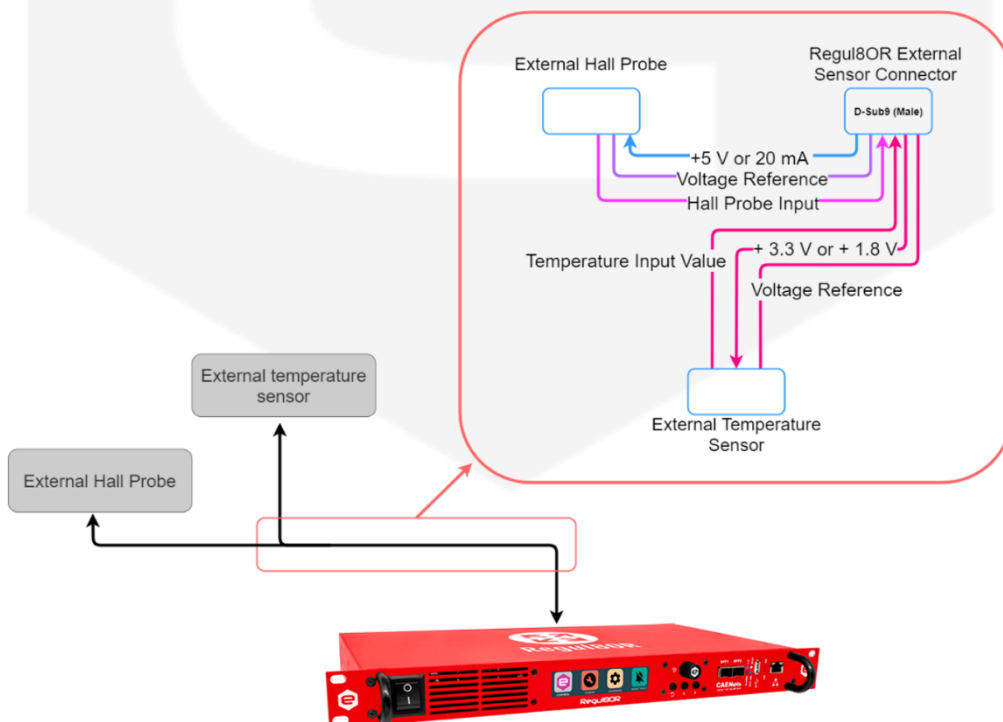

Figure 7: Schematic representation of the connection between the Regul8OR and an external temperature sensor and Hall Probe

1.7 Synchronization of Multiple Units

The SYNC IN and SYNC OUT SMA connectors (ground-referred) on the rear panel of the device allows connecting and synchronizing multiple REGUL8OR units, thus keeping two or more REGUL8OR units in-phase.

The first unit will generate an internal clock signal that will be fed to the SYNC OUT connector and needs to be connected to the SYNC IN input of the following unit.

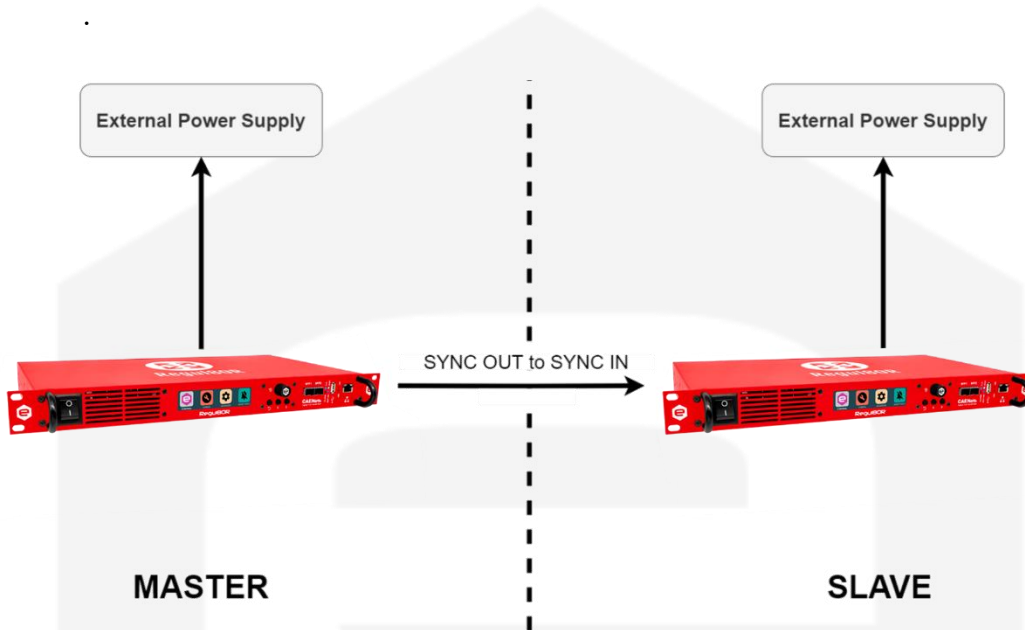

Figure 8: Schematic representation of a synchronization of multiple units

1.8 External SPI

An isolated SPI interface is present on the rear panel of the REGUL8OR on an 8-pin connector for interfacing external devices to the unit in order to match specific applications.

Pins for an isolated power supply rated a 2 W maximum are also present on the 8-pin connector. These voltage levels are isolated from chassis ground (they can float up to 54 VDC) and they are rated at 5 VDC with respect to the SPI ground pins.

As an example, it could be possible to custom-design a 32-channel temperature readout external module with a small microcontroller and this external module could directly be powered and read by connecting it to this SPI interface connector (all firmware and software would need to be developed).

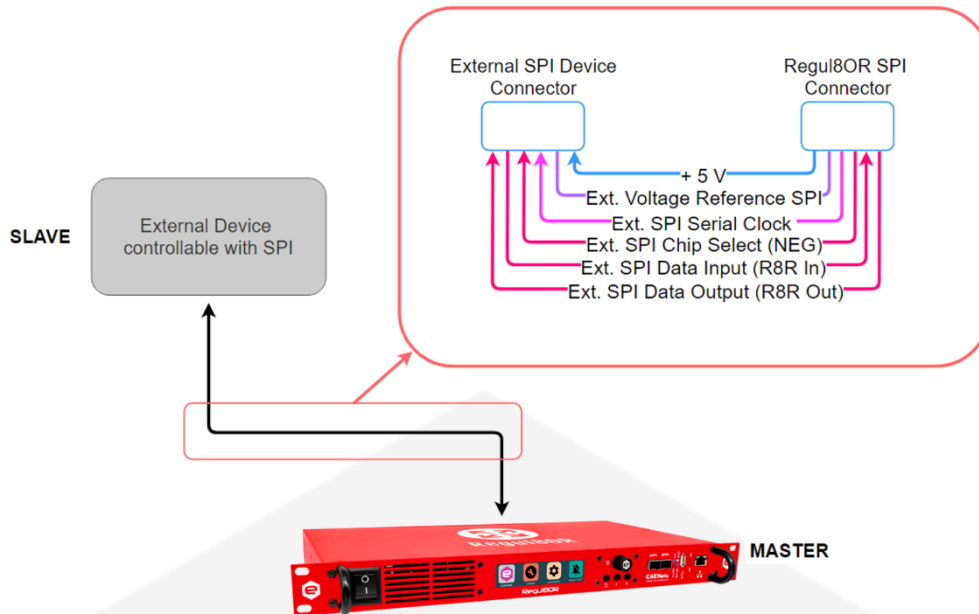

Figure 9: Schematic representation of a connection between the Regul8OR and a generic external SPI device

1.9 Output Connectors

The REGUL8OR has been designed to control an external power stage/programmable power supply with an analog output voltage or, in specific cases, an analog output current (to close a 4-20 mA loop).

Two connectors, an isolated BNC (voltage output) and a 4-pin LEMO (current path and voltage output), are provided on the rear panel to feed the isolated output signals.

Typically, a general-purpose programmable power supply can be controlled via an external analog voltage with typical values ranging from 0 V to 10 V or from 0 V to 5 V (unipolar operation). In some specific applications, these signals can range from -10 V to +10 V or from -5 V to +5 V (bipolar operation).

The analog output voltage is generated by a state-of-the-art 20-bit 1-MSPS Digital to Analog Converter (DAC).

The 4-20 mA current control loop is often used in industrial process control. Its name refers to the current range used to control or to measure in the loop, where the current spans from a minimum value of 4 mA (0 %) to a maximum value of 20 mA (100 % or full-scale). Current-based signals are less sensitive to noise than voltage signals and could be preferred in noisy environments – e.g. industrial facilities. The chosen loop driver is a single-channel, 16-bit converter.

1.10 Current connectors and Input Voltage

The output current and the output voltage are sensed by connectors placed on the device rear panel. The current is measured with a proprietary DCCT (as described in [sec. 1.2.1](#)) and connected to a DSUB9 female connector.

A single cable is required to connect the DCCT current-output version, and it is supplied with the REGUL8OR (**Figure 10 A**).

The DCCT voltage-output version requires a different cable for connecting the voltage output from the DCCT’s BNC and for powering the DCCT in addition to the DSUB9 male connector (**Figure 10 B**).

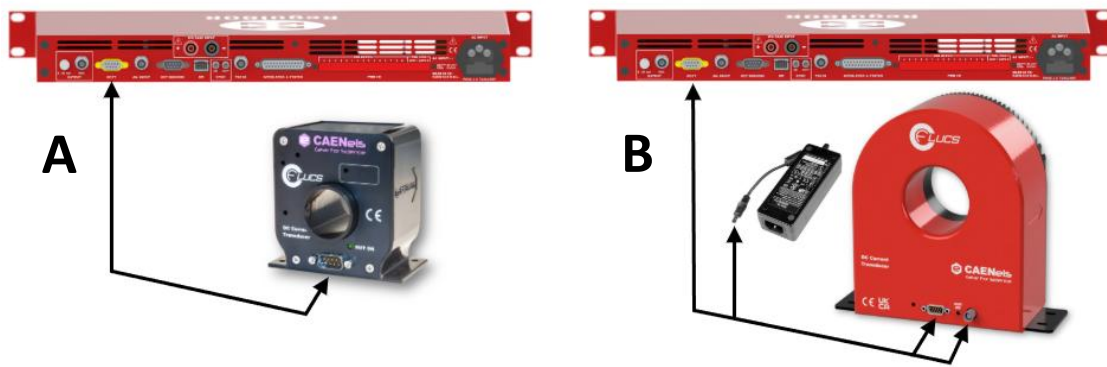

Figure 10: DCCT and REGUL8OR cable connection

The DCCT voltage-output version requires an external power supply. The rated supply voltage is 24 V and the accepted voltage range is [24 V ± 3%]:

V_{Min}	V_{Nom}	V_{Max}
23,3	24	24,7

The DCCT voltage output cable is supplied with the REGUL8OR DCCT VOLTAGE.

For any further information please refer to the CT-2000 and CT-3000 User’s Manual.

The voltage, on the other hand, is sensed using two isolated banana connectors.

Both current and voltage values are conditioned with two independent analog and digital networks that can be configured to read different ranges to optimize the regulation performance on several types of external power stages or programmable power supplies.

1.11 Front Panel Indicators

The REGUL8OR has four (4) front panel LED indicators as shown in the following **Figure 11**.

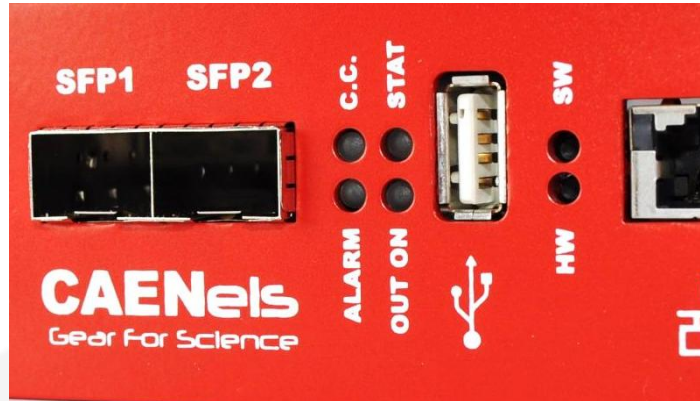

Figure 11: Front panel indicators

The front panel indicators and their behaviour are hereafter listed (clockwise starting from top-left):

- **C.C.:** Constant Current mode (**blue**). If turned on, the REGUL8OR is working in constant-current (CC) mode. When off, it is regulating in constant-voltage (CV) mode;
- **STAT (green):** indicates the correct operation of the module diagnostics. The blinking signaling (correct operation) has a 1-second period;
- **OUT ON (blue):** signals if the output is enabled or not. The blue LED is on if the output is enabled;
- **ALARM (red):** if turned on signals that the power unit has experienced a fault condition. It is necessary to perform a “reset fault” command in order to turn off this LED and to enable the output again (only if the fault condition/cause has been removed).

1.12 Internal Protections

The REGUL8OR is equipped with internal protections that allow configuring the unit for optimal operation, protecting both the unit and the connected load/external power unit/device from unwanted damages or undesired operating conditions.

A brief description of the REGUL8OR internal protections is hereafter presented with some more basic considerations on their operation and use.

1.12.1 Regulation Fault

This fault is generated when the power supply is not able to correctly regulate the output current or the output voltage (in C.C. and C.V. mode respectively).

Thresholds for the differential current, differential voltage and intervention time can be set by experienced users.

A typical example of a regulation fault is represented by a 10- Ω load on a general-purpose power supply rated at 300 A and 50 V where the maximum power supply output voltage is 50 V. By setting a current of 10 A to the load, the output voltage should reach a value of 100 V which obviously is not feasible: once the power unit supplies 5 A to the load it already reaches the maximum output voltage condition. The REGUL8OR digital controller recognizes this difference between the set-point – i.e. 10 A – and the actual output current, thus generating a “regulation fault” condition.

The tripping of this fault disables the output of the REGUL8OR unit and the general-purpose power supply (if there is the possibility to shut down the external unit with an external signal). A status reset – i.e. reset faults – needs to be performed in order to turn the unit back on.

1.12.2 OverTemperature - OVT

External monitoring of the temperature is performed by using an external temperature sensor connected to the External Sensor Connector (see Chapter 2.8). If the temperature reading is exceeding a pre-defined threshold, an OVT condition is generated.

The threshold value [$^{\circ}\text{C}$] can be set by experienced users. A reset fault operation needs to be executed on the status register of the REGUL8OR before turning the output off again.

1.13 Waveform

The REGUL8OR can also act as a waveform generator both in constant-current (CC) and in constant-voltage (CV) regulation modes.

The waveform is stored internally in a point-by-point scheme and the maximum number of points of the waveform can be defined as well as the sampling period (of the waveform execution).

The minimum time interval for the waveform execution period is rated at 0.1 ms = 100 μ s, giving an equivalent output waveform update rate of 10 kHz.

In order to correctly execute the output waveform, it is necessary to “tune” the PID regulator parameters of the entire system – i.e. REGUL8OR + external power supply – to the specific load.

More information on the waveform feature can be found in the corresponding command section.

2. Installation

This chapter contains the basic instructions for the initial inspection and preparation for use of the REGUL8OR.

2.1 Preparation for Use

In order to be operational, the REGUL8OR must be connected to an appropriate AC source. The AC source voltage should be within the device specifications. Do not apply power before reading, Section 2.2 and 2.4 Table 3 below, describes the basic setup procedure. Follow the instructions in Table 2.1 in the given sequence to prepare the power supply for use.

Step	Checklist	Description
1	Initial inspection	Physical inspection of the digital controller
2	Mounting	Installing the digital controller, ensuring proper ventilation
3	AC Input Power Connection	Connect the digital controller to the AC source
5	Power Supply connection	Connect the digital controller to the external power supply
4	First switch-on	Switch-on checkout procedure

Table 3: Installation checklist

2.2 Initial Inspection

Prior to shipment, this digital controller was inspected and found free of mechanical or electrical defects. Upon unpacking of the digital controller, inspect for any damage which may have occurred during shipping.

The inspection should confirm that there is no exterior damage to the digital controller such as broken switches or connectors and that all of the panels and display are not scratched or cracked. Keep all packing material until the inspection has been completed. If damage is detected, compile the RMA form available from the CAEN ELS website.

2.3 Mounting

The REGUL8OR module can be used either as a desktop unit or as a rack-mount device since the unit form factor is designed to be installed in a standard 19-inch cabinet (1U space occupation).

CAUTION

This unit is natural air-cooled; ventilation holes are present on the front and rear panel. Allow minimum 10 cm of unrestricted air space at the front and at the rear of the unit.

2.3.1 Rack Mounting

The REGUL8OR units are designed to fit in a standard 19” equipment rack.

CAUTION

Use mounting rails to provide adequate support for the unit.

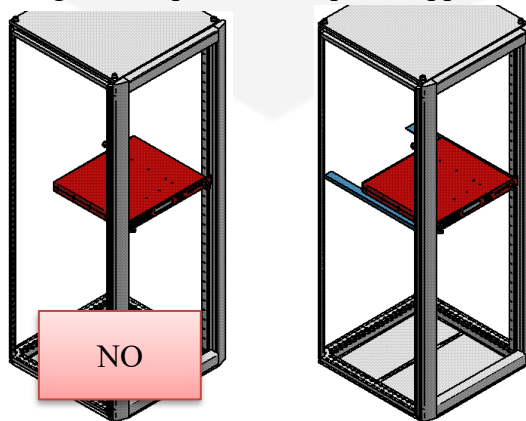

2.4 AC Input Power Connection

The AC line input connector on the rear panel is a standard IEC 60320 C20 male inlet socket. Mains fuse holders are located on the bottom part of the connector; required fuses characteristics for all the models are (**T2AL250V**):

- Size: 5 x 20 mm
- Current rating: **2 A**
- Blow characteristic: Time delay
- Breaking Capacity: **35 A**
- AC Voltage rating: **250 V**

2.4.1 AC Source Requirements

The REGUL8OR controllers are designed for universal AC input range since it can operate with voltage from 90 V to 240 V and input frequency ranging of 50 Hz or 60 Hz. Installation Category shall be **CAT II** so the maximum impulse voltage on the network mains must be below 2500 V.

2.4.2 AC Input Cord

All the REGUL8OR digital controllers are shipped with the corresponding power cord (suitable for the country of destination). The Power supply's side connector is a standard IEC 60320 C19 plug. Current rating for the connector is 2 A. Wire size for detachable power supply cord, not longer than 2 m, shall be at least 0.75 mm².



Figure 12: AC Power Line input socket

WARNING

There is a potential shock hazard if the power supply chassis is not connected to an electrical safety ground via the safety ground in the AC input connector!

2.5 External Power Supply Connection

WARNING

Turn off the AC input power (of both REGUL8OR and external power supply) before making or changing any rear panel connection. Ensure that all connections are securely tightened before applying power. There is a potential shock hazard when using a power supply with a rated output voltage greater than 60 V.

The REGUL8OR series needs a DCCT and an external power unit to work correctly. In the device shipping box all the cables necessary to connect the digital controller to the DCCT are included. If the REGUL8OR is bought together with the external power supply also all of the cables to the external device are included.

Table 4 describes the cables in the shipping box:

Cable	Description
DCCT	Cable for the connection of the DCCT current or voltage version to the REGUL8OR or REGUL8OR DCCT VOLTAGE, for DC output current reading
Voltage DAC	Connect the output analog signal to the power unit to control it [OPTIONAL]
Interlock and signal status	Necessary to read the external interlock and to apply the signal status to the external power unit. [OPTIONAL]
External Voltage	External voltage reading [OPTIONAL]

Table 4: Description of the cables in the shipping box

WARNING

Turn off the AC input power (of both REGUL8OR and external power supply) before setting or changing the DCCT. Set the digital controller (and the power unit) in OFF state to connect or disconnect the DAC control cable for the external power supply. Ensure that all connections are securely tightened before applying power.

2.6 Cable Length

In the table below - **Table 5** - the recommended length for the cables that will be connected to the device are listed.

Cable	Length
Output voltage DAC cable	< 3 m
Output current DAC cable	< 30 m
DCCT cable	< 3 m
Analog Input Cable	< 30 m
Input voltage cables	< 30 m
Sync In and Sync Out cable	< 3 m
Trigger Input cable	< 3 m
Opto-Transmitter	Not Applicable

Table 5: Recommended cable lengths

2.7 Interlock and Status Signals

The REGUL8OR module has four configurable dry-contact input interlocks, two 24-V interlocks, and six output status signals that are directly available on the D-Sub 25 Pin Female connector on the rear panel (**Figure 13**).

A mating connector, a standard D-SUB 25-Pin Male type, can be installed in order to use/access these available signals.

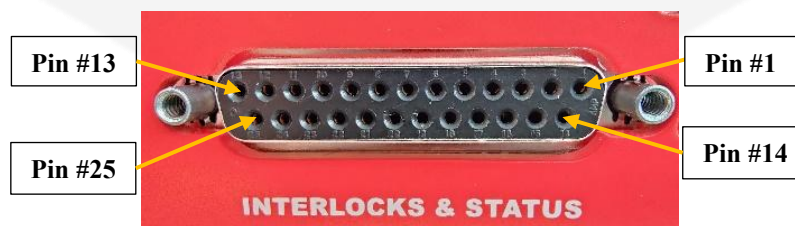

Figure 13: Interlock and Signal Status Connector

The pinout of the D-SUB 25 rear connector is summarized in the following table (Table 6):

Pin Number	Description
#1	TTL reference
#2	Magnetic Relay #1 Center Tap (CT)
#3	Magnetic Relay #2 Normally Closed (NC)
#4	Magnetic Relay #2 Normally Open (NO)
#5	Solid State Relay #1 - Terminal 2
#6	Solid State Relay #2 - Terminal 2
#7	Interlock #6 negative input
#8	Interlock #6 positive input
#9	Interlock #5 positive input
#10	Interlock #3 positive input
#11	Interlock #4 positive input
#12	Interlock #2 positive input
#13	Interlock #1 positive input
#14	Magnetic Relay #1 Normally Closed (NC)
#15	Magnetic Relay #1 Normally Open (NO)
#16	Magnetic Relay #2 Center Tap (CT)
#17	Solid State Relay #1 - Terminal 1
#18	Solid State Relay #2 - Terminal 1
#19	TTL Signal 2 – Output 5 V (Reference signal pin #1)
#20	TTL Signal 1 – Output 5 V (Reference signal pin #1)
#21	Interlock #5 negative input
#22	Interlock #3 negative input
#23	Interlock #4 negative input
#24	Interlock #2 negative input
#25	Interlock #1 negative input

Table 6: D-sub 25 Pin pin-out

WARNING

Magnetic Relay Contact (C-TAP, NO-TAP & NC-TAP) and Solid-State Relay Terminals (Terminal #1 & #2) shall not float more than ± 54 VDC above/below chassis ground. Interlocks input and return pins shall not float more than ± 54 VDC above/below chassis ground.

CAUTION

Voltage between relay C-TAP and NC-TAP or NO-TAP pins shall never exceed ± 54 V.
 Maximum current rating for the Magnetic Relays is 1 A; current through pins #CT and #NC or pins #CT and #NO shall never exceed 1 A.
 Maximum current rating for the Solid-State Relays is 400 mA; current through pins #Terminal1 and #Terminal2 shall never exceed 0.4 A.
 Do not apply voltage between any input interlock dry contact and its corresponding return.

The interlock pins are galvanically isolated from the chassis ground and outputs terminal, nevertheless the absolute maximum voltage, referred to chassis ground, that pins can sustain is 54V. The two interlocks inputs have their own return connection. The interlock is hardware-activated when the input pin and its corresponding return pin are shorted.

Relay	Pins	Maximum Current	Max Voltage (to chassis ground)	Max Voltage (between pins)
Magnetic #1	#14-2-15	1 A	54 V	54 V
Magnetic #2	#3-16-4	1 A	54 V	
Solid State #1	# 17-5	400 mA	54 V	48 V
Solid State #2	#18-6	400 mA	54 V	
TTL Signal #1	#19-1	10 mA (4 mA recommended)	54 V	5.5 V
TTL Signal #2	#20-1	10 mA (4 mA recommended)	54 V	5.5 V

Table 7: Ratings of magnetic and solid-state relays and for TTL signals

2.8 External Sensors

This connector (**Figure 14**) allows the user to connect external sensors to the REGUL8OR. Two pins are dedicated to supply an external voltage, one rated at 1.8 V and the other one rated at 3.3 V for a temperature sensor/transducer, one pin is dedicated to supply a 5-V voltage or a 20-mA current (can be selected via the Web Interface or via the relative configure commands for example for a Hall-probe), four chassis-ground (GND) pins and two pins for the input signals of the external sensors (one for a temperature sensor and one for Hall probe). The pinout of the D-SUB 9 rear connector is listed in **Table 8**

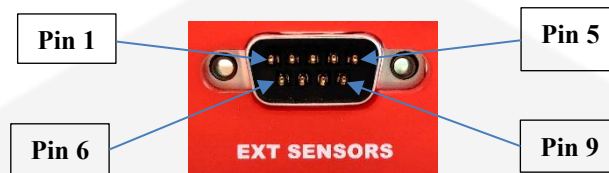

Figure 14: External Sensors input connector

Pin Number	Description
#1	Temperature voltage supply +1.8 V
#2	Temperature voltage supply +3.3 V
#3, #4, #7, #8	GND (chassis ground)
#5	Supply for a Hall-probe: Voltage source (5 V) or Current source (20 mA)
#6	External Input (Temperature Sensor 0 V/ +1.8 V)
#9	External Input (Hall Probe 0 V/ +5 V)

Table 8: External Sensors connector pinout

CAUTION

Do not apply voltage greater than + 1.8 V on pin 6, this can cause damages to the internal parts. (External Temperature Input pin).

Do not apply a voltage greater than + 5 V on pin 9, this can cause damages to the internal parts (External Hall Probe Input pin).

Do not apply any sources to pin 1, 2, 3, 4, 7, 8, 9: this can cause damages to the internal parts.

2.9 External SPI

To extend the possible applications of the REGUL8OR digital controller, an external module can be supplied and connected to the unit by using the isolated 8-pin SPI connector (**Figure 15**) on the rear panel. The pinout is described in the table below.

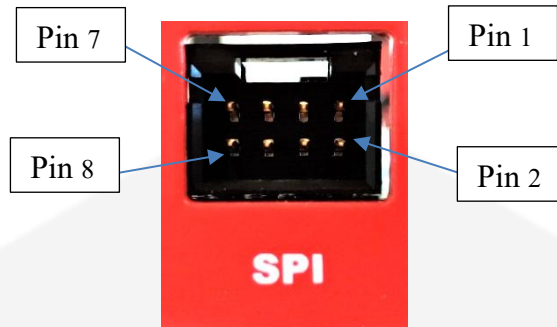

Figure 15: Isolated SPI connector

Pin Number	Description
#1, #7	External Voltage +5 V
#2, #8	Ext SPI reference
#3	Chip Select SPI (CS)
#4	Serial Clock SPI
#5	Data Output SPI
#6	Data Input SPI

Table 9: External SPI connector pinout

CAUTION

Every output signal is limited in a range of 0 V to + 5 V.

Do not apply a voltage input greater than + 5 V and lower than 0 V to Data Input pin (#6), this can cause damages to the internal parts.

2.10 Trigger and Analog Control Inputs

The isolated Analog Input connector can accept a voltage value in range of -10 V to +10 V and it can be used to control the REGUL8OR from an external voltage source in order to take advantage of the digital control loop. The isolated BNC connector is presented in the figure below (**Figure 16**).



Figure 16: Analog Input and Trigger connectors

The isolated Trigger Input (also on a BNC connector) can accept a voltage ranging from 0 V to +5 V and it can be used as a start/update signal for the REGUL8OR as explained in the dedicated sections.

CAUTION

Do not apply voltage greater than + 10 V (or lower than -10 V) on the analog input connector, this can cause damages to the internal parts.

Do not apply a voltage greater than + 5 V (or lower than 0 V) on the trigger input connector, this can cause damages to the internal parts.

2.11 Isolated Output Connectors

The control output of the REGUL8OR, one from the DAC and one from the 4-20 mA loop driver, is fed to the isolated output connectors as shown in **Figure 17**. These connectors are an isolated BNC for the DAC voltage output and a 4-pin LEMO that includes both the DAC (i.e. the same signal present on the BNC connector) and the 4-20 mA loop driver.

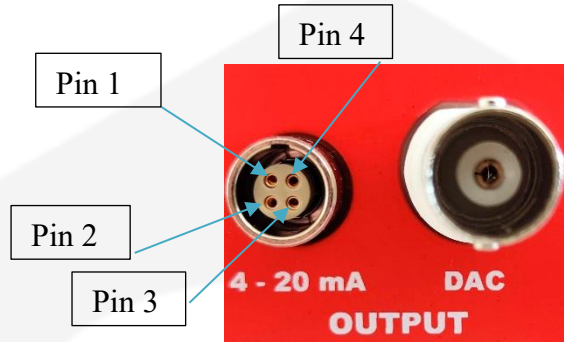

Figure 17: 4-20 mA and voltage outputs

Pin Number	Description
#1	Current output (for the 4-20 mA loop)
#2	<u>DO NOT CONNECT</u>
#3	DACs output reference
#4	Output voltage DAC

Figure 18: Isolated LEMO connector pinout

Please note that the DAC voltage output has an output impedance of 10 Ω .

The maximum source/sink capability of the DAC output is rated at ± 25 mA.

CAUTION

Do not connect an external input supply to both OUTPUTS connectors because this can cause damages.

2.12 SYNC IN and SYNC OUT

Multiple REGUL8ORs can be synced and phase-locked by means of a clock signal. This signal will be generated from a “master” REGUL8OR device on the SYNC OUT connector and will then be connected to the SYNC IN connector of another REGUL8OR unit. The synchronization can be done either connecting a single SYNC OUT signal to multiple SYNC IN signals or, better, by connecting the SYNC OUT, SYNC IN in daisy-chain mode. These signals are present on two SMA connectors on the rear panel of the unit as shown in **Figure 19**.



Figure 19: SYNC IN and SYNC OUT connectors

The signal generated on the SYNC OUT connector is a serial clock signal with logic levels of 0 V and +3.3 V.

CAUTION

Do not connect an external input supply to both SYNC IN and OUT because this can cause damages.

PLEASE ONLY CONNECT THE SYNC OUT SIGNAL TO SYNC IN INPUTS ON IDENTICAL REGUL8ORs.

The signal input can be only a serial clock with a voltage input that span between 0 V and +3.3 V.

2.13 Current and Voltage Inputs

The technology used on the REGUL8OR allows selecting how the digital PID works. The internal digital controller can work in two different modes: in the first mode the controller only considers one value (e.g. current or voltage) to be regulated, while on the other mode takes into account both the current and the voltage values.

Because of this last mode of operation, it is extremely important for the device to have both the current and the voltage readback fed to it. As previously described, both the voltage and the current networks can be remotely configured to have different hardware input ranges.

The current readout is performed via the external DCCT transducer (to be purchased separately depending on the desired range) and its pinout is shown in **Table 10**. Please note that the REGUL8OR is shipped already with a suitable cable for connecting to the chosen external DCCT transducer.

Pin Number	Description	
	REGUL8OR	REGUL8OR DCCT VOLTAGE
#1	DCCT Neg (Current Return)	DCCT Neg (V_{sense-})
#2, #7	N.C.	
#3, #4	GND (Chassis Ground)	
#5	-15 V	
#6	DCCT Pos (Current Signal)	DCCT Pos (V_{sense+})
#8	DCCT Fault	
#9	+15 V	

Table 10: DCCT connector pinout

DCCT Type	Cable code	Description
Current Version	CABL-PCT0004	Cable DB9 Plug to DB9 Socket, 3 m, Custom for CT-BOX 200 to 1000
Voltage Version	CABL-PCT0007	Y-Cable DB9 Socket to DB9 Plug + BNC, 3 m, Custom for Regul8OR C1 - CT2000-V or CT3000-V

Table 11: DCCT cable types

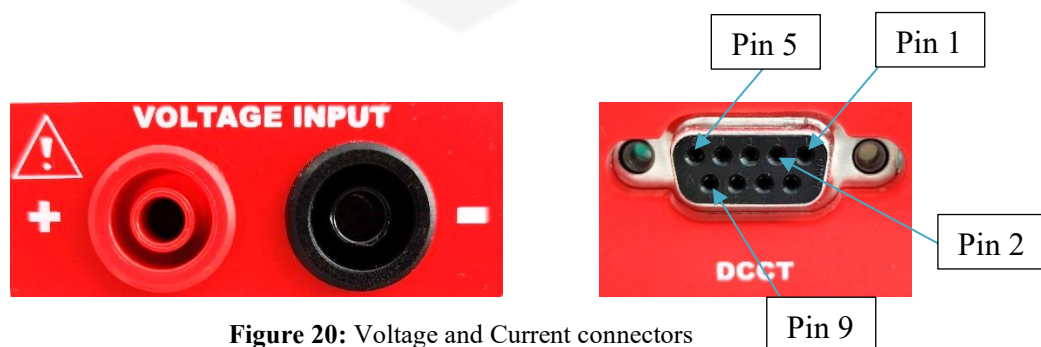

Figure 20: Voltage and Current connectors

WARNING

Use only CAT IV BANANA connectors.

Plug and unplug Banana connectors only if the external controlled power supply is completely switched OFF.

CAUTION

The REGUL8OR is shipped with a specific voltage and current ranges set. All the voltage ranges are calibrated while the current ranges are calibrated only for the purchased DCCT corresponding ranges (e.g. for a purchase with a 600-A DCCT, only the ± 600 A range is calibrated).

Do not exceed the rated values of both current and voltage because this can cause damages to the internal parts.

2.14 Insulation

A list of the insulation ratings of the different connectors, in accordance to the IEC Standard EVS-EN 61010-1:2010, are presented in the following table (**Table 12**):

Connector	Insulation Value
Voltage Input Connector	500 V
Current Input Connector	Not Insulated
Analog Input	500 V
Trigger Input	500 V
Isolated BNC Voltage Output	500 V
Isolated LEMO Current Output	500 V
Opto-Transmitter	Not Applicable
Interlock and Status Signal	500 V
SYNC In and SYNC Out	Not Insulated
External SPI	500 V
External Sensors	Not Insulated

Table 12: Insulation values for the connectors

2.15 Mating Connectors

The mating parts for the connectors present on the rear panel of the REGUL8OR are listed in **Table 13**. These parts are the recommended ones but equivalent ones can be used.

Connector	Recommended Mating Part
LEMO	FGG. 0B.304.CLAD52Z
BNCs (Trigger Input, Analog Input, Output voltage DAC)	Coaxial male connector
Input Voltage sheathed banana 4mm (72913)	Banana Plug Sheathed 4mm. CAT IV
Sync Out to Sync In	SMA
External SPI	IDC 8
D-SUB 25 (Interlock S.S.)	D-SUB 25 Male
D-SUB 9 (External Sensor)	D-SUB 9 Female

Table 13: Mating parts for the rear connectors

3. Local Control

This chapter describes the local control functionalities that are provided by the REGUL8OR and some useful information on how to use them.

The unit can work either in LOCAL mode or in REMOTE mode. The control mode (LOCAL or REMOTE) can be set in the configuration page of the local display. Please note that only readbacks are allowed from the remote communication interfaces when the unit is in LOCAL mode (i.e. no settings are allowed).

3.1 Navigation Buttons and Rotary Encoder Knob

Each REGUL8OR controller module is equipped with a knob and three push buttons on the front panel of the unit (see **Figure 21**) serving as navigation switch.



Figure 21: Encoder and pushbuttons for local control of the unit.

There are multiple actions that can be performed via this front navigation switch:

- Left, Right arrow pushbuttons to move among the items within the displayed page;
- Knob for encoder rotation;
- Back pushbutton to move at the previous page;
- Central pushbutton (referred to as “Enter”).

3.2 Display

The colour display on the REGUL8OR digital controller unit allows users to visualize information about the power supply status and to control the unit in order to use it locally. Screens and pages of the display can be navigated from the navigation switch through user friendly menus and sub-menus.

By default, the display will be automatically turned off after 30 minutes from the last local command or from the power on of the power supply.

The user can disable this feature or change the time value for the display power off; for more information, please refer to the “Remote Control Manual”.

3.2.1 Power-up

The REGUL8OR, upon power-up or power-cycling, will display an empty screen until the unit embedded OS is initialized.

Please note that this procedure will take approximately 25-seconds before the Home Screen is displayed.

3.2.2 Home Screen

The REGUL8OR home screen is the first loaded page upon power-up or power-cycling of the module, it is shown in **Figure 22**, and contains information on:

- the REGUL8OR model;
- the module IP address;
- output current readback value [A] with the light blue status bar;
- output voltage readback value [V] with the green status bar;
- the status of the output – i.e. ON or OFF;
- the status of the control – i.e. Local or Remote;
- the module Identification Name;
- the regulation mode of the unit – i.e. constant-current or constant-voltage.



Figure 22: Home Screen

The Home screen presents some indications on the right side as:

- **ON – OFF:** shows if the power supply output is enabled or not;
- **REM – LOC – FCI:** shows if the module is in Local, Remote or Fast Control Interface control mode;
- **C.C. – C.V.:** shows if the module is working in C.C. or in C.V. regulation mode.

An example of the indications on the right side of the home screen is hereafter shown in **Figure 23**:

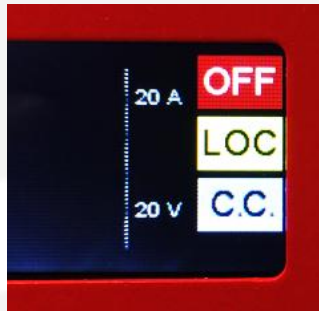

Figure 23: Home Screen indicators

If the module has experienced one or more faults – e.g. interlock intervention, over-temperature, etc. – the home page screen would display a list of the faults, turning also the module OFF.

The digital controller latches on every fault recognized by the internal logic so that every fault is recorded, thus providing the user with as much information as possible.

3.2.3 Menu Page

The Menu page is accessible by performing any action on the navigation switch when in the *Home Screen*.

The Menu Page gives access to all the local features of the REGUL8OR digital controller unit. There are four different options that can be selected as shown in **Figure 24**:

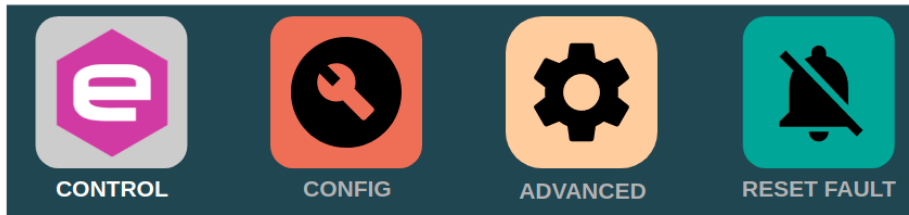

Figure 24: *Menu Page*

The accessible sub-pages and/or actions from this page are hereafter listed (note that the selected sub-menu appears in a lighter shade):

- **Control** – *sub-page*;
- **Config** – *sub-page*;
- **Advanced** – *sub-page*;
- **Reset faults** - *action*;

Each sub-menu can be accessed by navigating the menu with the encoder or the arrows and then pressing “Enter”.

The **Reset faults**, once pressed, resets the status register of the controller and sends back to the visualization of the *Home Screen*.

In order to **Return to the Main** screen, the back button in the control menu has to be pressed. In addition, the back button can be used to return to the previous screen in every menu or sub-menu.

3.2.3.1 *Control Page*

The *Control Page* is accessible by selecting the corresponding rectangle from the *Menu Page*.

The *Control Page* gives access to the main settings of the REGUL8OR controller unit. An example of a *Control Page* visualization is shown in **Figure 25**:



Figure 25: Control Page

From this screen it is possible to turn the power supply unit ON and OFF and to set the output current or voltage (depending on the regulation type, C.C. or C.V.).

Real values of output current/output voltage (readbacks) can also be seen in the page.

3.2.3.2 Config Page

The *Config Page* is accessible by selecting the corresponding rectangle from the *Menu Page*.

This page allows the user to set the control mode of the power supply – e.g. LOCAL or REMOTE – to select the regulation mode (C.C. or C.V.), to set the control mode (NORMAL or ANALOG INPUT) or to set the polarity of the polarity inverter (DIRECT or INVERS).

An example of a *Config Page* visualization is shown in **Figure 26**:

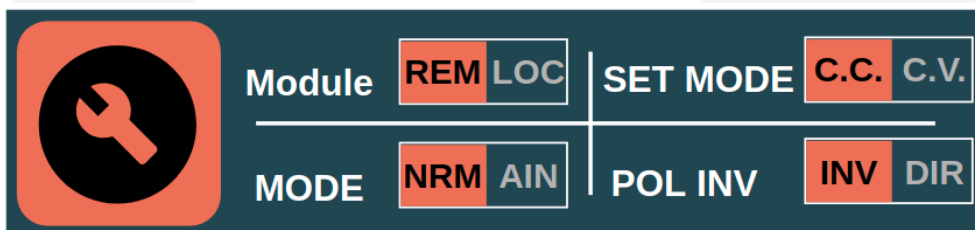

Figure 26: Config Page.

The firmware installed version is shown at the bottom of this page (FW Version).

3.2.3.3 Advanced Page

The *Advanced Page* is accessible by selecting the corresponding rectangle from the *Menu Page*.

This page allows to locally set the power supply Ethernet IP address, the Network Mas and the Gateway.

An example of an *Advanced Page* visualization is shown in **Figure 27**:

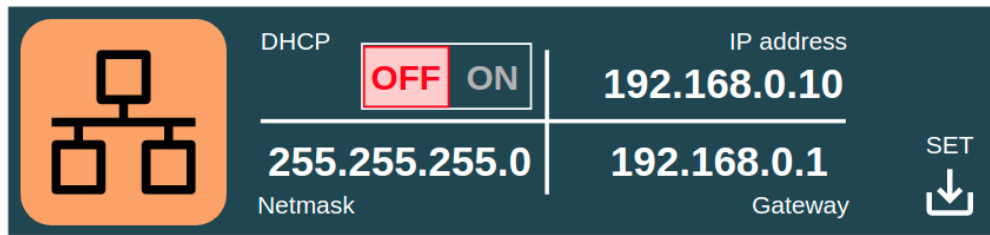

Figure 27: *Advanced Page – Network settings*

It is very important to notice that once the "SET" button has been clicked, the user can remotely communicate and get control of the power supply again only by opening a new TCP socket to the IP that has just been set.

4. Mechanical Dimensions

The mechanical dimensions of the REGUL8OR unit are hereafter presented in **Figure 28:**

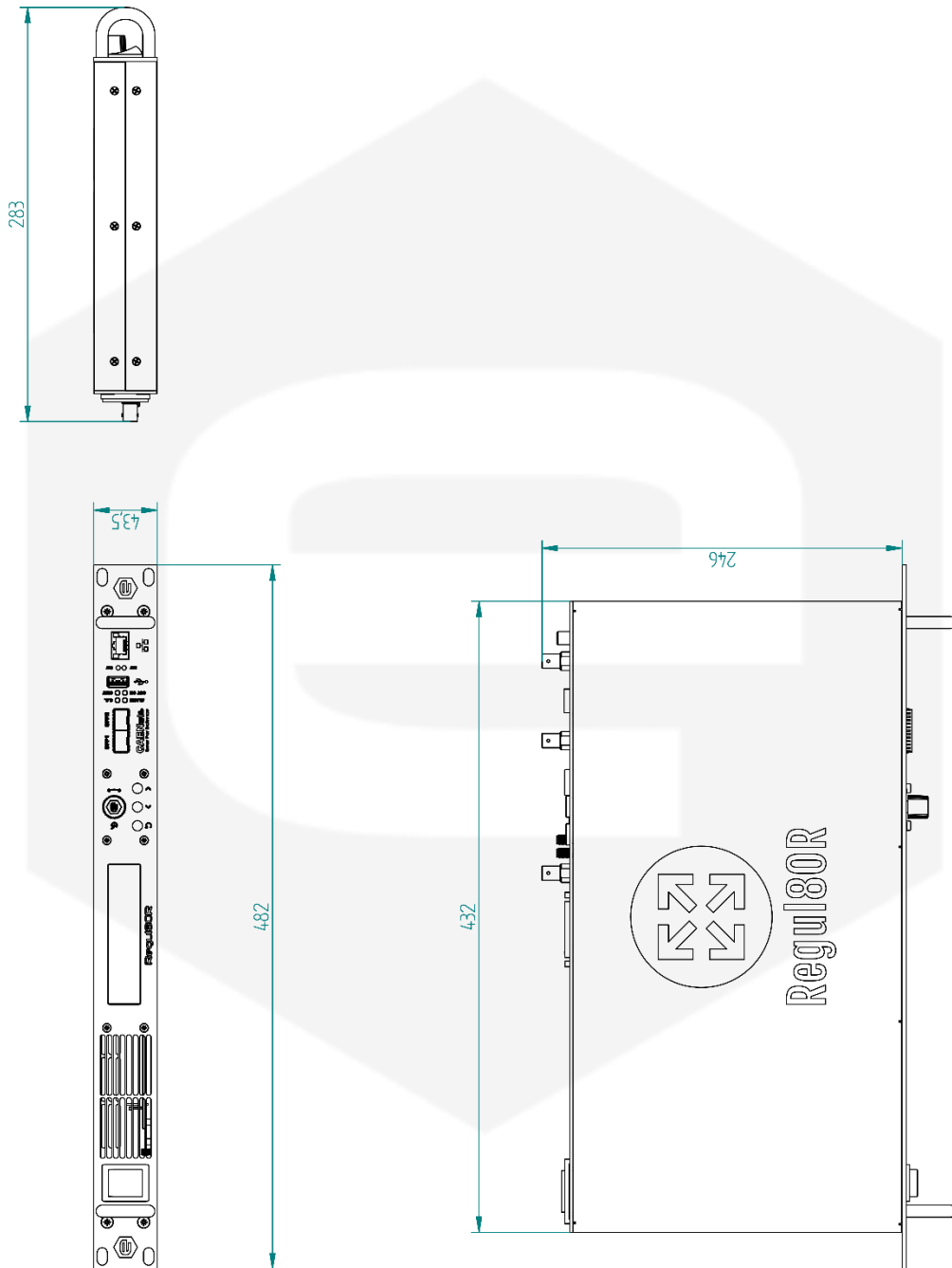

Figure 28: REGUL8OR Mechanical Drawings

5. Technical Specifications

Technical Specifications	REGUL8OR	REGUL8OR DCCT VOLTAGE
Input Current Range	±100 A, ±150 A, ±200 A, ±300 A, ±400 A, ±600 A, ±1000 A	±2000 A, ±3000 A
Input Voltage Range	±5 V, ±10 V, ±20 V, ±50 V, ±100 V, ±200 V	
Topology	Bipolar or Monopolar	
Control Mode	Constant Current (CC) and Constant Voltage (CV)	
Analog Control Input	Yes	
Current Setting Resolution	24 bit	
Voltage Setting Resolution	24 bit	
Output Readback Resolution	24 bit	
Analog Output Resolution	20 bit DAC – 23 bit DAC w/ dithering	
Temperature Coefficient	< 0.0002 % / K (CC mode) < 0.005 % / K (CV mode)	< 0.0003 % / K (CC mode) < 0.005 % / K (CV mode)
Long Term Stability (8 h)	< 0.001 % / K (CC mode) < 0.001 % / K (CV mode)	¹ TBD / K (CC mode) < 0.001 % / K (CV mode)
Accuracy RMS	< 0.01 % (CC mode) < 0.01 % (CV mode)	¹ TBD (CC mode) < 0.01 % (CV mode)
Control/Communication Interface	Ethernet TCP-IP SFP/SFP+	
Local Control	Color display with multi-function navigation switch	
External Signals	6x External Interlocks (4x dry contact and 2x 24 V) 6x Status signals – 2x magnetic, 2x solid-state, 2x TTL Trigger Input Analog Control Input External Sensors (Temperature and Hall probe) External SPI SYNC IN and SYNC OUT DCCT input	
Extra Features	Embedded Web-Server Waveform Execution Oscilloscope Remote Firmware Update Linux OS on-board	
Mechanical Dimensions (L×W×H)	19" x 1U x 283.5 mm (without connectors)	
Nominal Input Voltage	100-240 V _{AC} 50-60 Hz	
Input Voltage Range	90-264 V _{AC} 47-63 Hz	
Weight	< 2 kg	
Operating Temperature	0 ... 40 °C	

¹ to be defined

Table 14: Technical Specifications