



DC Current Transducers

CT-600

CT-1000



## User's Manual



All Rights Reserved  
© CAEN ELS s.r.l.  
Rev.3 – October 2025

PRECISION CURRENT TRANSDUCERS



**CAEN ELS s.r.l.**

Via Karl Ludwig Von Bruck 32– 34144 Trieste (TS)

Italy

Mail: [info@caenels.com](mailto:info@caenels.com)

Web: [www.caenels.com](http://www.caenels.com)



# Table Of Contents

<b>1. INTRODUCTION.....</b>	<b>9</b>
1.1  CURRENT TRANSDUCERS OVERVIEW .....	9
1.2 CT-600/CT-1000 MODELS AND VERSIONS .....	10
<b>2. INSTALLATION AND OPERATION .....</b>	<b>12</b>
2.1 MECHANICAL CONSIDERATIONS .....	12
2.2 CONNECTOR PINOUT .....	13
2.3 SECONDARY-SIDE SIGNALS .....	14
2.3.1 <i>Power Supply</i> .....	14
2.3.2 <i>Secondary Current (current versions only)</i> .....	14
2.3.3 <i>Voltage Output (“V” versions only)</i> .....	14
2.3.4 <i>STATUS Signal</i> .....	15
2.4 MOUNTING.....	17
2.5 PRIMARY CURRENT PATH .....	18
2.6 FULL-SCALE CURRENT .....	19
<b>3. ORDERING OPTIONS.....</b>	<b>20</b>
<b>4. TECHNICAL SPECIFICATIONS .....</b>	<b>21</b>
4.1 EQUIVALENT INPUT NOISE.....	22
4.2 INSULATION CHARACTERISTICS .....	24
4.3 EXTERNAL SHUNT RESISTOR .....	25
<b>5. MECHANICAL DIMENSIONS.....</b>	<b>26</b>

## Document Revisions

Revision	Date	Comment
1.0	September 16 <sup>th</sup> 2014	Document created
1.1	September 23 <sup>th</sup> 2014	Added power supply recommendation section
1.2	November 3 <sup>rd</sup> 2014	Manual graphics changed
1.3	January 27 <sup>th</sup> 2016	Table 3 updated
1.4	July 8 <sup>th</sup> 2016	Added data to technical specifications
1.5	November 18 <sup>th</sup> 2016	Document maintenance
1.6	March 12 <sup>th</sup> 2018	Added information on GNS connection
1.7	November 23 <sup>rd</sup> 2022	Added UKCA compliance logo. Fixed spaces in Flucs logo along the whole document.
2	August 8 <sup>th</sup> 2024	Updated address and revision numbering
3	October 15 <sup>th</sup> 2025	Added a note for correct grounding in the pinout configuration of the voltage version.

## PS1215 – Power Supply Recommendations

We strongly recommend using this product with the CAEN ELS PS1215 power supply, which has been especially designed in order to obtain low-noise operation and it is suited for DCCT measurement system where switching power supplies could corrupt measuring accuracy, precision and noise.

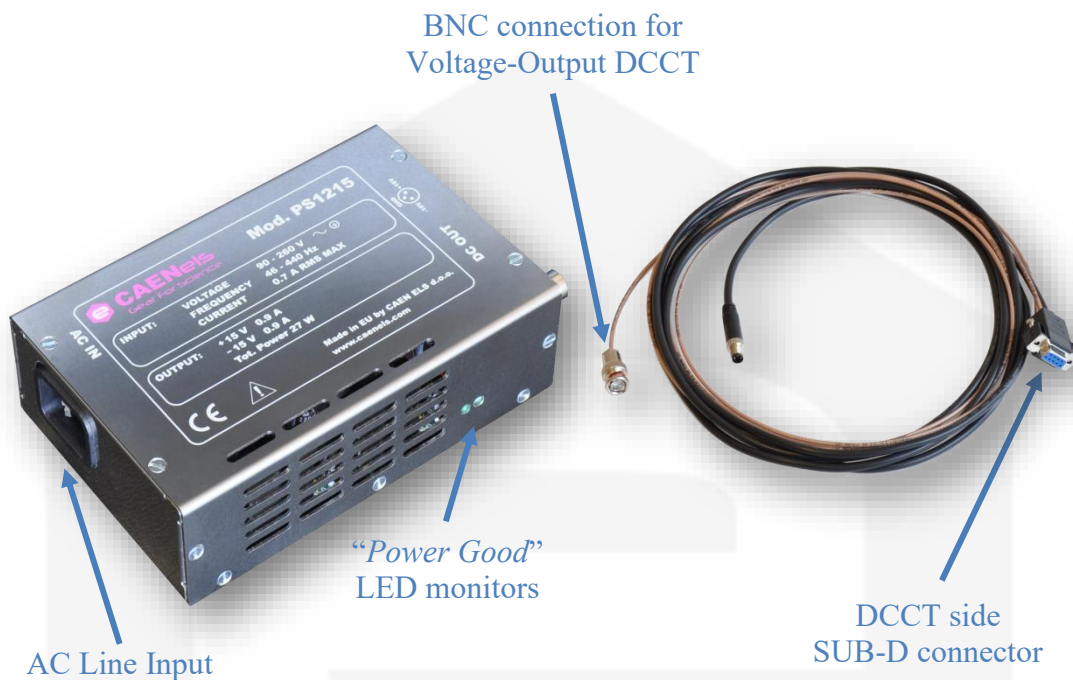

The power supply is available in two different versions, one to be used with the current-output DCCTs and one with the voltage-output ones (the PS1212V is shown in the previous image):

<i>Product Code</i>	<i>Description</i>
<b>WPS1215VXAAA</b>	<b>PS1215V</b> - AC/DC Single Output - Dual Voltage $\pm 15V$ Low Noise Power Supply - 27W max - 3m cable with DB-9 and BNC ( <u>Voltage</u> Output)
<b>WPS1215IXAAA</b>	<b>PS1215I</b> - AC/DC Single Output - Dual Voltage $\pm 15V$ Low Noise Power Supply - 27W max - 3m cable with DB-9 and banana plugs ( <u>Current</u> Output)

For more information or further details please refer to the PS1215 User's Manual.

## Safety information - Warnings

CAEN ELS will repair or replace any product within the guarantee period if the Guarantor declares that the product is defective due to workmanship or materials and has not been caused by mishandling, negligence on behalf of the User, accident or any abnormal conditions or operations.

**Please read carefully the manual before operating any part of the instrument**



### **Do NOT open the boxes**

**CAEN ELS d.o.o. declines all responsibility for damages or injuries caused by an improper use of the Modules due to negligence on behalf of the User. It is strongly recommended to read thoroughly this User's Manual before any kind of operation.**

CAEN ELS d.o.o. reserves the right to change partially or entirely the contents of this Manual at any time and without giving any notice.

### **Disposal of the Product**

The product must never be dumped in the Municipal Waste. Please check your local regulations for disposal of electronics products.



Read over the instruction manual carefully before using the instrument.  
The following precautions should be strictly observed before using the device:

---

**WARNING**

- Do not use this product in any manner not specified by the manufacturer. The protective features of this product may be impaired if it is used in a manner not specified in this manual.
- Do not use the device if it is damaged. Before you use the device, inspect the instrument for possible cracks or breaks before each use.
- Do not operate the device around explosives gas, vapor or dust.
- Always use the device with the cables provided.
- Turn off the device before establishing any connection.
- Do not operate the device with the cover removed or loosened.
- Do not install substitute parts or perform any unauthorized modification to the product.
- Return the product to the manufacturer for service and repair to ensure that safety features are maintained

---

**CAUTION**

- This instrument is designed for indoor use and in area with low condensation.

The following table shows the general environmental requirements for a correct operation of the instrument:

<b>Environmental Conditions</b>	<b>Requirements</b>
Operating Temperature	0°C to 50°C
Operating Humidity	30% to 85% RH (non-condensing)
Storage Temperature	-10°C to 60°C
Storage Humidity	5% to 90% RH (non-condensing)





# 1. Introduction

This chapter describes the general characteristics and main features of the  current transducers.

## 1.1 Current Transducers Overview

The  current transducers family is based on a closed loop technology that allows accurate and precise monitoring of DC and AC currents with high bandwidth.

Main characteristics of the entire  family are negligible temperature coefficient, excellent linearity and extremely low noise.

The transducers CT-Series family has a transform ratio between primary and secondary. The transform ratio value depends over the CT-Series model. External plastic casing guarantees galvanic isolation between the primary and the secondary circuits in order to allow to current measurements at a different potential and simplifies interfacing when using the , as the feedback element of current regulated power supplies. The internal conductive casing guarantees higher noise immunity and reduces undesired noise pick-up from external sources.

DC current transformers and transducers represent the ideal replacement for systems where Hall-effect sensors or shunt resistors are used as current sensing elements and better performances are needed.

Main application fields for these current transducers are precise and extremely stable regulated power supplies and power inverters.

Due to the excellent characteristics, the  transformers can be used in a variety of calibration, acceptance testing and quality control applications in the industrial and automotive fields.





## 1.2 CT-600/CT-1000 Models and Versions

The CT-600 and CT-1000 current transducers are available in two different versions that differ by the output type:

- standard secondary current output or
- buffered voltage output, where low temperature coefficient shunt resistor and low-noise amplifier are embedded in the internal electronics in the “V” model.

Connections for power supply and output signals are available through a standard D-SUB connector (also known as “DE-9”).

The different models and versions of the CT-600 and CT-1000 are summarized in the following table (Table 1):

<i>Product Code</i>	<i>Model</i>	<i>Description</i>
WCT600XAAAA	CT-600	600 A Primary Current  , Current-Output
WCT600VXAAAA	CT-600V	600 A Primary Current  , Voltage-Output
WCT1000XAAAA	CT-1000	1000 A Primary Current  , Current-Output
WCT1000VXAAA	CT-1000V	1000 A Primary Current  , Voltage-Output

**Table 1:** CT-600 and CT-1000 versions and models

The CT-Series transducer with the current output acts mainly as a transformer (with DC capability) that converts a full-scale bipolar primary current to a secondary current up to  $\pm 400$  mA. The voltage-output “V” version converts the primary bipolar full-scale current to a secondary output voltage of  $\pm 10$  V.

Front view of a CT-600/CT-1000 current transducer is presented in **Figure 1**.



**Figure 1:** front view of a CT-600 or CT-1000  current transducer

Rear view of the same current transducer, where self-threading holes for screws are visible, is presented in **Figure 2**.



**Figure 2:** rear view of a CT-600 or CT-1000  current transducer

## 2. Installation and Operation

General considerations and description of pinout and functionalities are herein presented.

### 2.1 Mechanical Considerations

Each version of the CT-Series current transducer presents an embossed “arrow” with the CAEN ELS logo on one side of the plastic casing that indicates the verse of the positive primary current measurement. This arrow can be seen in **Figure 3** on the right side of the enclosure.

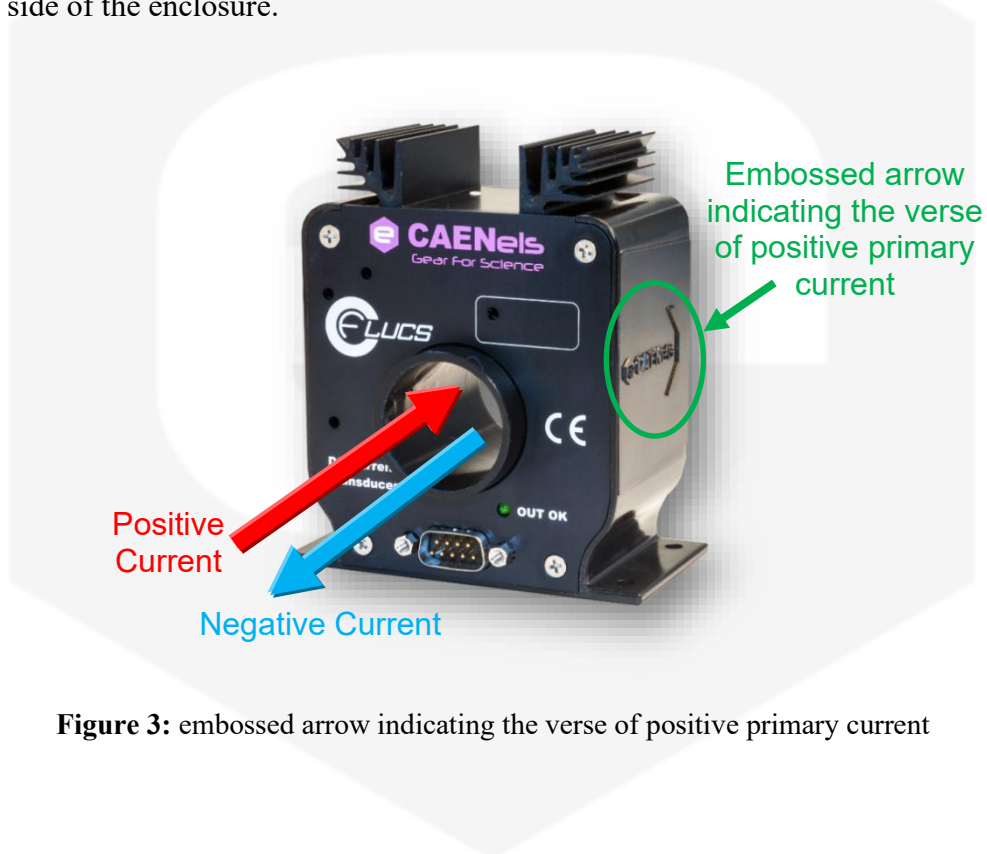

**Figure 3:** embossed arrow indicating the verse of positive primary current

## 2.2 Connector Pinout

The CT-600 and CT-1000 have a standard D-SUB 9-pin (or, commonly referred to as “DE-9”) in both their current output and voltage output versions. The standard pin numbering to refer to is herein presented in **Figure 4**.

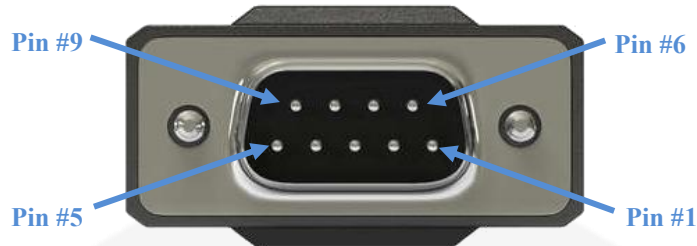

**Figure 4:** D-sub 9 connector pin numbering

The pinouts for the two versions are presented in **Table 2**. These two versions have current or voltage output pins (and their signal returns).

Pin #	CT-600 or CT-1000 (Current Output)	CT-600V or CT-1000V (Voltage Output)
1	I <sub>S</sub> return	nc - GND
2	nc	V <sub>OUT</sub>
3	Status -	
4	GND	
5	-15V	
6	I <sub>S</sub>	<b>Internal Use</b>
7	nc	V <sub>OUT</sub> return <b>Note 1</b>
8	Status +	
9	+15V	
<b>Note</b>	1: Vout return must be connected to GND close to the measurement point. Carefully refer to what is described in the paragraph 2.3.3.	

**Table 2:** CT-600 and CT-1000 pinout

Please note that pins not internally connected on the specific model are indicated in **Table 2** as *nc = not connected*. Please DO NOT connect any signal to the pins indicated as **Internal Use**. **Please note that, internally, I<sub>S</sub> is directly connected to GND.**

## 2.3 Secondary-side Signals

The signals on the “secondary” side of the CT-600 and CT-1000 current transducers are found on pins #1, 2, 3, 6, 7 and 8 (please note that not all of them are present on all versions) of the DE-9 connector.

### 2.3.1 Power Supply

Supply voltages for the CT-600 and CT-1000 have to be fed to pin #9 (+15V) and to pin #5 (-15V) of the D-sub 9-pin connector; both these voltages are referred to pin #4 (GND).

Maximum current that can be drawn from each one of these supply voltages is of 450 mA for CT-600 and 550mA for CT-1000 (a maximum of 50 mA for supplying the internal electronics circuits and a maximum of 400 mA for CT-600 or 500 mA for CT-1000 for the secondary current).

### 2.3.2 Secondary Current (current versions only)

On the “standard” current output versions the secondary current output  $I_s$ , scaled by its current transformation ratio is fed to pin #6. Current return pins are respectively found on pin #1 and on pin #7.

Maximum secondary current depends over the full-scale range and the current transformation ratio of the sensor. For example for a CT-1000 the full-scale range is  $\pm 1000$  A and its transformation ratio is 1:2000, thus its maximum secondary current is rated at  $\pm 500$  mA. An external shunt resistor, which can be placed close to the user's desired measuring circuit (to avoid the noise pick-up), is needed in order to convert the current signal to a voltage.

The voltage output pins ( $V_O$  and  $V_O$  RET) cannot be found on standard current output versions.

### 2.3.3 Voltage Output (“V” versions only)

A buffered output voltage signal is present on the voltage output versions of the transducers in order to allow easier connection of the DCCT to an external circuit or an Analog to Digital converter (ADC).

The full-scale output bipolar signal  $V_O$  (pin #2 for “V”-version) is referred to  $V_O$  RET (pin #7) and the behavior is as follows:

- +10V output if the primary current is equal to positive full scale of the sensor;
- -10V output if the primary current is equal to negative full scale of the sensor.

This behavior can be resumed in the gain parameter  $G$ , in [V/A], expressed as the ratio between the transducer output voltage ( $V_{Vo} - V_{VoRET}$ ) and the primary current  $I_P$ .

$$G = \frac{V_{Vo} - V_{VoRET}}{I_P}$$

**Vo RET** pin **is not** internally connected to ground GND (pin #4) and it should be connected to ground directly using a single-point connection (e.g. on an external ADC ground pins or  $V_{IN-}$  pin). The availability of this “return” signal is very useful in order to avoid additional ground-loops and noise pickup on the voltage-output version of the transducer.

Please note that the maximum differential voltage between the **Vo RET** and the **GND** pin has to be kept within  $\pm 0.5V$ .

$$|V_{VoRET} - V_{GND}| \leq 0.5 V$$

In the voltage output “V”-version of the transducers the current output pin  $I_S$  (pin #6) and its return (pin #1) are not present.

Please note that output impedance for the “V”-version models is  $50 \Omega$  and it is low-pass filtered with a  $0.5\text{-}\mu s$  time constant.

### 2.3.4 STATUS Signal

A STATUS signal, obtained from the outputs of an optocoupler phototransistor (**Status+** and **Status-**, pins #8 and #3) is present on all versions. Please note that the OK- signal is not internally connected to the ground potential and can be connected to an external reference potential. A green LED is also present on the front side of the DCCT indicating the correct operation of the devices.

A pull-up resistor is needed (between the OK+ and some supply voltage referred to the OK- potential) in order to correctly obtained the correct signaling.

Two examples on how to connect the OK+ and OK- signals are hereafter presented in **Figure 5** and in **Figure 6**.

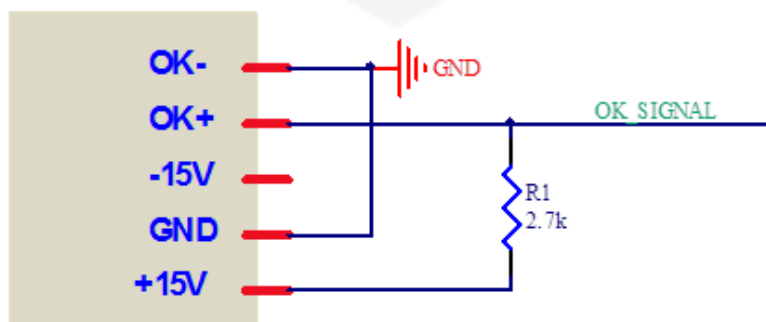

**Figure 5:** OUT OK signals connections using the +15V and the GND pins

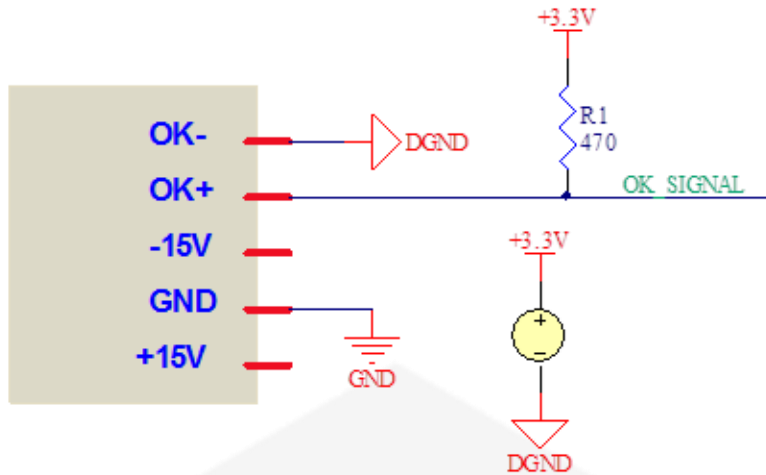

**Figure 6:** OUT OK signals connections as digital interfacing to +3.3V

Note that the connection scheme presented in **Figure 5** is referred to the GND potential and the OK\_SIGNAL is at low level (<0.4V) if the current transducer is correctly working while it is at high level (>14.5V) when the transducer is not.

In the configuration presented in **Figure 6**, the current transducer can be easily interfaced to a digital microcontroller, a Digital Signal Processor or an FPGA, supplied by a +3.3V voltage source.

Please note that the +3.3V supply and the OK\_SIGNAL is referred to DGND potential, which can be the same or different from the GND potential on which the transducer device is supplied from. The OK\_SIGNAL is found to be at low level (<0.4V) when the transducer is correctly working and at high-level (>3V) when not.



**Figure 7:** STATUS – OUT OK indications

The OUT OK green light is on, as shown in **Figure 7**, whenever the device is correctly working and regulating secondary output current – i.e. zero flux is established and secondary circuit is closed on the shunt resistor (external or internal in the “V” versions).

## 2.4 Mounting

The current transducers can be mounted in different configurations, depending on user's needs and opportunities, but heatsink shall never be faced to the floor.

The transducers are designed to be used in rack-mount applications, by means of any of the two (2) different 4-hole patterns placed in different sides of the mechanical case.

Four holes are present on the bottom of the device as indicated in the **Figure 8**.



**Figure 8:** bottom mounting holes pattern

Other four holes are present on the rear side of the plastic cover and can be used in order to fix the device by means of self-threading screws. These holes are indicated in **Figure 9**.

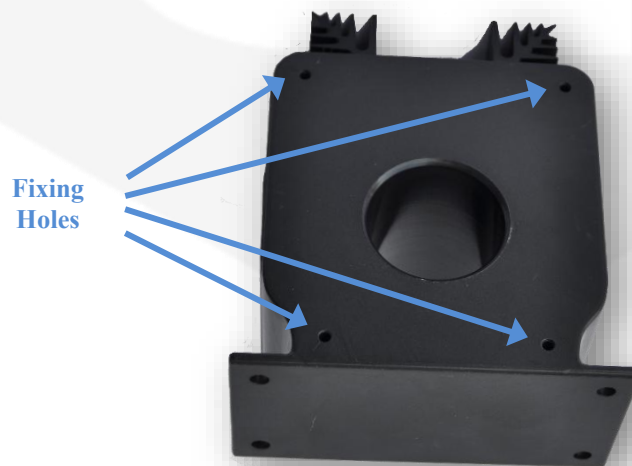

**Figure 9:** rear mounting holes for self-threading screws

The self-threading screws can have a maximum length of 15 mm (2.9 mm diameter) and the types that can be used are hereafter listed:

- UNI 8119
- DIN 7504 - P
- ISO 15482

## 2.5 Primary Current Path

A non-symmetrical layout of the primary current return path may degrade the accuracy and the noise of the current transducer. A cross section of the transducer plastic case illustrates what happens if the primary current is not equally distributed over the perimeter of the current transducer head.

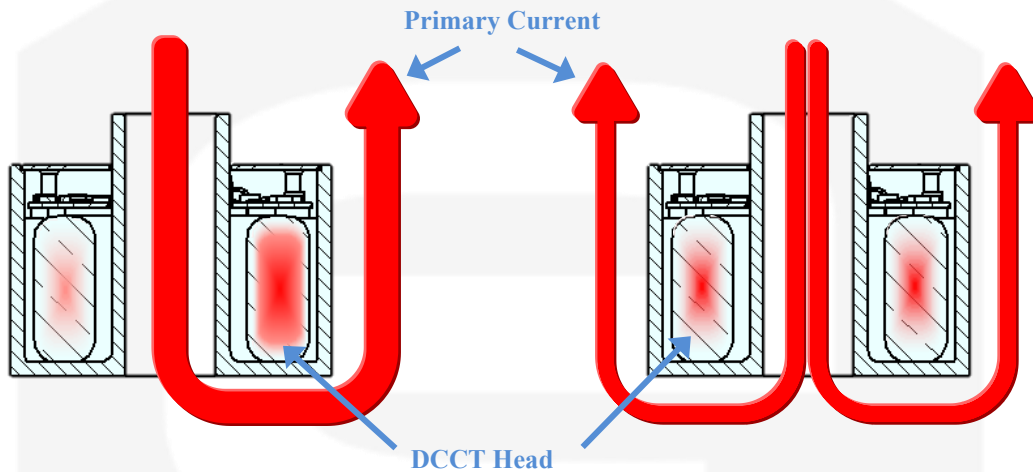

**Figure 10:** primary current path; non-recommended layout (left) and recommended layout (right)

**Figure 10** (left) shows what happens if the primary current is routed over one side of the DCCT head: the Magnetic flux density is higher in the area between the “U” path.

If the current path return is split in two or more paths over the DCCT Head, the magnetic flux density is more homogenous over the perimeter and the resulting measurement will be more accurate. If the split return path is not possible, it is preferable to keep the return cable as far as possible from the DCCT Head.

## 2.6 Full-Scale Current

Rated full-scale primary current can be easily changed by carrying out multiple turns on the primary conductor hole.

The full-scale current can then be scaled by a factor of  $N$ , with  $N$  = number of turns of the primary conductor around the hole. As an example (see figure **Figure 11**), a primary full-scale current of 600 A can be easily scaled by a factor 2 (applying two primary turns), and so the obtained full-scale will be 300 A or by a factor 3 (applying three turns) and so the obtained full-scale will be 200 A.

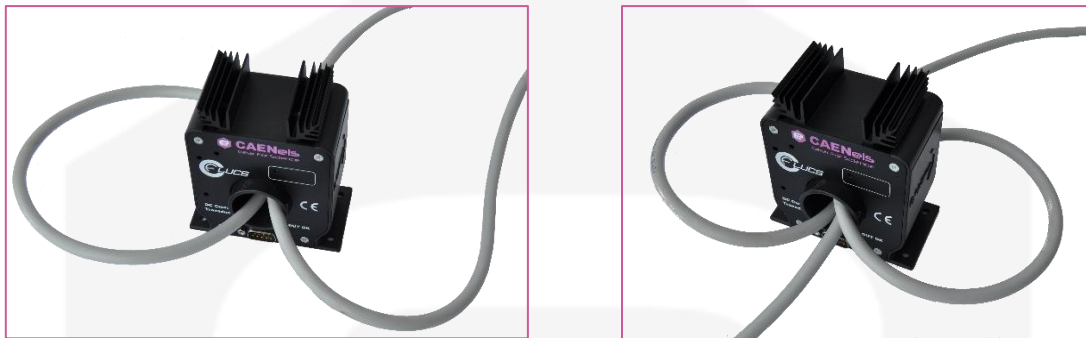

**Figure 11:** primary full-scale current scaled by a factor 2 (2 primary turns - left) and scaled by 3 (3 primary turns - right)

**Do not apply rated nominal full-scale primary current (for example 600A for CT-600) when carrying out multiple turns on primary conductor hole.**

### 3. Ordering Options

The **CT-600** current transducers have two different versions differing by the secondary output signal types. The ordering code is formatted as follows:

C	T	-	6	0	0	X
---	---	---	---	---	---	---

**Output Version**  
*empty* = current output  
**V** = voltage output

*NOTE: fields/characters shaded in grey color are fixed.*

The **CT-1000** current transducers have also two different versions differing by the secondary output signal types (current or voltage). The ordering code is formatted as follows:

C	T	-	1	0	0	0	X
---	---	---	---	---	---	---	---

**Output Version**  
*empty* = current output  
**V** = voltage output

*NOTE: fields/characters shaded in grey color are fixed.*



## 4. Technical Specifications

Technical Specifications for current transducers of the CT-600 and CT-1000 series are herein presented.

<b>Technical Specifications</b>	<b>CT-600</b>	<b>CT-1000</b>
Current Transformation Ratio - N	1:1500	1:2000
Maximum DC Primary Current - $I_{P(DC)}$	±600 A	±1000 A
Maximum RMS Primary Current - $I_{P(RMS)}$	424 A	708 A
Current Polarity	Bipolar	
Maximum DC Secondary Current - $I_{S(DC)}$	±400 mA	±500 mA
Maximum RMS Secondary Current - $I_{S(RMS)}$	283 mA	354 mA
External Shunt Resistor Value - $R_S$	0...5 Ω	0...2 Ω
Small Signal Bandwidth (±3 dB) - typ. BW	>150 kHz	
Equivalent Input Noise (@Bandwidth) *	< 1.5 ppm/FS @ 200Hz < 10 ppm/FS @ 50 kHz	
Output Voltage ("V"-version) - $V_{OUT}$	±10 V	
Output Voltage Gain ("V"-version) - $V_{OUT}/I_{P(DC)}$	1/60 V/A	1/100 V/A
Maximum Output Current ("V"-version)	±15 mA	
Temperature Coefficient - TC	< 0.5 ppm/°C typ. < 2 ppm/°C ("V"-version)	
Non-Linearity	< 5 ppm < 15 ppm ("V"-version)	
Induction into Primary (0-100 kHz) typ.	25 μV (RMS)	
Offset (with factory calibration) *	< 10 ppm/FS	
Protection Signal	OK Status	
Supply Voltage	±15 V ± 6%	15 V ± 3%
Current Consumption	50 mA + $I_S$	



<b>Secondary Coil Resistance - R<sub>SEC</sub></b>	<b>20 Ω</b>	<b>25 Ω</b>
<b>Accuracy (typ.) *</b>	<b>&lt; 30 ppm / FS &lt; 0.25% / FS ("V" - version)</b>	
<b>Connections</b>	<b>D-sub 9 connector</b>	
<b>Operating Temperature Range</b>	<b>0°C – 50°C</b>	
<b>Mechanical (Outer) Dimensions</b>	<b>107 x 91 x 50 mm</b>	
<b>Primary Conductor Hole Diameter - Ø</b>	<b>30 mm</b>	
<b>Maximum Weight</b>	<b>600 g</b>	

\* These specifications are guaranteed only when the CT sensor is used with the dedicated CAEN ELS PS1215 power supply

**Table 3:** Technical Specifications

## 4.1 Equivalent Input Noise

The typical equivalent input noise of the transducers is hereafter presented as a function of the measuring bandwidth and of the output version. The table and its graph are valid for both current and voltage output options.

<b>Bandwidth</b>	<b>CT-600 Equivalent Input Noise (ppm/FS)</b>	<b>CT-1000 Equivalent Input Noise (ppm/FS)</b>
<b>200 Hz</b>	<b>1.5</b>	<b>1.7</b>
<b>1 kHz</b>	<b>3.8</b>	<b>4.8</b>
<b>10 kHz</b>	<b>5.9</b>	<b>6.8</b>
<b>50 kHz</b>	<b>6.5</b>	<b>7.3</b>

**Table 4:** Equivalent Input Noise (typical values)

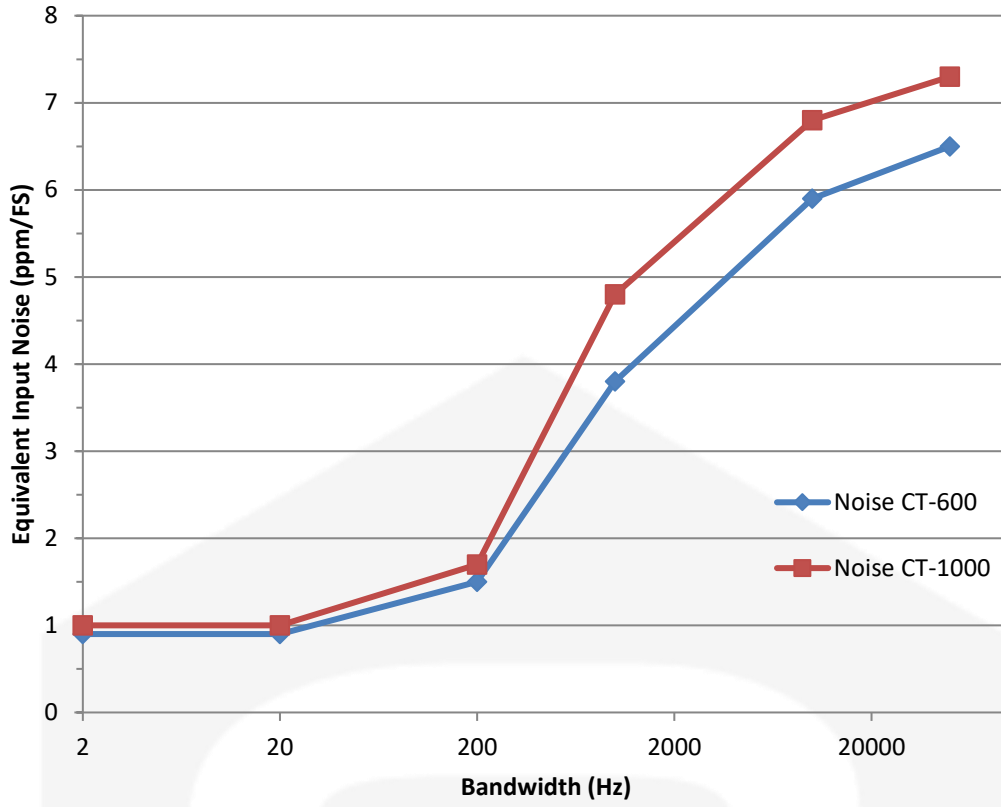

Figure 12: Equivalent input noise graph (typical values)

## 4.2 Insulation characteristics

In the following table are represented the insulation characteristics of the CT-600 and CT-1000 current transducers.

<i>Parameter</i>	<i>Value</i>	<i>Reference</i>
Rated insulation voltage (RMS), basic insulation	2000 V	IEC 61010-1 conditions - over voltage cat III - pollution degree 2
Rated insulation voltage (RMS), reinforced insulation	600 V	IEC 61010-1 conditions - over voltage cat III - pollution degree 2
Rated insulation voltage (RMS), basic insulation	1000 V	EN 50178 conditions - over voltage cat III - pollution degree 2
Rated insulation voltage (RMS), reinforced insulation	600 V	EN 50178 conditions - over voltage cat III - pollution degree 2
RMS voltage for AC insulation test, 50/60 Hz, 1 min	5.4 kV	Between primary and secondary + shield
Clearance (primary – secondary)	11 mm	Shorter distance path

**Table 5:** Insulation characteristics

The voltage insulation category could be improved, if insulated cable is used for the primary circuit.

### 4.3 External Shunt Resistor

The maximum value of the external shunt resistor that can be connected on the  $I_S$  output pin in the current-output versions is shown hereafter in the following charts.

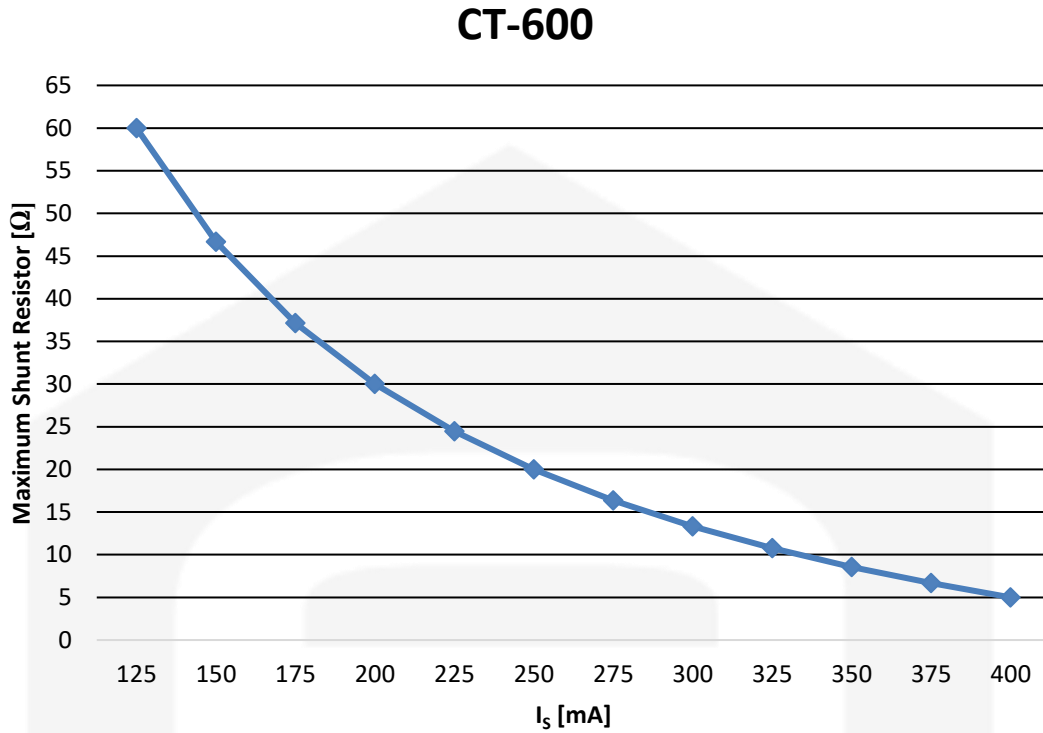

Figure 13: CT-600 maximum external shunt resistor (Current version only)

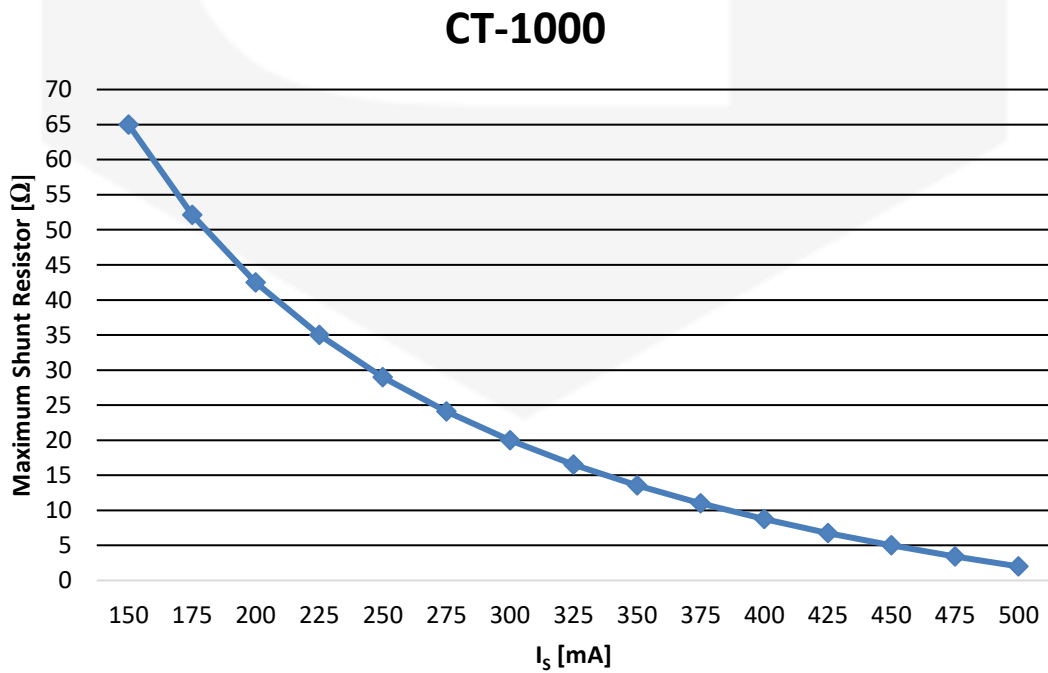
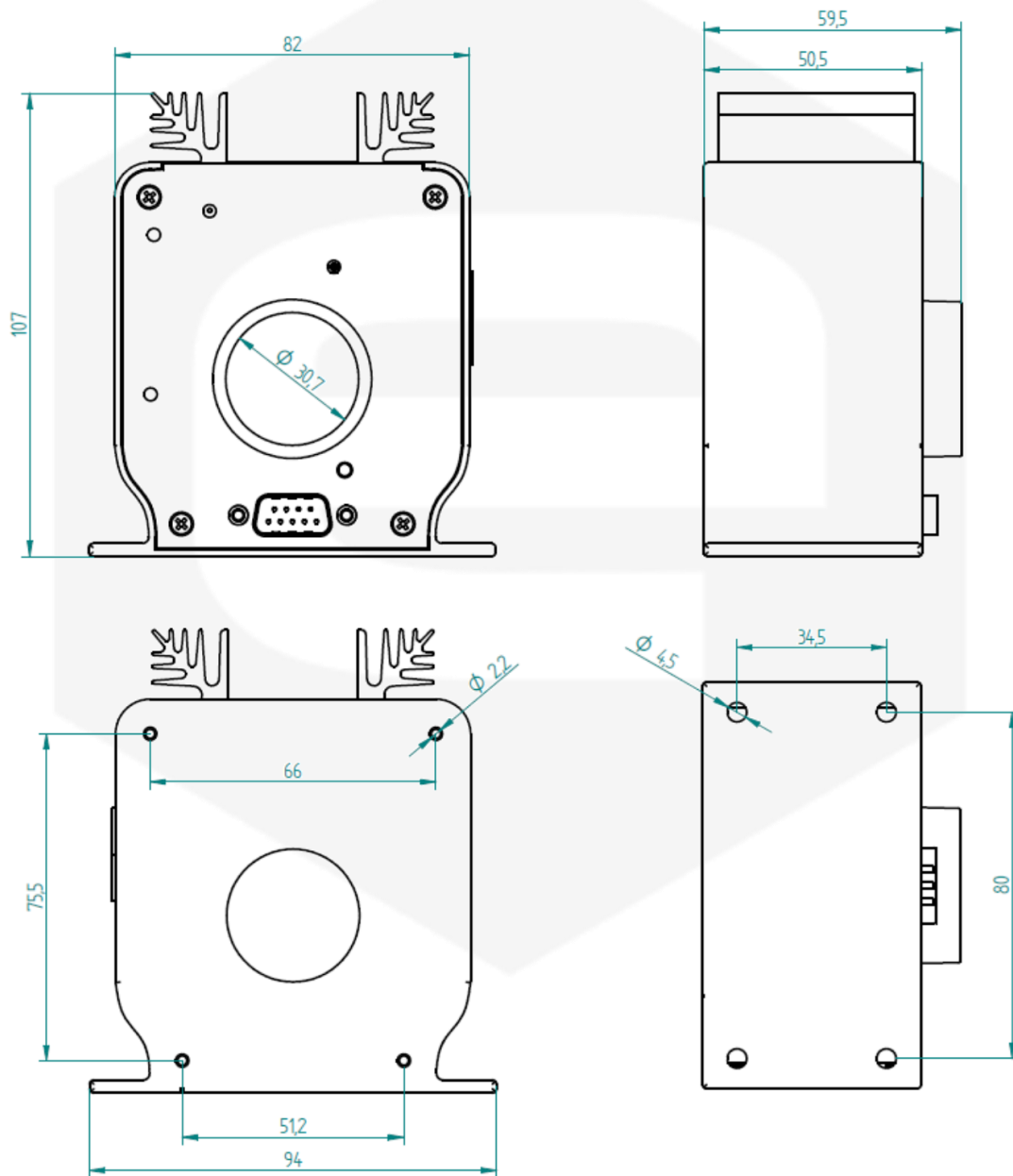

Figure 14: CT-1000 maximum external shunt resistor (Current version only)

## 5. Mechanical Dimensions

The mechanical dimensions of the CT-600 and CT-1000 case are hereafter presented (all dimensions are in **mm**).



**Figure 15:** Mechanical drawings