



DC Current Transducers

CT-100

CT-150



User's Manual



All Rights Reserved  
© CAEN ELS s.r.l.  
Rev. 3 – October 2025

PRECISION CURRENT TRANSDUCERS



**CAEN ELS s.r.l.**

Via Karl Ludwig Von Bruck 32– 34144 Trieste (TS)

Italy

Mail: [info@caenels.com](mailto:info@caenels.com)

Web: [www.caenels.com](http://www.caenels.com)

# Table Of Contents

<b>1. INTRODUCTION.....</b>	<b>9</b>
1.1 CT-100/CT-150 SERIES OVERVIEW .....	9
1.2 CT-100/CT-150 MODELS AND VERSIONS .....	11
<b>2. INSTALLATION AND OPERATION .....</b>	<b>12</b>
2.1 MECHANICAL CONSIDERATIONS .....	12
2.1.1 “C” - version and Pinout.....	13
2.1.2 “P” - version and Pinout.....	14
2.2 MOUNTING.....	15
2.3 PRIMARY CURRENT PATH .....	16
2.4 FULL-SCALE CURRENT .....	16
2.5 SECONDARY-SIDE SIGNALS.....	17
2.5.1 Power Supply .....	17
2.5.2 Secondary Current .....	18
2.5.3 Voltage Output (“V” versions only) .....	18
2.5.4 STATUS Signal.....	19
<b>3. ORDERING OPTIONS.....</b>	<b>21</b>
<b>4. TECHNICAL SPECIFICATIONS .....</b>	<b>22</b>
4.1 EQUIVALENT INPUT NOISE.....	23
4.2 EXTERNAL SHUNT RESISTOR .....	24
4.3 INSULATION CHARACTERISTICS .....	25
<b>5. MECHANICAL DIMENSIONS.....</b>	<b>26</b>
5.1 CT-100/CT-150 SERIES “C”-VERSION.....	26
5.2 CT-100/CT-150 “P”-VERSION .....	27

<b>Revision</b>	<b>Date</b>	<b>Comment</b>
1.0	June 9 <sup>th</sup> 2014	Document created
1.1	November 3 <sup>rd</sup> 2014	Manual graphics changed
1.2	February 24 <sup>th</sup> 2016	Updated external shunt values
1.3	July 8 <sup>th</sup> 2016	Added data to technical specifications
1.4	September 20 <sup>th</sup> 2017	Added insulation characteristics
1.5	March 12 <sup>th</sup> 2018	Added information on GND connection
1.6	March 27 <sup>th</sup> 2019	Layout modified
1.7	May 10 <sup>th</sup> 2019	Layout modified
1.8	November 23 <sup>rd</sup> 2022	Added UKCA compliance logo. Fixed spaces in Flucs logo along the whole document.
2	August 8 <sup>th</sup> 2024	Updated address and revision numbering
3	October 15 <sup>th</sup> 2025	Added a note for correct grounding in the pinout configuration of the voltage version.



## Safety information - Warnings

CAEN ELS will repair or replace any product within the guarantee period if the Guarantor declares that the product is defective due to workmanship or materials and has not been caused by mishandling, negligence on behalf of the User, accident or any abnormal conditions or operations.

**Please read carefully the manual before operating any part of the instrument**



### **Do NOT open the boxes**

**CAEN ELS d.o.o. declines all responsibility for damages or injuries caused by an improper use of the Modules due to negligence on behalf of the User. It is strongly recommended to read thoroughly this User's Manual before any kind of operation.**

CAEN ELS d.o.o. reserves the right to change partially or entirely the contents of this Manual at any time and without giving any notice.

### **Disposal of the Product**

The product must never be dumped in the Municipal Waste. Please check your local regulations for disposal of electronics products.



## PS1215 – Power Supply Recommendations

We strongly recommend using this product with the CAEN ELS PS1215 power supply, which has been especially designed in order to obtain low-noise operation and it is suited for DCCT measurement system where switching power supplies could corrupt measuring accuracy, precision and noise.

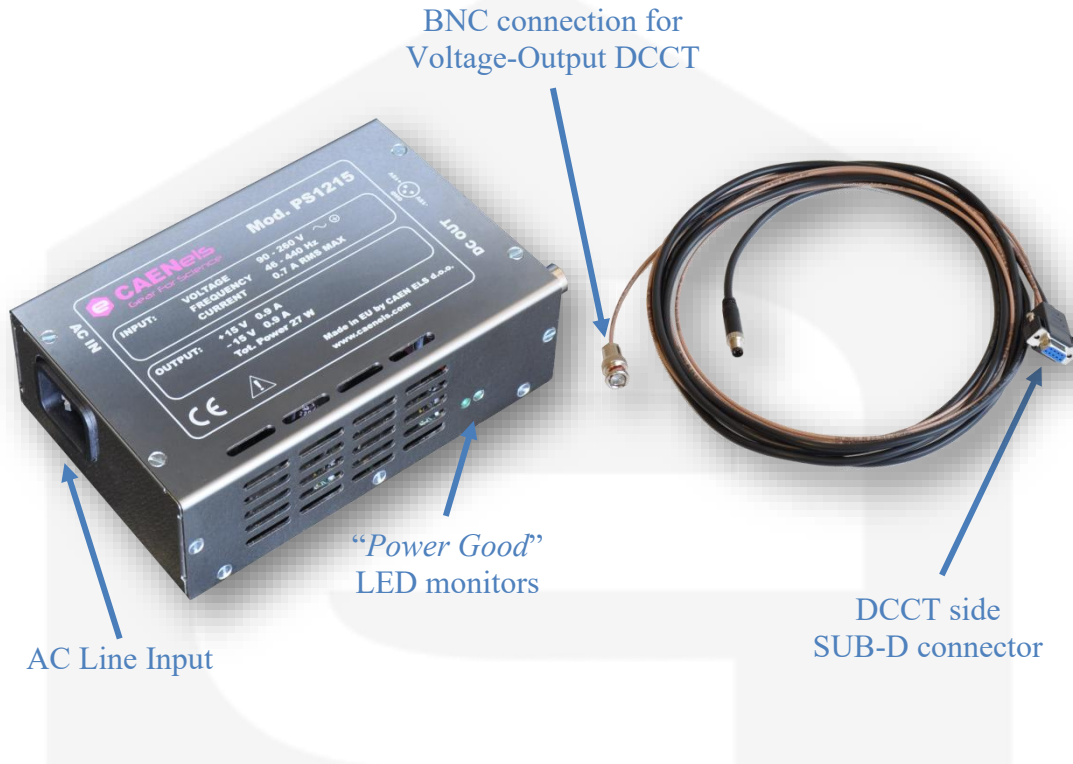

The power supply is available in two different versions, one to be used with the current-output DCCTs and one with the voltage-output ones (the PS1212V is shown in the previous image):

<b>Product Code</b>	<b>Description</b>
<b>WPS1215VXAAA</b>	<b>PS1215V</b> - AC/DC Single Output - Dual Voltage $\pm 15V$ Low Noise Power Supply - 27W max - 3m cable with DB-9 and BNC ( <u>Voltage</u> Output)
<b>WPS1215IXAAA</b>	<b>PS1215I</b> - AC/DC Single Output - Dual Voltage $\pm 15V$ Low Noise Power Supply - 27W max - 3m cable with DB-9 and banana plugs ( <u>Current</u> Output)

For more information or further details please refer to the PS1215 User's Manual.

Read over the instruction manual carefully before using the instrument.  
The following precautions should be strictly observed before using the CT-100/CT-150 DCCTs:

---

**WARNING**

- Do not use this product in any manner not specified by the manufacturer. The protective features of this product may be impaired if it is used in a manner not specified in this manual.
- Do not use the device if it is damaged. Before you use the device, inspect the instrument for possible cracks or breaks before each use.
- Do not operate the device around explosives gas, vapor or dust.
- Always use the device with the cables provided.
- Turn off the device before establishing any connection.
- Do not operate the device with the cover removed or loosened.
- Do not install substitute parts or perform any unauthorized modification to the product.
- Return the product to the manufacturer for service and repair to ensure that safety features are maintained

---

**CAUTION**

- This instrument is designed for indoor use and in area with low condensation.

The following table shows the general environmental requirements for a correct operation of the instrument:

<b>Environmental Conditions</b>	<b>Requirements</b>
Operating Temperature	0°C to 45°C
Operating Humidity	30% to 85% RH (non-condensing)
Storage Temperature	-10°C to 60°C
Storage Humidity	5% to 90% RH (non-condensing)



# 1. Introduction

This chapter describes the general characteristics and main features of the CT-100/CT-150 DC current transducer series .

## 1.1 CT-100/CT-150 Series Overview

The  (O-FLUX Current Sensor) family is based on a closed loop technology that allows accurate and precise monitoring of DC and AC currents with high bandwidth.

The internal conductive casing guarantees higher noise immunity and reduces undesired noise pick-up from external sources. The transducers CT-100/CT-150 family has a transform ratio of 1:1000 (CT-100) and 1:1500 (CT-150) between primary and secondary. External plastic casing guarantees galvanic isolation between the primary and the secondary circuits in order to allow to current measurements at a different potential and simplifies interfacing when using the , as the feedback element of current regulated power supplies.

Output from the CT-100/CT-150 transducers can be chosen between two different versions: standard secondary current output or buffered voltage output (low temperature coefficient shunt resistor and low-noise amplifier are embedded in the internal electronics in the “V” model). Connections for power supply and output signals are available in two different versions: the DB-9 connector (“C”-version) and a 7-pin through-hole strip (“P”-version).

Main characteristics of the entire  family are negligible temperature coefficient, excellent linearity and extremely low noise.

DC current transformers and transducers represent the ideal replacement for systems where Hall-effect sensors or shunt resistors are used as current sensing elements and better performances are needed.

The compact mechanical dimensions of this transducer series and its limited weight, as well as the DB-9 connector version, allow easy mounting on printed circuit boards with a Through Hole (TH) topology for the “P”-version and on racks for the “C”-version.

Main application fields for these current transducers are precise and extremely stable regulated power supplies and power inverters.

Due to the excellent characteristics, the O-FLUCS transformers can be used in a variety of calibration, acceptance testing and quality control applications in the industrial and automotive fields.

Front view of a CT-100/CT-150 current transducer in its DB-9 connector version is presented in **Figure 1**.



**Figure 1:** front view of a CT-100/CT-150  current transducer with DB-9 connector (“C”)

Rear view of the same current transducer, where self-threading holes for screws are visible, is presented in **Figure 2**.











**Figure 2:** rear view of a CT-100/CT-150  current transducer with DB-9 connector (“C”)

## 1.2 CT-100/CT-150 Models and Versions

The  current transducer series **CT-100/CT-150** is available in eight different versions that differ by the measurement range, the connectors and the output type – i.e. secondary current-output (standard) or secondary voltage-output (“V” version).

The different models and versions of the **CT-100/CT-150** series are summarized in the following table (**Table 1**):

<i>Product Code</i>	<i>Model</i>	<i>Description</i>
WCT100CXAAA	CT-100-C	100 A Primary Current  , DB-9 connector
WCT100PXAAA	CT-100-P	100 A Primary Current  , 7-pin PCB connector
WCT100VCXAAA	CT-100V-C	100 A Primary Current  , DB-9 connector, Voltage-Output
WCT100VPXAAA	CT-100V-P	100 A Primary Current  , 7-pin PCB connector, Voltage-Output
WCT150CXAAA	CT-150-C	150 A Primary Current  , DB-9 connector
WCT150PXAAA	CT-150-P	150 A Primary Current  , 7-pin PCB connector
WCT150VCXAAA	CT-150V-C	150 A Primary Current  , DB-9 connector, Voltage-Output
WCT150VPXAAA	CT-150V-P	150 A Primary Current  , 7-pin PCB connector, Voltage-Output

**Table 1:** CT-100/CT-150 series versions and models

The 7-pin “P”-type CT-100/CT-150 models are intended mainly for Printed Circuit Board mounting of the transducer. Mounting holes are present in all four versions of the device.

## 2. Installation and Operation

General considerations and description of pinout and functionalities are herein presented.

### 2.1 Mechanical Considerations

Each version of the CT-100/CT-150 current transducer presents an embossed “arrow” on the plastic part of the casing that indicates the verse of positive primary current measurement. This arrow can be seen in **Figure 3** (top view of a CT-100/CT-150 mechanical enclosure).

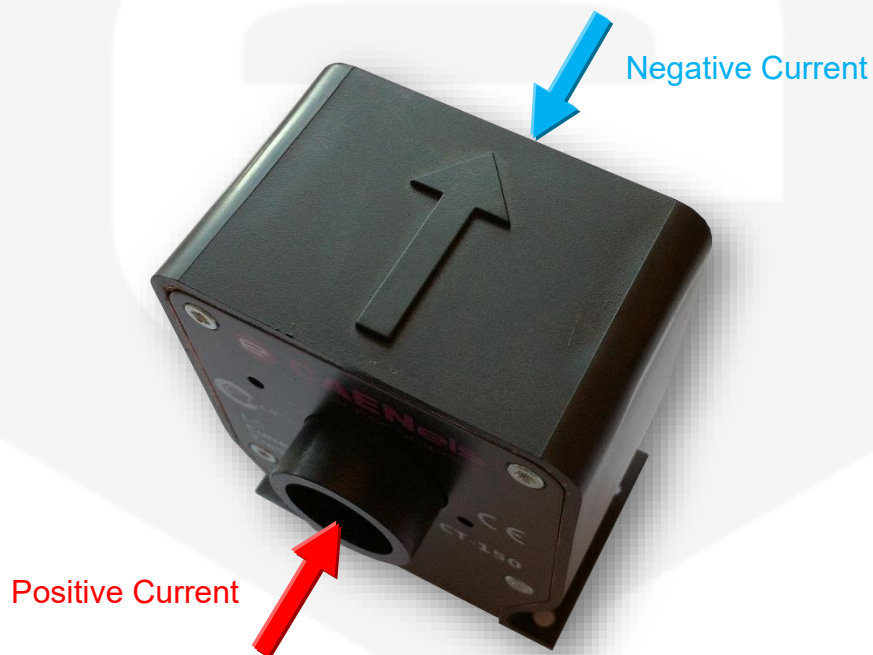

**Figure 3:** embossed arrow indicating the verse of positive primary current

The primary conductor hole diameter  $\varnothing$  in all models is rated at 16 mm (about 5/8”).

As presented in the previous section, two different models that differ by connector type are commercially available, as well as different versions (current- or voltage-output).

### 2.1.1 “C” - version and Pinout

The CT-100/CT-150 series “C” models have a standard D-sub 9-pin connector (i.e. “DE-9” or, commonly referred to as “DB-9”) in both their current output and voltage output versions. The standard pin numbering to refer to is herein presented in **Figure 4**.

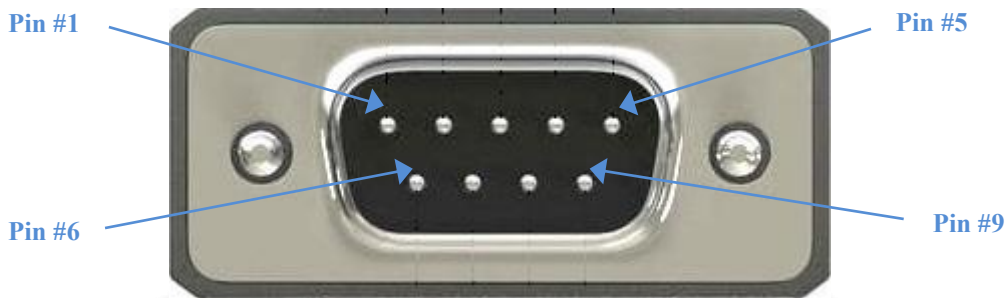

**Figure 4:** D-sub 9 connector pin numbering

The pinouts for the “C” versions are presented in **Table 2**. These two versions have current or voltage output pins (and their signal returns).

Pin #	CT-100-C or CT-150-C (Current Output)	CT-100V-C or CT-150V-C (Voltage Output)
1	I <sub>s</sub> return	nc - GND
2	nc	V <sub>OUT</sub>
3	Status -	
4	GND	
5	-15V	
6	I <sub>s</sub>	<b>Internal Use</b>
7	nc	V <sub>OUT</sub> return <small>Note 1</small>
8	Status +	
9	+15V	
<b>Note</b>	1: Vout return must be connected to GND close to the measurement point. Carefully refer to what is described in the paragraph 2.5.3.	

**Table 2:** CT-100/CT-150 “C” versions pinout

Please note that pins not internally connected on the specific model are indicated in **Table 2** as *nc* = *not connected*. Please **DO NOT** connect pins indicated as **Internal Use**. **Please note that, internally, I<sub>s</sub> is directly connected to GND.**

### 2.1.2 “P” - version and Pinout

The CT-100/CT-150 series “P” models have 7-pin through-hole connections in both their current output and voltage output versions. The standard pin numbering to refer to is herein presented in **Figure 5**.

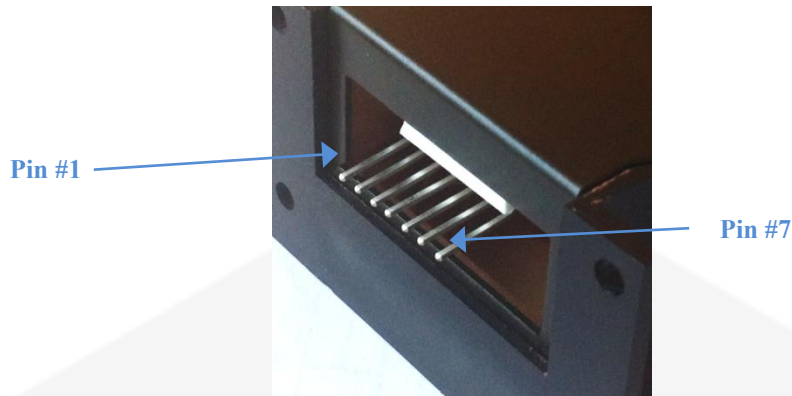

**Figure 5:** 7-pin Through Hole (TH) connections pin numbering

The pinouts for the “P” versions are presented in **Table 3**. These two versions have alternative current or voltage output signals (and their respective returns) on the same pins.

Pin #	CT-100-P or CT-150-P (Current Output)	CT-100V-P or CT-150V-P (Voltage Output)
1	GND	
2	-15V	
3	+15V	
4	Status +	
5	Status -	
6	I <sub>S</sub>	V <sub>OUT</sub>
7	I <sub>S</sub> return	V <sub>OUT</sub> return <b>Note 2</b>
<b>Note</b>	2: Vout return must be connected to GND close to the measurement point. Carefully refer to what is described in the paragraph 2.5.3.	

**Table 3:** CT-100/CT-150 “P” versions pinout

Please note that pins not internally connected on the specific model are indicated in **Table 3** as *nc = not connected*. **Please note that, internally, I<sub>S</sub> is directly connected to GND.**

## 2.2 Mounting

The CT-100/CT-150 series current transducers can be mounted in different configurations, depending on product models and versions.

The “C” versions are usually meant to be implied in rack-mount applications, by means of any of the two (2) different 4-hole patterns placed in different sides of the mechanical case.

Four holes are present on the bottom of the device as indicated in the following **Figure 6**.



**Figure 6:** Bottom mounting holes pattern

Other four holes are present on the rear side of the CT-100/CT-150 series current transducer plastic cover and can be used in order to fix the device by means of self-threading screws. These holes are indicated in **Figure 7**.

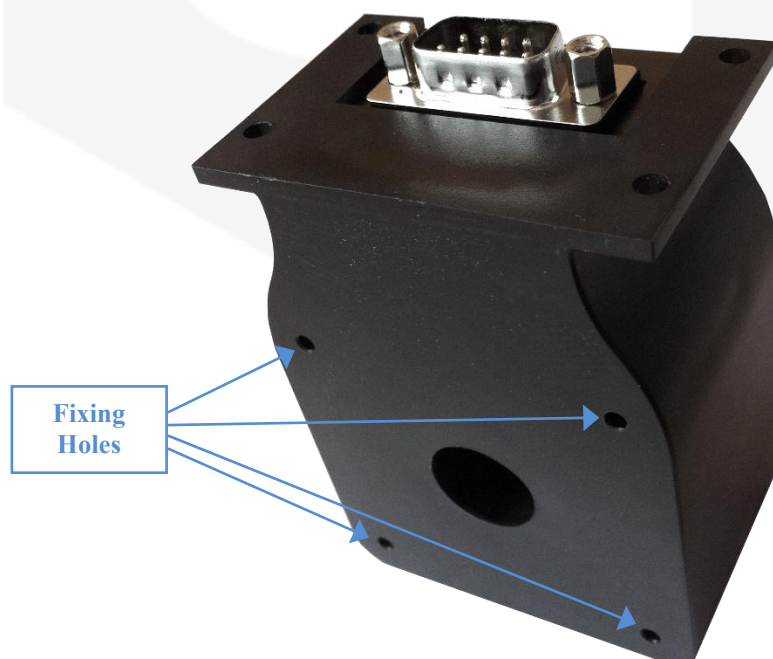

**Figure 7:** Rear mounting holes for self-threading screws

The self-threading screws can have a maximum length of 15 mm, diameter of 2.9 mm, and the types that can be used are hereafter listed:

- UNI 8119
- DIN 7504 - P
- ISO 15482

## 2.3 Primary Current Path

A non-symmetrical layout of the primary current return path may degrade the accuracy and the noise of the current transducer. A cross section of the transducer plastic case illustrates what happens if the primary current is not equally distributed over the perimeter of the current transducer head.

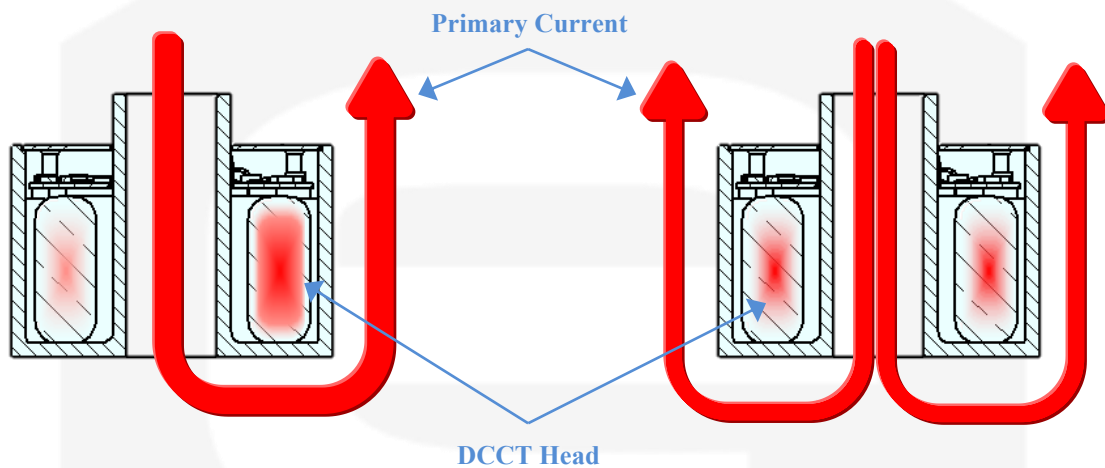

**Figure 8:** Primary current path; non-recommended layout (left) and recommended layout (right)

**Figure 8** (left) shows what happens if the primary current is routed over one side of the DCCT head: the Magnetic flux density is higher in the area between the “U” path.

If the current path return is split in two or more paths over the DCCT Head, the magnetic flux density is more homogenous over the perimeter and the resulting measurement will be more accurate. If the split return path is not possible, it is preferable to keep the retuning cable as far as possible from the DCCT Head.

## 2.4 Full-Scale Current

Rated full-scale primary current can be easily changed by carrying out multiple turns on the primary conductor hole.

The full-scale current can then be scaled by a factor of  $N$ , with  $N$  = number of turns of the primary conductor around the hole.

As an example, in the CT-100 a primary current full-scale of 50A and of 33.3A respectively is obtained by connecting primary conductor as shown in **Figure 9**. Using the same principle, in the CT-150 a primary current full-scale of 75A and of 50A respectively is obtained by connecting primary conductor as follows in **Figure 9**.

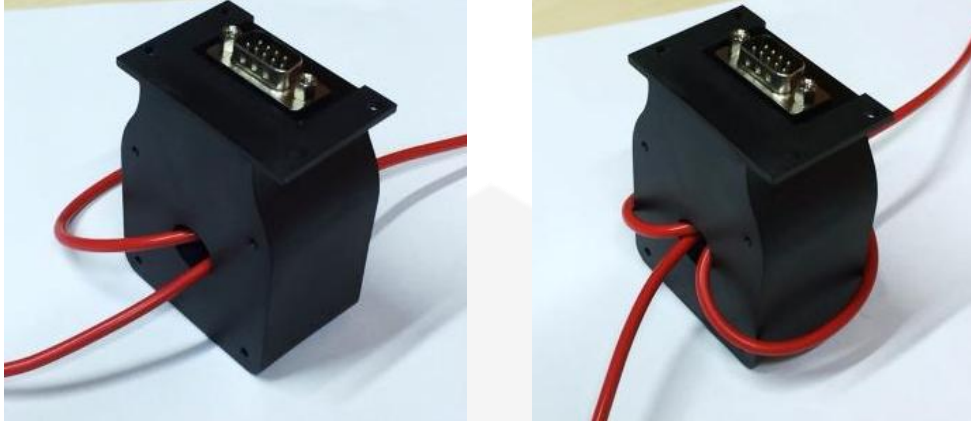

**Figure 9:** Primary full-scale current of 50A (left) and of 33.3A (right) in CT-100 or primary full-scale current of 75A (left) and of 50A (right) in CT-150

**Do not apply rated full-scale primary current (i.e. 100A for CT-100 and 150A for CT-150) when carrying out multiple turns on primary conductor hole.**

## 2.5 Secondary-side Signals

The signals on the “secondary” side of the CT-100/CT-150 series “C” version current transducers are found on pins #1, 2, 3, 6, 7 and 8 (please note that not all of them are present on all versions) of the DB-9 connector.

The same signals for the “P” version are found from pins #4 to #7 of the through hole 7-position strip.

### 2.5.1 Power Supply

Supply voltages for the CT-100/CT-150 series “C”-version have to be fed to pin #9 (+15V) and to pin #5 (-15V) of the D-sub 9-pin connector; both these voltages are referred to pin #4 (GND) and have a rated tolerance of  $\pm 6\%$  on the nominal values.

In the case of the “P”-version, the +15V have to be fed to pin #3 and the -15V to pin #2: they are both referred to the GND potential fed to pin #1 of the 7-position male connection-strip.

Maximum current that can be drawn from each one of these supply voltages is of 150 mA.

### 2.5.2 Secondary Current

On the standard CT-100/CT-150 Series versions the secondary current output  $I_S$ , scaled by the current transformation ratio 1:1000 (for CT-100) or 1:1500 (for CT-150) is fed to pin #6 in “C”-option and to pin #6 in the “P”-option. Current return pins are respectively found on pin #1 and on pin #7 in the “C”- and the “P”-option.

Maximum secondary current is rated at  $\pm 100$  mA and an external shunt resistor, which can be placed close to the user's desired measuring circuit, is needed in order to convert the current signal to voltage.

The voltage output pins ( $V_O$  and  $V_O$  RET) cannot be found on standard current output versions.

### 2.5.3 Voltage Output (“V” versions only)

A buffered output voltage signal is present on the voltage output versions of the CT-100V/CT-150V Series transducers in order to allow easier connection of the DCCT to an external circuit or an Analog to Digital converter.

The full-scale output bipolar signal  $V_O$  (pin #2 for “C”-version, pin #6 for the “P”) is referred to  $V_O$  RET (pin #7 on both “C” and “P” options) and the behavior is as follows:

- For CT-100 series:
  - +10V output if the primary current is +100A;
  - -10V output if the primary current is -100A;
- For CT-150 series:
  - +10V output if the primary current is +150A;
  - -10V output if the primary current is -150A.

This behavior can be resumed in the gain parameter  $G$ , in [V/A], expressed as the ratio between the transducer output voltage  $V_{V_O} - V_{V_ORET}$  and the primary current  $I_P$ .

$$G = \frac{V_{V_O} - V_{V_ORET}}{I_P}$$

This gain value is  $G = 0.1$  V/A = **100 mV/A** for the CT-100V versions and  $G = 1/15$  V/A for the CT-150V versions.

$V_O$  RET pin is not internally connected to ground GND (pin #4 on “C” and pin #1 on “P”) and it should be connected to ground directly using a single-point connection (e.g. on an external ADC ground pins or  $V_{IN-}$  pin). The availability of this “return” signal is very useful in order to avoid additional ground-loops and noise pickup on the voltage-output version of the transducer.

Please note that the maximum differential voltage between the  $V_O$  RET and the GND pin has to be kept within  $\pm 0.5$ V.

$$|V_{V_{ORET}} - V_{GND}| \leq 0.5 \text{ V}$$

In the voltage output “V”-versions of the transducers the current output pin  $I_s$  (pin #6) and its return (pin #1 on “C” and pin #7 on “P”) are not present.

Please note that output impedance for the “V”-version models is  $50 \Omega$  and it is low-pass filtered with a  $0.5\text{-}\mu\text{s}$  time constant.

### 2.5.4 STATUS Signal

A STATUS signal, obtained from the outputs of an optocoupler phototransistor (**Status+** and **Status-**, pins #8 and #3 on the “C” version and pins #4 and #5 on the “P” version respectively) is present on all versions of the CT-100/CT-150 Series. Please note that the OK- signal is not internally connected to the ground potential and can be connected to an external reference potential. A green LED is also present on the front side of the DCCT indicating the correct operation of the devices.

A pull-up resistor is needed (between the OK+ and some supply voltage referred to the OK- potential) in order to correctly obtain the correct signaling.

Two examples on how to connect the OK+ and OK- signals are hereafter presented in **Errore. L'origine riferimento non è stata trovata.** and in Figure 11.

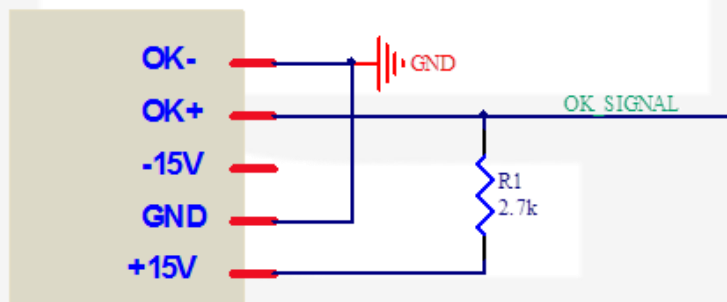

Figure 10: OUT OK signals connections using the +15V and the GND pins

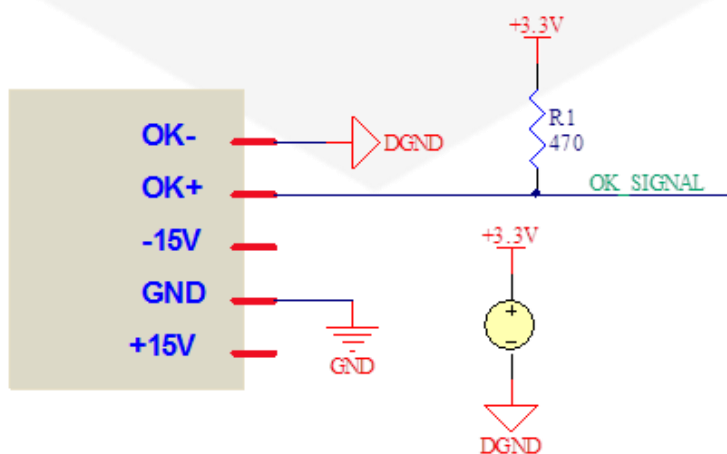

Figure 11: OUT OK signals connections as digital interfacing to +3.3V

Note that the connection scheme presented in **Figure 10** is referred to the GND potential and the OK\_SIGNAL is at low level (<0.4V) if the CT-100/CT-150 Series transducer is correctly working while it is at high level (>14.5V) when the transducer is not.

In the configuration presented in **Figure 11**, the current transducer can be easily interfaced to a digital microcontroller, a Digital Signal Processor or an FPGA, supplied by a +3.3V voltage source.

Please note that the +3.3V supply and the OK\_SIGNAL is referred to DGND potential, which can be the same or different from the GND potential on which the CT device is supplied from. The OK\_SIGNAL is found to be at low level (<0.4V) when the transducer is correctly working and at high-level (>3V) when not.



**Figure 12:** STATUS – OUT OK indications

The OUT OK green light is on, as shown in **Figure 12**, whenever the device is correctly working and regulating secondary output current – i.e. zero flux is established and secondary circuit is closed on the shunt resistor (external or internal in the “V” versions).

## 3. Ordering Options

The CT-100/CT-150 Series current transducers have different models and versions differing by the secondary output signal types and different connections. The ordering code is formatted as follows:



### Full Scale Range

**100** = 100A full scale current  
**150** = 150A full scale current

### Output Version

**empty** = current output  
**V** = voltage output

### Connections

**C** = DB-9 connector  
**P** = pin connections

*NOTE: fields/characters shaded in grey color are fixed.*

**Example:** the DC current transducer version CT-100V-C has a full scale measurable current of 100A, secondary voltage output and the DB-9 connector.

## 4. Technical Specifications

Technical Specifications for current transducers of the CT-100/CT-150 Series (both current and voltage output versions) are herein presented.

<i>Technical Specifications</i>	<i>CT-100</i>	<i>CT-150</i>
Current Transformation Ratio - N	1:1000	1:1500
<b>Maximum DC Primary Current - <math>I_{P(DC)}</math></b>	<b><math>\pm 100</math> A</b>	<b><math>\pm 150</math> A</b>
Maximum RMS Primary Current - $I_{P(RMS)}$	71 A	106 A
<b>Current Polarity</b>	<b>Bipolar</b>	
Maximum DC Secondary Current - $I_{S(DC)}$	$\pm 100$ mA	
<b>Maximum RMS Secondary Current - <math>I_{S(RMS)}</math></b>	<b>71 mA</b>	
External Shunt Resistor Value - $R_s$	0...40 $\Omega$	0...40 $\Omega$
<b>Small Signal Bandwidth (<math>\pm 3</math> dB) - typ. BW</b>	<b>&gt; 500 kHz</b> > 200 kHz ("V"-version)	<b>&gt; 300 kHz</b> > 200 kHz ("V"-version)
Equivalent Input Noise (@Bandwidth) *	< 1 ppm/FS @ 200Hz < 10 ppm/FS @ 50 kHz	
<b>Output Voltage ("V"-version) - <math>V_{OUT}</math></b>	<b><math>\pm 10</math> V</b>	
Output Voltage Gain ("V"-version) - $V_{OUT}/I_{P(DC)}$	1/10 V/A	1/15 V/A
<b>Maximum Output Current ("V"-version)</b>	<b><math>\pm 15</math> mA</b>	
Temperature Coefficient - TC	< 0.5 ppm/ $^{\circ}$ C typ. < 2 ppm/ $^{\circ}$ C ("V"-version)	
<b>Non-Linearity</b>	<b>&lt; 5 ppm</b> <b>&lt; 15 ppm ("V"-version)</b>	
Induction into Primary (0-100 kHz) typ.	35 $\mu$ V (RMS)	
<b>Offset (with factory calibration) *</b>	<b>&lt; 10 ppm/FS</b>	
Protection Signal	OK Status	
<b>Supply Voltage (<math>\pm 6\%</math>)</b>	<b><math>\pm 15</math> V</b>	
Current Consumption	50 mA + $I_s$	

Secondary Coil Resistance - $R_{SEC}$	43 $\Omega$	34 $\Omega$
Accuracy (typ.) *	< 30 ppm / FS < 0.25% / FS ("V" - version)	
Connections	D-sub 9 connector ("C"-model) 7-pin strip TH type ("P"-model)	
Operating Temperature Range	0°C - 50°C	
Mechanical (Outer) Dimensions	45 x 57 x 75 mm	
Primary Conductor Hole Diameter - $\varnothing$	16 mm	
Maximum Weight	250 g	

\* These specifications are guaranteed only when the CT sensor is used with the dedicated CAEN ELS PS1215 power supply

**Table 4:** Technical Specification

## 4.1 Equivalent Input Noise

The typical equivalent input noise of the CT-100/CT-150 transducers is hereafter presented as a function of the measuring bandwidth and of the output version. The connector topology does not affect the noise performances of the devices and the characterization is performed on the "C" connector versions. The table and its graph are valid for both current and voltage output options.

**CT-100/CT-150 Typical Equivalent Input Noise**

<i>Bandwidth</i>	<i>CT-100</i>	<i>CT-150</i>
200 Hz	0.5	1.6
1 kHz	2.5	3.7
10 kHz	3.5	6.3
50 kHz	4.5	6.8

**Table 5:** Equivalent Input Noise (typical values)

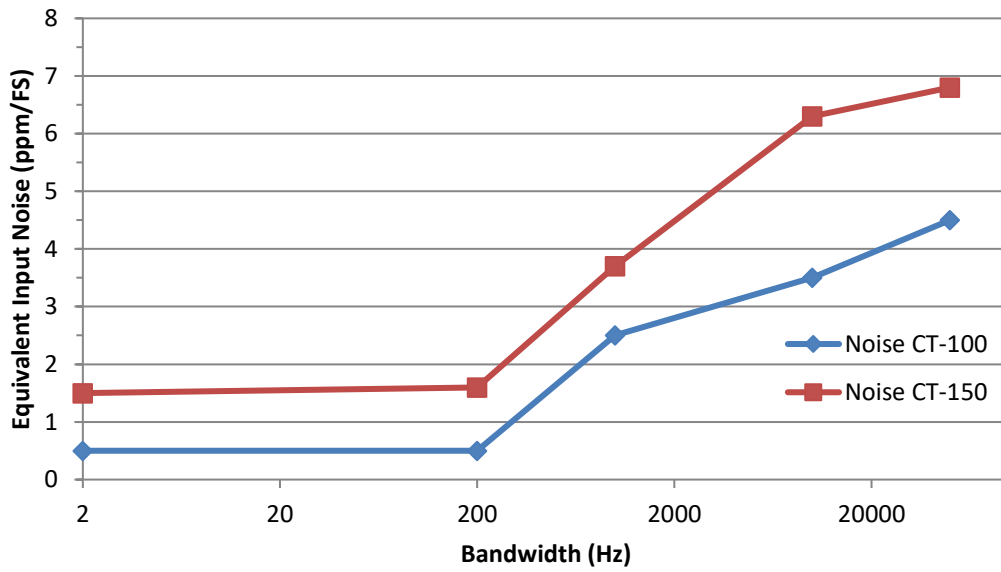

Figure 13: Equivalent Input Noise graph (typical values)

## 4.2 External Shunt Resistor

The maximum value of the external shunt resistor that can be connected on the  $I_s$  output pin in the current-output versions is shown hereafter in the following chart.

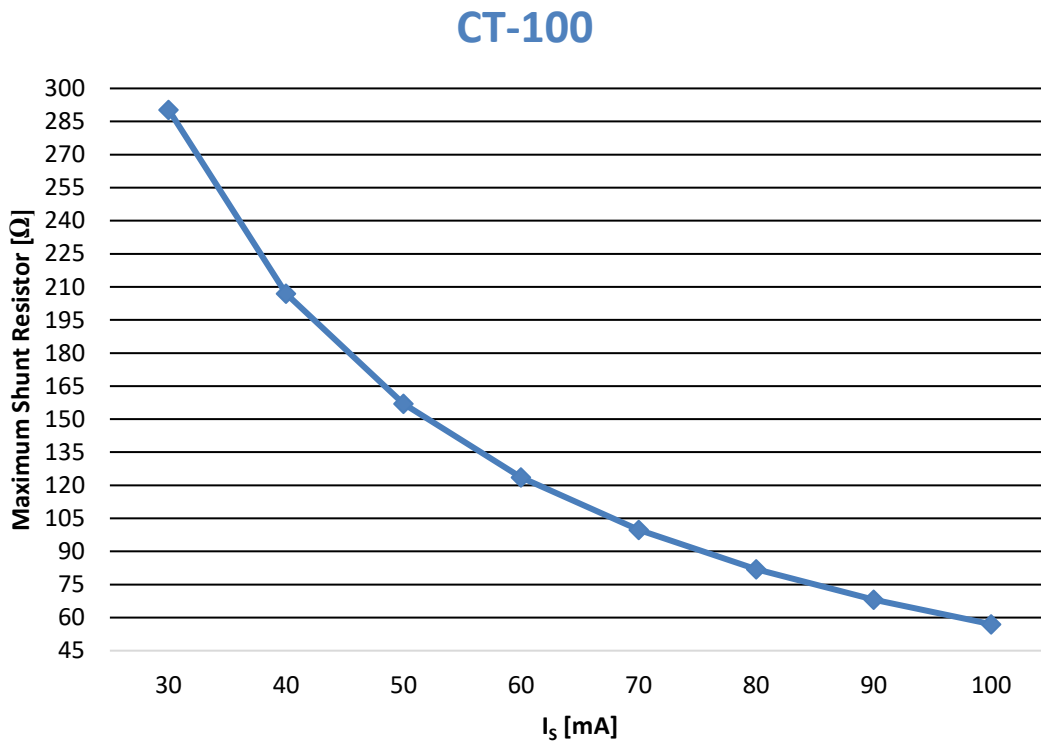

Figure 14: CT-100 maximum external shunt resistor (Current version only)

## CT-150

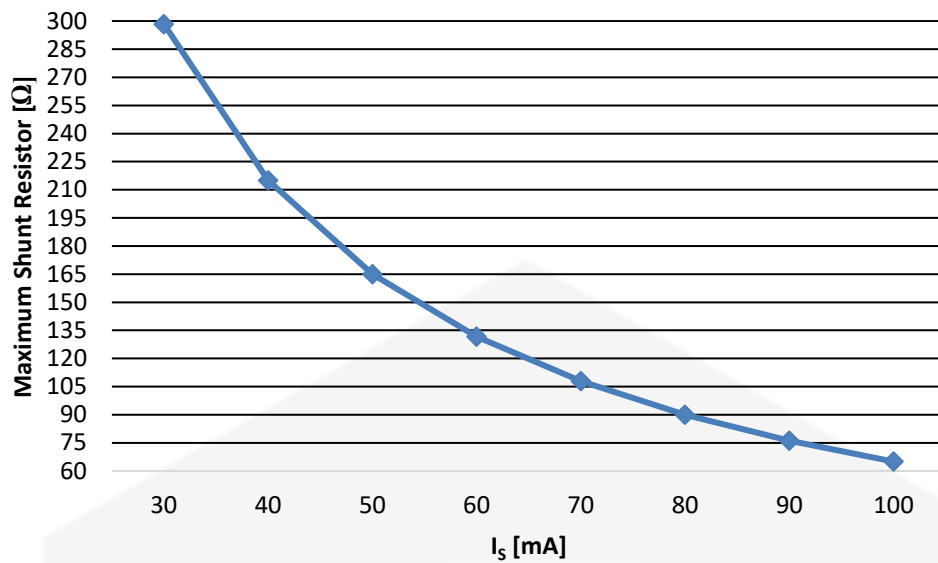

Figure 15: CT-150 maximum external shunt resistor (**Current** version only)

### 4.3 Insulation characteristics

In the following table are represented the insulation characteristics of the CT-100, CT-150 current transducers.

Parameter	Value	Reference
Rated insulation voltage (RMS), basic insulation	2000 V	IEC 61010-1 conditions - over voltage cat III - pollution degree 2
Rated insulation voltage (RMS), reinforced insulation	600 V	IEC 61010-1 conditions - over voltage cat III - pollution degree 2
Rated insulation voltage (RMS), basic insulation	1000 V	EN 50178 conditions - over voltage cat III - pollution degree 2
Rated insulation voltage (RMS), reinforced insulation	600 V	EN 50178 conditions - over voltage cat III - pollution degree 2
RMS voltage for AC insulation test, 50/60 Hz, 1 min	5.4 kV	Between primary and secondary + shield
Clearance (primary – secondary)	11 mm	Shorter distance path

Table 6: Insulation characteristics

The voltage insulation category could be improved, if insulated cable is used for the primary circuit.

## 5. Mechanical Dimensions

The mechanical dimensions of the CT-100/CT-150 Series DC Current Transducers are hereafter presented (all dimensions are in **mm**).

### 5.1 CT-100/CT-150 Series “C”-version

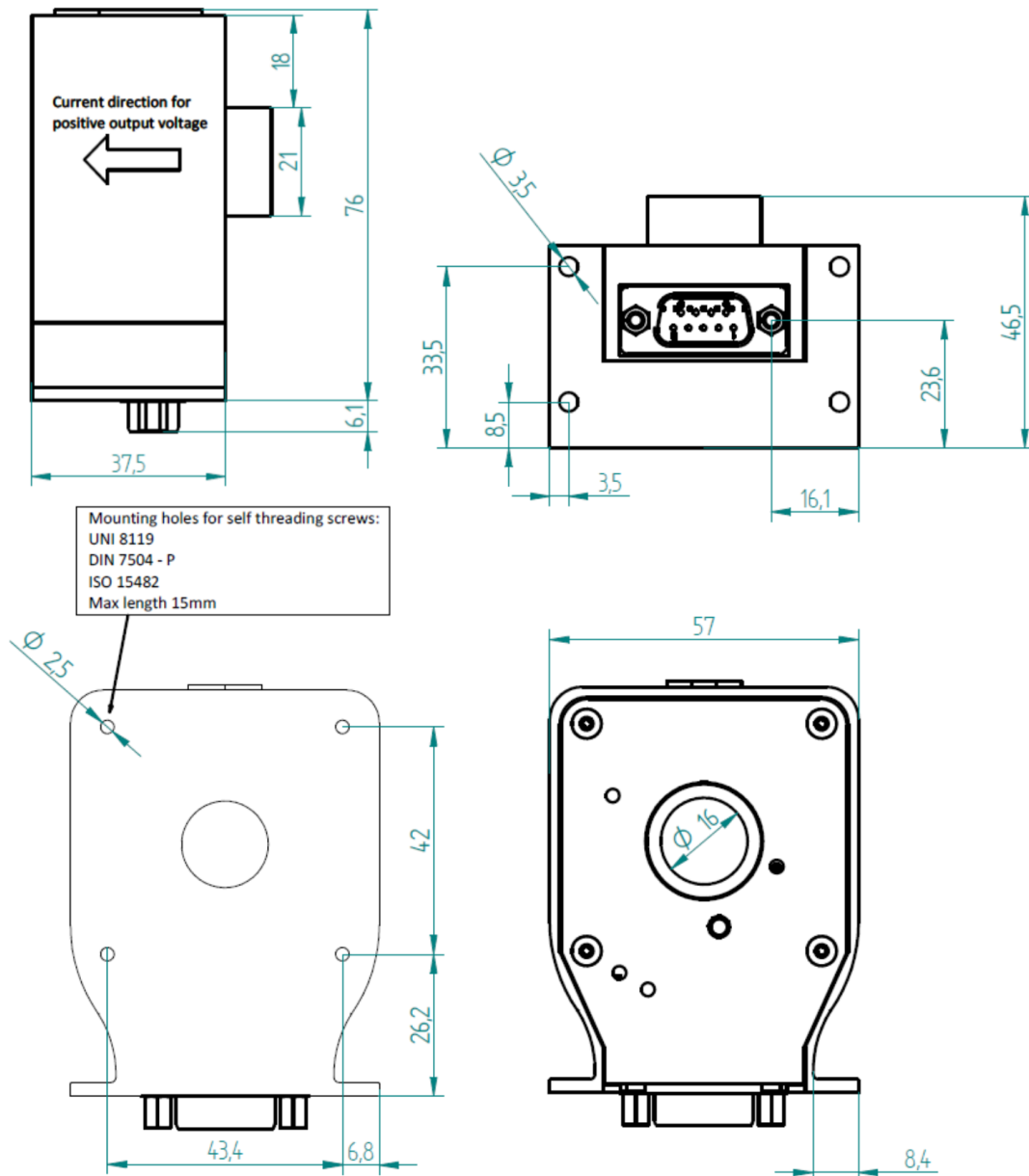

**Figure 16:** Mechanical drawings for CT-100/CT-150 Series “C” Version

## 5.2 CT-100/CT-150 “P”-version

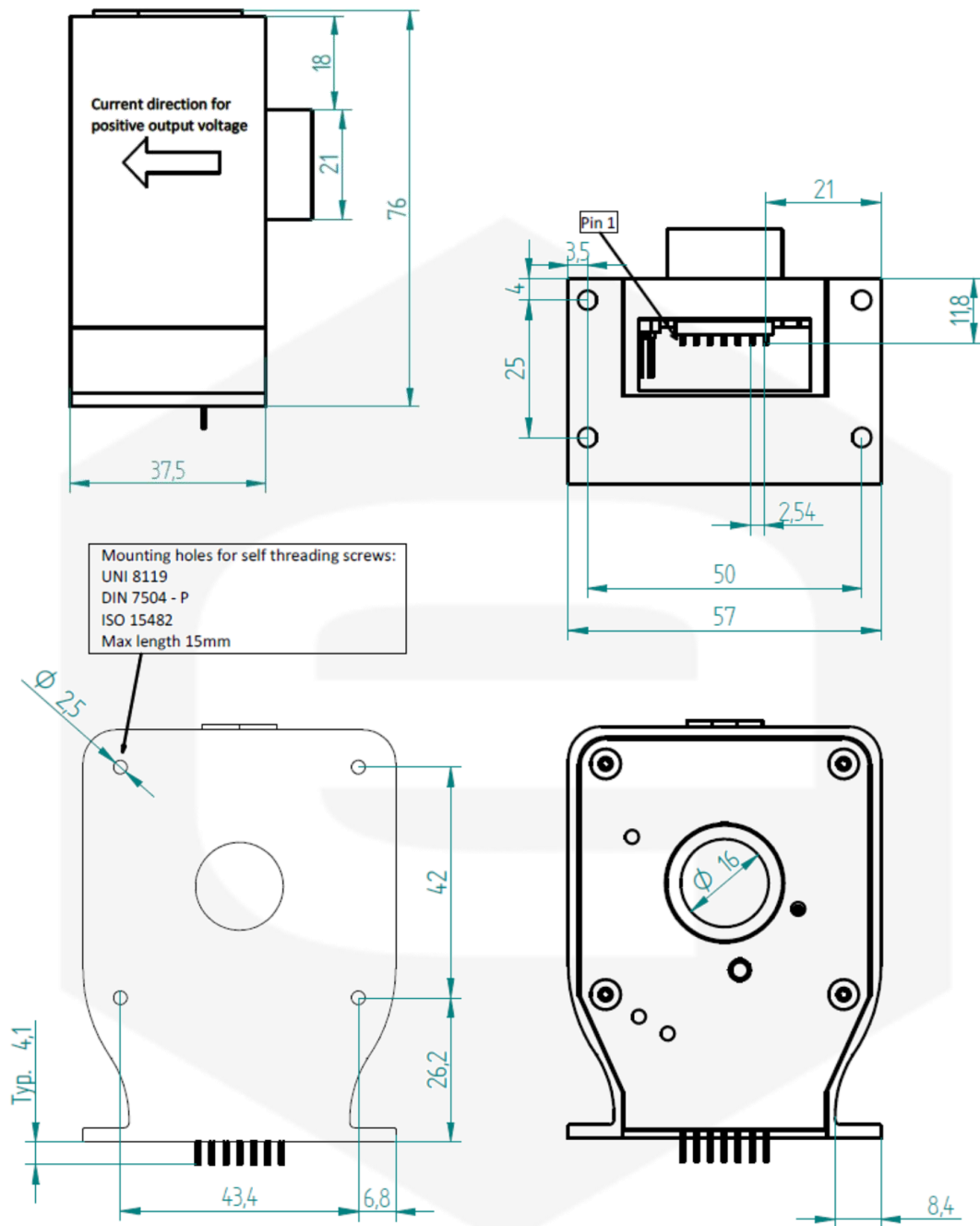

Figure 17: Mechanical drawings for CT-100/CT-150 Series “P” Version

