

FAST-PS-M

Current- and Voltage-Controlled Monopolar Digital Power Supply Series



User's Manual



All Rights Reserved
© CAEN ELS s.r.l.
Rev. 3 – October 2025



This product is **CE** & **UKCA** compliant.



CAEN EL S s.r.l.

Via Karl Ludwig Von Bruck 32– 34144 Trieste (TS)
Italy

Mail: info@caenels.com

Web: www.caenels.com



User Manual – Models – Options – Custom Models

This manual covers the following standard Power Supplies models:

- **FAST-PS-M 3030-900**
- **FAST-PS-M 6010-600**
- **FAST-PS-M 7508-600**
- **FAST-PS-M 10006-600**

The FAST-PS can be equipped with the following options:

- **FAST-PS-M AN-CTRL:** Analog Control Input (± 10 V) on BNC connector – optional
- **FAST-PS-M TGR-IN:** Trigger Input on BNC connector

This manual cover the Custom Model named as following:

FAST-PS-M-Cxx yyzz-kkk

Where:

- xx is the Customization code
- yy is the maximum output current expressed in Amps
- zz is the maximum output voltage expressed in Volts
- kkk is the maximum output power

Additional useful manuals are:

- Remote Control Manual
- Visual PS User's Manual

For technical assistance please refer to the following contact:

CAEN ELS s.r.l.
Karl Ludwig Von Bruck, 32
34144 Trieste (TS) – Italy

Phone: +39 040 883 0028
Fax: N/A
e-mail: support@caenels.com

Table Of Contents

Safety information	7
1. INTRODUCTION.....	10
1.1 USER MANUAL CONTENT	10
1.2 FAST-PS-M OVERVIEW	10
1.3 FAST-PS-M AT A GLANCE	11
1.4 MODES OF OPERATION.....	13
1.4.1 Regulation Mode.....	13
1.4.2 Local, Remote, Fast-Interface Control Mode	13
1.4.3 Update Mode.....	14
2. POWER SUPPLY MAIN FEATURES	15
2.1 CONNECTORS	15
2.1.1 Power Cables Connectors.....	15
2.1.2 Power Cables Connectors for the FAST-PS-M 3030	16
2.1.3 I/O Connectors.....	17
2.1.4 Remote Sensing.....	18
2.2 OPTIONS.....	19
2.2.1 Analog Control Input	20
2.2.1 Trigger Input.....	21
2.3 FRONT PANEL INDICATORS	22
2.4 INTERNAL PROTECTIONS.....	23
2.4.1 Earth Leakage Current	23
2.4.2 Earth Fuse.....	23
2.4.3 Regulation Fault	23
2.4.4 Input OVerCurrent - OVC	24
2.4.5 OVerPower - OVP	24
2.4.6 DCCT Not OK.....	25
2.4.7 OVerTemperature - OVT	25
2.4.8 DC-Link Undervoltage.....	25
2.5 WAVEFORM	25
3. INSTALLATION.....	27
3.1 PREPARATION FOR USE.....	27
3.2 INITIAL INSPECTION	27
3.3 MOUNTING.....	27
3.3.1 Rack Mounting.....	28
3.3.2 Desktop use	28
3.4 AC INPUT POWER CONNECTION	28
3.4.1 AC Source requirement.....	29
3.4.2 AC Input Cord.....	29
3.4.3 Wire selection.....	29
3.4.4 Remote Sensing	30
3.4.5 Grounding Outputs	31
4. LOCAL CONTROL	33
4.1 NAVIGATION SWITCH.....	33
4.2 DISPLAY.....	34



4.2.1	Power-up.....	34
4.2.2	Home Screen.....	34
4.2.3	Menu Page.....	35
4.2.3.1	Control Page.....	36
4.2.3.2	Config Page.....	37
4.2.3.3	Advanced Page.....	37
5.	MECHANICAL DIMENSIONS.....	38
5.1	FAST-PS-M 3030 MECHANICAL DIMENSIONS.....	39
6.	TECHNICAL SPECIFICATIONS	40



Document Revisions

Revision	Date	Comment
0.3	October 7 th 2015	Draft Release
1.0	November 26 th 2015	First Public Release
1.1	December 14 th 2015	Fixed some errors and images added
1.2	July 15 th 2016	Updated Images and Installation Chapter
1.3	December 21 st 2016	Added information on cablings and analog input
1.4	August 1 st 2017	Added FAST-PS-M 3030-900 model
1.5	November 15 th 2017	Added Auto shut down feature on Display
1.6	May 3 rd 2021	Typographical error fixed
1.7	November 22 nd 2022	Added UKCA compliance logo
2	August 8 th 2024	Updated address and revision numbering
3	October 16 th 2025	Updated the pictures and reviewed the Local Control section.

Safety information

The following table shows the general environmental requirements for a correct operation of referred instruments in this User’s Manual:

Environmental Conditions	Requirements
Environment	Indore use
Operating Temperature	0°C to 50°C
Operating Humidity	20% to 80% RH (non-condensing)
Altitude	Up to 2000 m
Pollution degree	2
Overvoltage Category	II
Storage Temperature	-10°C to 60°C
Storage Humidity	5% to 90% RH (non-condensing)

The following symbols are used within this manual or are reported in the box and along this manual:



- **Caution:** Documentation must be consulted in all cases where this symbol is marked

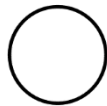

- **Off (Power)**



- **On (Power)**

WARNING

- The **WARNING** sign denotes a hazard. An attention to a procedure is called. Not following procedure correctly could result in personal injury. A **WARNING** sign should not be skipped and all indicated conditions must be fully understood and met.

CAUTION

- The **CAUTION** sign denotes a hazard. An attention to a procedure is called. Not following procedure correctly could result in

damage to the equipment. Do not proceed beyond a CAUTION sign until all indicated conditions are fully understood and met.

CAEN ELS will repair or replace any product within the guarantee period if the Guarantor declares that the product is defective due to workmanship or materials and has not been caused by mishandling, negligence on behalf of the User, accident or any abnormal conditions or operations.

Please read carefully the manual before operating any part of the instrument

WARNING

Do NOT open the boxes

CAEN ELS s.r.l. declines all responsibility for damages or injuries caused by an improper use of the Modules due to negligence on behalf of the User. It is strongly recommended to read thoroughly this User's Manual before any kind of operation.

CAEN ELS s.r.l. reserves the right to change partially or entirely the contents of this Manual at any time and without giving any notice.

Disposal of the Product

The product must never be dumped in the Municipal Waste. Please check your local regulations for disposal of electronics products.



WARNING

- Do not use this product in any manner not specified by the manufacturer. The protective features of this product may be impaired if it is used in a manner not specified in this manual.
- Do not use the device if it is damaged. Before you use the device, inspect the instrument for possible cracks or breaks before each use.
- Do not operate the device around explosives gas, vapor or dust.
- Always use the device with the cables provided.
- Turn off the device before establishing any connection.
- Do not operate the device with the cover removed or loosened.
- Do not install substitute parts or perform any unauthorized modification to the product.
- Return the product to the manufacturer for service and repair to ensure that safety features are maintained

1. Introduction

1.1 User Manual Content

This manual contains basic operating instructions and installation instructions for the FAST-PS-M monopolar power supplies; information contained in this manual refer both to the standard and custom FAST-PS-M models.

In this manual only the local control of the power supply is covered, while for the remote-control interface the “VISUAL manual” is the reference. The expert user can then refer to the “Remote Control Manual” in order to use the dedicated programming language of the power supplies.

1.2 FAST-PS-M Overview

High performances, high efficiency, high stability, easiness of configuration and maintenance are the key features of the FAST-PS-M power supply series.

The FAST-PS-M is an independent current- or voltage-controlled digital bipolar power supply module. There are available different models with different current and voltage ranges:

Model Name	Current	Voltage	Maximum Power
FAST-PS-M 3030-900	30 A	30 V	900 W
FAST-PS-M 6010-600	60 A	20 V	600 W
FAST-PS-M 7508-600	75 A	8 V	600 W
FAST-PS-M 10006-600	100 A	6 V	600 W

Table 1: FAST-PS-M models

CAEN ELS could produce also customized FAST-PS-M with different current and voltage ranges based on special request; if this manual is ship with a custom FAST-PS-M different form the mentioned in Table 1 refer to Appendix A for the parameter differing from standard model.

The FAST-PS-M module is compact and fits in a single 19-inch 1U standard crate. The power unit implements a completely digital control loop with a Pulse Width Modulation (PWM) generation technique that allows to adapt the system to any load condition.

The control board houses a dedicated FPGA with integrated dual-core ARM CPU. The loop regulation task is performed directly by the FPGA logic, in order to

have high performance and deterministic loop control. On the ARM CPU an embedded Linux OS is installed, with the task to supervise all process as communication, diagnostics and local interface handling.

Remote communication is guaranteed by means of an Ethernet 10/100/1000 autosensing socket present on the front panel of the power unit. The power supply can be also monitored and controlled via a navigation switch and a graphic high resolution color display featuring user-friendly menus.

In addition to the standard Ethernet interface it is possible to communicate with the unit using the SFP-ports on the front panel. This interface allows to communicate with the unit using a proprietary packet structure with a very high update rate (more than 10 kHz). These ports are connected directly to the FPGA logic and so the given packet is elaborated directly by the hardware logic.

This approach eliminates the software stratification that manages the packet and the computational time is smaller and deterministic, allowing a very high update rate of the setpoint, giving the user more flexibility and excellent rates for the digital control of the power supply.

1.3 FAST-PS-M at a glance

The FAST-PS-M system is composed by a single 19-inch 1U crate. The FAST-PS-M unit and its I/O connections are presented in **Figure 1** (front view) and **Figure 2** (rear view).



Figure 1: FAST-PS-M front view

On the front side of the FAST-PS-M unit are placed: a power switch, a colour graphic display with navigation switch for the local control of the module, three communication sockets (2 SFPs and one Ethernet ports), four status LEDs and one USB device connector.



Figure 2: FAST-PS-M rear view

On the rear side of the unit are placed: AC power line input, fuse holder, the output connection, the D-Sub 15 Female Pin I/O connector. From units of all models with SN ending in x010 and later, a separate connector for the voltage remote sensing is also present below the I/O connector.

The FAST-PS-M 3030, as it carries up to 30 Amperes only, it is provided with 2 x WGKV 10/Z SW output connectors, instead of metal bars:

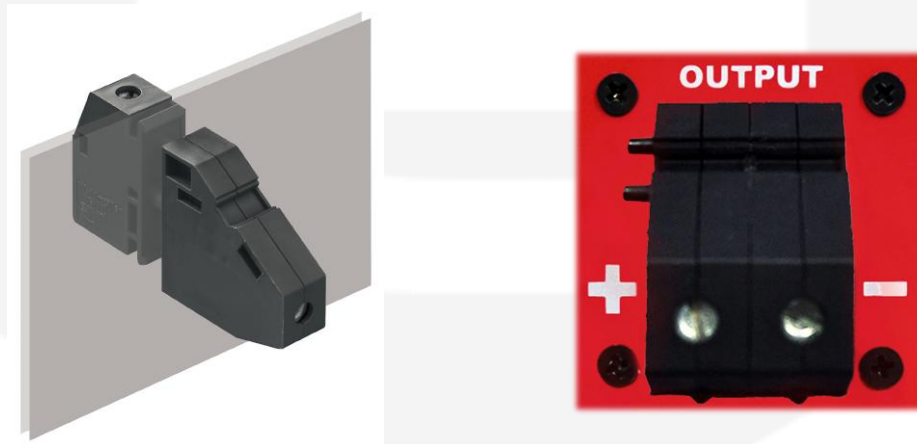

Some models can mount one or two BNC connectors reserved for additional features of the power supply.

1.4 Modes of Operation

The FAST-PS-M system has multiple features and multiple configurations that allow using the unit for a very widespread topology of applications.

A brief summary of the basic configurations that the unit is able to handle are hereafter presented.

1.4.1 Regulation Mode

The FAST-PS-M can be used as current-controlled or voltage-controlled monopolar units. The regulation types are:

- **C.C.** mode: it is the Constant Current regulation mode. The power supply regulates the output current set by the user;
- **C.V.** mode: it is the Constant Voltage regulation mode. The power supply regulates the output voltage set by the user.

In C.V. mode it is possible to use the *remote sensing* terminals that allow regulating the output voltage directly on the load thus compensating the voltage drops on the output cables. The maximum voltage drop that the power supply is able to compensate is of 0.5V.

1.4.2 Local, Remote, Fast-Interface Control Mode

The FAST-PS unit can be controlled in three main different ways, hereafter listed:

- **LOCAL** control: the unit can be controlled directly via the front panel color display and the navigation switch. When the unit is set in LOCAL mode it is possible to perform readings and monitor from the remote interface but any setting command is denied;
- **REMOTE** control: the unit is controlled via the TCP-IP Ethernet interface. The setting and control of the unit can be performed exclusively via this interface while monitoring is still possible from the local display. Please refer to “Remote Control Manual” and “VISUAL Manual” for this feature;
- **FAST-INTERFACE** control: this interface allows controlling the unit via a proprietary protocol over the SFP/SFP+ interfaces (optical or electrical) and it is meant to be used for very fast applications. Update rates of more than 10 kHz are reachable using this communication channel. Please refer to “Operation Manual” for this feature;

1.4.3 Update Mode

The current or voltage setting of the unit can also be performed in four different modes:

- **NORMAL**: the update of the set-point (current or voltage, depending on the operation mode) is performed as soon as a new set-point is received via the remote, local or fast interfaces;
- **WAVEFORM**: the update of the set-point is performed on a specific timing (defined as a “waveform” attribute, more information on the *Waveform* section) and it is done internally;
- **TRIGGER**: the set-point is updated by an external event – i.e. a hardware trigger coming from the rear BNC connector. Please note that this mode of operation is obtainable only on the units that have the external trigger input connector installed (ordering option – factory configurable);
- **ANALOG INPUT**: the unit is controlled by an external signal that is fed to the rear BNC connector. The unit acts as a C.C. or C.V. generator depending on the pre-set Regulation Mode. This option is only available in units that have been factory configured (ordering option).

Please note that the last two Update Modes of operation are available only in models that have been factory configured at the time of purchase to have the Trigger Input and/or the Analog Control Input features.

2. Power Supply Main Features

The features listed in this chapter are common to the FAST-PS-M family and can be regarded as the basic features of this power supplies family.

2.1 Connectors

Three different types of connection are present in FAST-PS-M power supplies: power cables connector (bus-bars), I/O connectors and remote sensing connectors. Analog control input and trigger input are on BNC connectors which are optional and needs to be added at the time of the ordering.

2.1.1 Power Cables Connectors

The load needs to be connected to the output connector placed on the rear panel of the unit as shown in **Figure 3**.



Figure 3: Output Connector

The symbols “+” and “-” on the rear panel indicate the positive and negative polarity of the terminal respectively.

2.1.2 Power Cables Connectors for the FAST-PS-M 3030

The load needs to be connected to the output connector placed on the rear panel of the unit as shown in **Figure 3**. This type of connector offers a convenient and reliable form of connection; it is suggested to connect the wire directly to the connector. The suggested cross-sectional area of the cables is rated to be from AWG 24 to AWG 6.

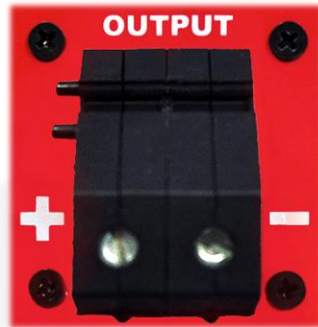

Figure 4: Output Connector

The symbols “+” and “-” on the rear panel indicate the positive and negative polarity of the terminal respectively.

2.1.3 I/O Connectors

The FAST-PS-M module has two configurable dry-contact input interlocks and output status signals that are directly available on the D-Sub 15 Pin Female connector on the rear panel (**Figure 5**).

A mating connector, a standard D-Sub 15 Pin Male type, can be installed in order to use/access these available signals.

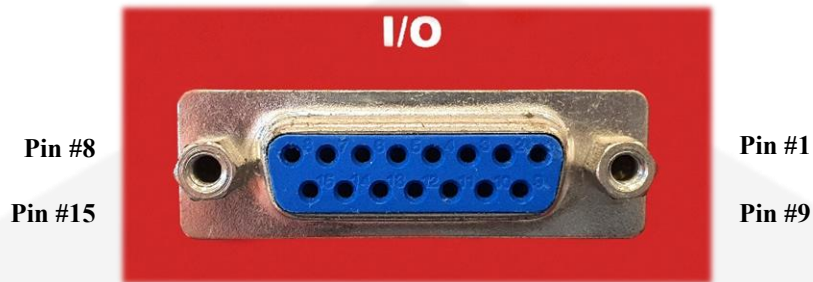

Figure 5: I/O Connector

The pin index of the D-Sub 15 rear connector is summarized in the following table:

Pin Number	Signal name
#1 - #4	DNC
#5	Magnetic Relay Common Contact (C-TAP)
#6	Magnetic Relay Normally Closed Contact (NC-TAP)
#7	Interlock #2 input
#8	Interlock #1 return
#9 - #12	DNC
#13	Magnetic Relay Normally Open Contact (NO-TAP)
#14	Interlock #2 return
#15	Interlock #1 input

Table 2: D-sub 15 Pin pinout

DNC = DO NOT CONNECT

The magnetic relay provides the output status of the power module: when the module is ON, the Normally Closed contact (NC-TAP) switch opens and vice-versa. The absolute maximum current that can be sunk by the output status magnetic relays (pins #5, #6 and #13) is 200 mA.

The interlock pins are galvanically isolated from ground and outputs terminal, nevertheless the absolute maximum voltage, referred to ground, that pins can sustain is 48V. The two interlocks inputs have their own return connection. The interlock is hardware-activated when the input pin and its corresponding return pin are shorted. Do not apply voltage between any input interlock and its corresponding return.

The configurability of the FAST-PS-M series allows users to decide what interlock are enabled or not, set the interlock “trip” level (i.e. low or high), the time of intervention (the time that an interlock signal has to be at the trip level before generating a fault condition) and an associated interlock name. These advanced features are discussed in the “Remote Control Manual”. The interlocks are disabled by default.

2.1.4 Remote Sensing

From FAST-PS-M of any model with SN (Serial Number) ending with x10 and later – i.e. x11, x12, etc. – there is a different voltage-sensing connector on the rear panel that allows using the voltage sensing feature especially when using the power supply in C.V. mode. Connector is shown in **Figure 6**.

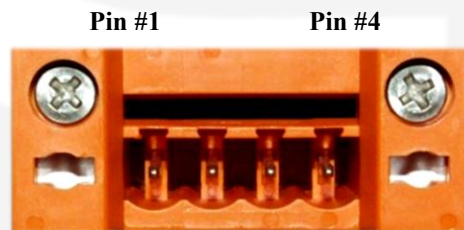

Figure 6: Remote Sensing Connector

The FAST-PS-M can be used in constant voltage (CV) mode and two remote sensing terminals are present on the corresponding connector on the rear panel:

- V_{SENSE+} on pin #1: +S;
- V_{OUT+} on pin #2: +;
- V_{OUT-} on pin #3: -;
- V_{SENSE-} on pin #4: -S.

By using these two “sensing” pins it is possible to sense the output voltage directly on the load, thus recovering possible voltage drops on the output cables up to 0.5V.

It is strongly suggested to use twisted cables when using the *remote sensing* feature in order to minimize possible noise pick-up.

The FAST-PS-M is shipped with a mating connector for the remote sensing that short-circuits the +S and + pins and the –S and – pins respectively. This configuration performs the remote sensing directly at the output connector of the power unit. Leaving +S and –S pins disconnected will make the power supply sense the output voltage directly at the output terminal connections. When using the remote sensing feature leave pins #2 (+) and #3 (–) disconnected.

In order to perform remote sensing at different points – e.g. the load terminals – it would be necessary to connect Pin #1 and Pin #4 as in **Figure 7**:

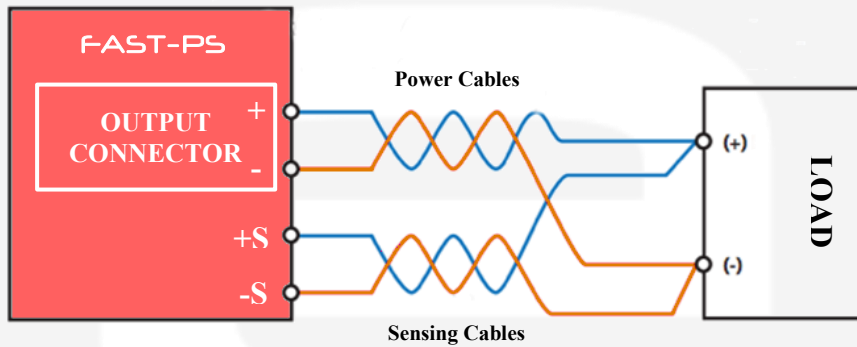

Figure 7: Example of Remote Sensing

2.2 Options

The FAST-PS-M can be configured with options that are factory-configured and can be found on the rear panel in places of connectors A and B.

The standard version of the FAST-PS-M, on the rear panel, is as shown in the following **Figure 8** and **Figure 9**.

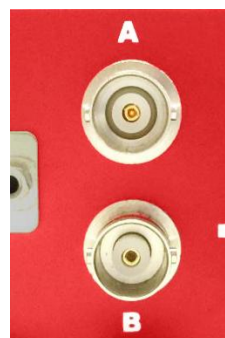
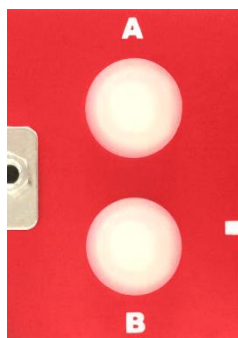

Figure 8: no options installed

Figure 9: A and B options installed

Options A and B are related to the following ordering codes (to be added at the time of the order):

Ordering Code	Description
FASTPSACINXA	Analog Control Input ($\pm 10V$) on BNC connector - <i>optional</i>
FASTPSTRINXA	Trigger Input on BNC connector - <i>optional</i>

A brief description of the two options is presented hereafter.

2.2.1 Analog Control Input

An input that allows the FAST-PS-M to be controlled as an “amplifier” is provided on the rear panel on a BNC connector on the “A” socket. This input is labelled as “AN CTRL”.

This input accepts signals ranging from 0V to +10V and generates an output which is proportional to the input signal, meaning a 0 for a 0V input and Full-Scale for a +10V input. An example of the relation between the analog input signal and the output (can be either current or voltage, depending on the Regulation mode) is shown in **Figure 10**.

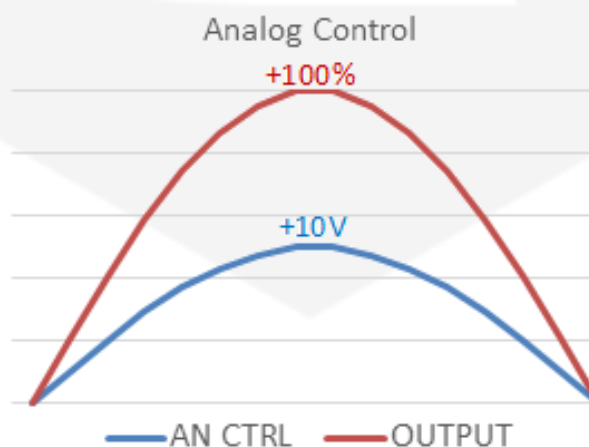

Figure 10: AN CTRL vs OUTPUT dependence

Please note that the bandwidth of the analog control input is internally limited to 1 kHz

2.2.1 Trigger Input

An input that allows the FAST-PS-M to be triggered is provided on the rear panel on a BNC connector on the “B” socket. This input is labelled as “TRG IN”.

This input accepts TTL (5V) and LVTTTL (3.3V) compatible signals and should be driven by a low-impedance source or generator.

The logic levels are subject to a hysteresis that allows for this recognized values that guarantee correct operation of the trigger as listed in **Table 3**:

Logic Level	Value
Low-to-HIGH	> 2.2 V
High-to-LOW	< 0.7 V

Table 3: Trigger Logic Levels

The absolute maximum rating for the Trigger Input signal is of **5.5 V** (a higher voltage level applied to this input can seriously damage the device).

A visual representation of the voltage levels for the trigger operation is presented in the following **Figure 11**:

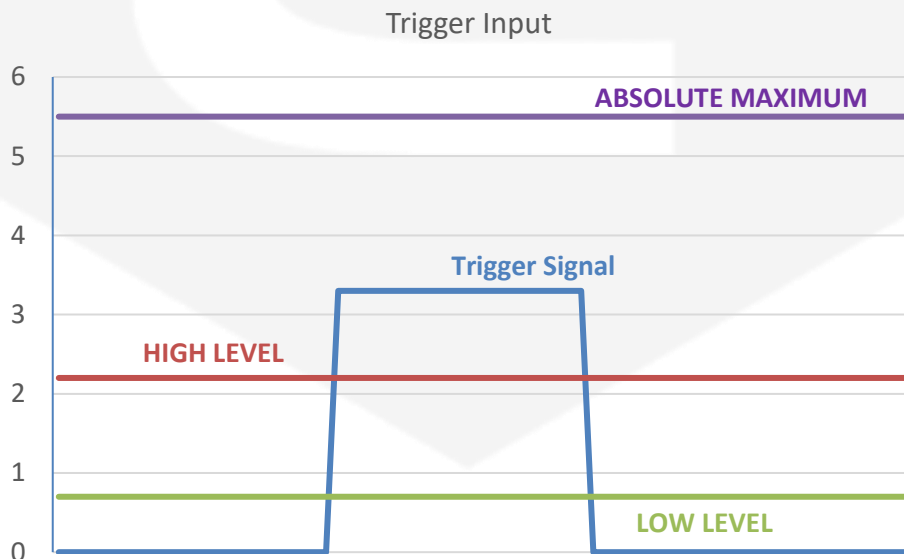

Figure 11: Trigger Thresholds

2.3 Front Panel Indicators

The FAST-PS-M has four (4) front panel LED indicators as shown in the following **Figure 12**.

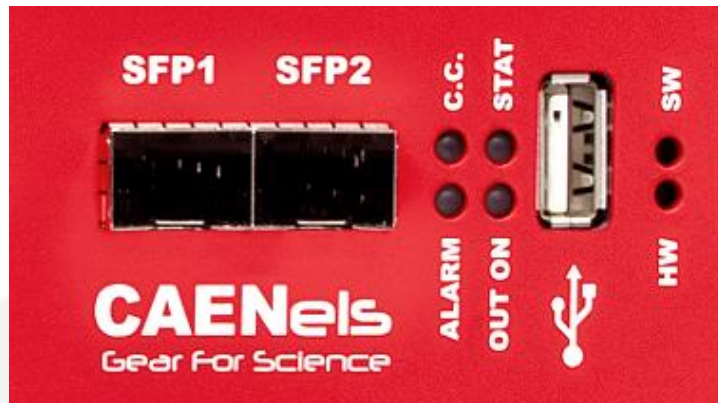

Figure 12: front panel indicators

The front panel indicators and their behaviour are hereafter listed (clockwise starting from top-left):

- **C.C.:** Constant Current mode (**blue**). If turned on, the FAST-PS is working in constant-current mode. When off, it is regulating the output voltage;
- **STAT (green):** signals the correct operation of the module diagnostics. The blinking signaling the correct operation has a 1-second period;
- **OUT ON (blue):** it signals if the output is enabled or not. The blue LED is on if the output is enabled and it is regulating output current or voltage;
- **ALARM (red):** if turned on signals that the power unit has experienced a fault condition. It is necessary to perform a “reset fault” command in order to turn off this LED and to turn to module output again (only if the fault condition/cause has been removed).

2.4 Internal Protections

The FAST-PS-M is equipped with several internal protections that allow configuring the unit for optimal operation. These protections have the dual use of protecting the unit and the connected load/device from unwanted damages or undesired operation conditions.

A brief description of the FAST-PS internal protections is hereafter presented with some more basic considerations on their operation and use. It is highlighted that this section is a general overview on internal protections, which needs to be integrated with the “Remote Control Manual” or the “VISUAL Manual” to be mastered.

In the case of a fault condition the power supply needs to be reset by the user before turning the power supply output back on again. Different values related to a fault condition can be set, and these procedures are explained in the “Remote Control Manual” and in the “VISUAL Manual”, together with the commands to reset the power supply after a fault condition.

2.4.1 Earth Leakage Current

This protection continuously monitors the current flowing to earth and it has a settable threshold [A] that can be set by experienced users.

2.4.2 Earth Fuse

An earth fuse is present on the rear side of each FAST-PS and it is rated at 1A Fast Acting. The fuse housing is shown in **Figure 13**.



Figure 13: earth fuse housing

2.4.3 Regulation Fault

This fault is generated when the power supply is not able to correctly regulate the output current or output voltage (in CC and CV mode respectively).

Different thresholds for the differential current, differential voltage and the intervention time can be set by experienced users.

A typical example of a regulation fault is represented by a 1-Ω load on a FAST-PS-M 10006-600 for example where the maximum power supply output voltage is 6V. By setting a current of 10A to the load, the output voltage should reach a value of 10V which obviously is not feasible: once the power unit supplies 6A to the load it already reaches the maximum output voltage condition. The power unit recognizes this difference between the set-point – i.e. 10A – and the actual output current, thus generating a “regulation fault” condition.

2.4.4 Input OVerCurrent - OVC

The internal current drawn from the AC/DC power section of the unit is sensed by a hall transducer that, in conjunction with a comparator, generates a signal that turns off the device. The threshold value of intervention depends on the FAST-PS-M specific model and cannot be changed by the user.

2.4.5 OVerPower - OVP

The FAST-PS-M can work continuously at a 5% over its power rating as expressed in the specifications.

The module is able to work at a power comprised between 5% and 10% over its rating – i.e. between 105% and 110% – for a 20-second period before turning off on an over-power fault.

If the actual output power drawn from the power supply is more than 10% above its nominal ratings the power unit will shut down after 1 second.

This behaviour is summarized in the following Table 4 (an example of a FAST-PS-M 10006-600 unit is also listed):

Output Power	Time of Operation
<p>< 105% of P_N <i>e.g. FAST-PS-M 10006-600: < 630W</i></p>	Continuous
<p>< 110% of P_N <i>e.g. FAST-PS-M 10006-600: < 660W</i></p>	20 s
<p>≥ 110% of P_N <i>e.g. FAST-PS-M 10006-600: ≥ 660W</i></p>	1 s

Table 4: FAST-PS Output Power

where P_N is the rated nominal output power of the power supply unit, as indicated in the technical specifications.

2.4.6 DCCT Not OK

The current transducer which is acting as the sensor unit for the feedback digital loop is constantly monitored and if any problem in connections is recognized, this fault will arise turning off the power supply.

2.4.7 OverTemperature - OVT

Internal monitoring of temperature is performed in different places inside the FAST-PS-M power supply. If a pre-defined threshold is exceeded by any of these internal sensors, an OVT condition is generated, thus shutting off the power unit.

The threshold value [°C] can be set by experienced users. A reset fault operation needs to be executed on the status register of the FAST-PS-M before turning the output off again.

2.4.8 DC-Link Undervoltage

The FAST-PS-M is composed internally by a power AC-DC section cascaded with a DC-DC stage. The voltage generated by the AC-DC section is also called DC-Link and it is proportional to the maximum rated voltage for the specific model. Usually the DC-Link voltage is about 20% higher than the rated output of the FAST-PS-M.

A continuous monitoring of the DC-Link voltage is performed in order to always guarantee the capability of obtaining the maximum voltage from the power supply. If the DC-Link drops below a certain threshold, the power supply unit could not be able to regulate correctly or some faulty conditions have arisen so that a fault conditions is generated.

It is necessary to reset the status register and to get rid of the fault cause before turning the power supply back on again.

2.5 Waveform

The FAST-PS is able to act as a waveform generator both in current and in voltage regulation modes.

The waveform is stored internally in a point-by-point manner and it gives a lot of flexibility since the maximum number of points of the waveform can be defined as well as the sampling period (of the waveform execution).

The minimum time interval for the waveform execution period is rated at 0.1 ms = 100 μ s, giving an equivalent output waveform update rate of 10 kHz.

In order to correctly execute the output waveform, it is necessary to “tune” the PID regulator parameters of the power supply to the specific load (and have an adequate load at the output).

More information on the waveform feature can be found in the corresponding command section in the “Remote Control Manual”.

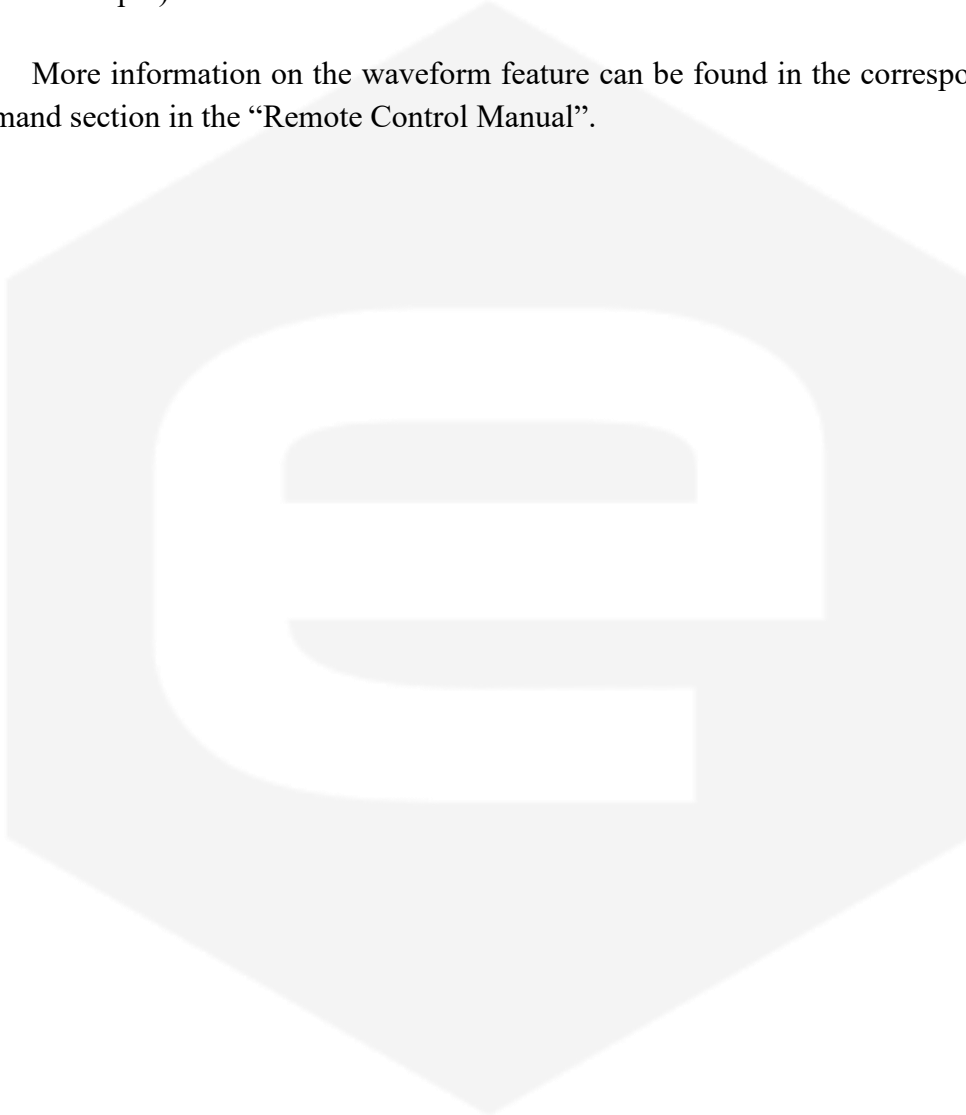

3. Installation

This chapter contains instructions for initial inspection and preparation for use.

3.1 Preparation for use

In order to be operational, the power supply must be connected to an appropriate AC source. The AC source voltage should be within the power supply specification. Do not apply power before reading, Section 3.2, 3.3 and 3.4. Table 5 below, describes the basic setup procedure; follow the instructions in the sequence given to prepare the power supply for use.

Step	Checklist	Description
1	Initial inspection	Physical inspection of power supply
2	Mounting	Installing the power supply, ensuring proper ventilation
3	AC Input Power Connection	Connect the power supply to the AC source
5	Load connection	Wire size selection, Remote Sensing
4	First switch-on	Switch-on checkout procedure

Table 5: Installation checklist

3.2 Initial inspection

Prior to shipment this power supply was inspected and found free of mechanical or electrical defects. Upon unpacking of the power supply, inspect for any damage which may have occurred in transit.

The inspection should confirm that there is no exterior damage to the power supply such as broken switch or connectors and that the all panel and display are not scratched or cracked. Keep all packing material until the inspection has been completed. If damage is detected, compile the RMA form available to the CAEN ELS web site.

3.3 Mounting

The FAST-PS-M module can be used either as a desktop unit or as a rack-mount device since the unit form factor is designed to be installed in a standard 19-inch cabinet.

CAUTION

This power supply is fan cooled, the air intake is at the front panel and the exhaust is at the rear panel. Upon installation allow cooling air to reach the front panel ventilation inlets. Allow minimum 10 cm of unrestricted air space at the front and the rear of the unit.

3.3.1 Rack Mounting

The FAST-PS-M power supply series is designed to fit in a standard 19" equipment rack.

CAUTION

Use a support bar to provide adequate support for the power supply.

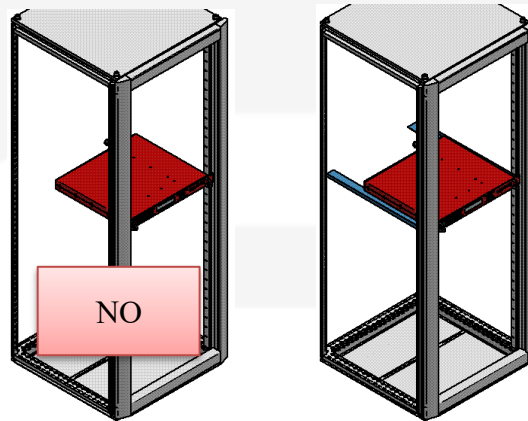

3.3.2 Desktop use

The FAST-PS-M power supply series can be used as desktop unit.

3.4 AC Input Power Connection

The AC line input connector on the rear panel is a standard IEC C14 male inlet socket, with include fuse holder (**Figure 14**).

The required fuses characteristics for all the models are (**T10AL250V**):

- Size: **20 x 5 mm**
- Current rating: **10 A**
- Blow characteristic: **Time delay**
- Breaking Capacity: **35 A**
- AC Voltage rating: **250V**



Figure 14: AC Power Line input socket

3.4.1 AC Source requirement

The FAST-PS-M power supplies are designed for universal AC input range since it can operate with voltage from 100V to 240V and input frequency ranging from 47 Hz to 63 Hz. Installation Category shall be **CAT II** so maximum impulse voltage on the network mains must be below 2500 V.

3.4.2 AC Input Cord

All the FAST-PS power supplies are directly shipped with the corresponding power cord (suitable for the destination country of the purchase). Power supply side connector is a standard IEC C13 plug. Current rating for the connector is 10A. Wire size for detachable power supply cord, not longer than 2 m, shall be at least 0.75 mm². Wire size for fix installation shall be at least 1.5 mm².

WARNING

There is a potential shock hazard if the power supply chassis is not connected to an electrical safety ground via the safety ground in the AC input connector!

WARNING

Turn off the AC input power before making or changing any rear panel connection, Ensure that all connections are securely tightened before applying power. There is a potential shock hazard when using a power supply with a rated output greater than 60 V

3.4.3 Wire selection

Two factors must be considered for the selection of the wires:

- Current carrying capacity -> Cross section area
- Maximum wire length.

- Insulation voltage

Wire cross section and length

Wire size should be selected to enable voltage drop per lead to be less than 1 V at the maximum power supply current to prevent excessive output power consumption. Suggested wire size are listed in the following table:

Wire Cross Section Area [mm ²]	Resistivity [Ω/km]	Maximum Cable length in meters to limit voltage drop to be less than 2 V (1 V per lead)		
		60 A	75 A	100 A
10	1,95	8.5	6.5	5
16	1,24	13.5	10.5	8
25	0,795	20.5	16.5	12.5
35	0,565	29.5	23.5	17.5

Table 6: Wire selection

The cable has to be connected directly to the bass-bar using lug terminals M6 screws. If Table 6 values are used the maximum voltage to the load will be limited to:

FAST-PS-M nominal output voltage + Maximum compensation Voltage if Remote sensing is used – Cable Drop Voltage

Maximum compensation Voltage for all models is 0.5 V

For instance, the FAST-PS-M 10006-600 that have a nominal output voltage of 6 V connected to a load at 8 meter of distance using 2x16 mm² cable can drive at maximum $6 + 0.5 - 2 = 4.5$ V at 100 A on the load.

3.4.4 Remote Sensing

CAUTION

A short from V_{SENS+} or V_{OUT+} to V_{SENS-} or V_{OUT-} will cause damage to the power supply. Reverse the sense wire might cause damage to the power supply in local and remote sensing. Do not connect +S to – or –S to +.

Use remote sense where the load regulation at the load end is critical. In remote sense the power supply will compensate for voltage drop on load wires. Refer to the power supply specification for maximum voltage drop on load wires. The voltage drop

is subtracted from the total voltage available at the output. Follow the instructions below to configure the power supply for remote sensing:

1. Ensure that Mains switch is on Off position “O”
2. Remove factory jumpers between +S to + and –S to –.
3. Using a twisted pair or shielded cable (suggested wire size is 0.3 or 0.5 mm²) connect the +S terminal to the positive output terminal and the –S to the negative output terminal as illustrated in **Figure 15**.

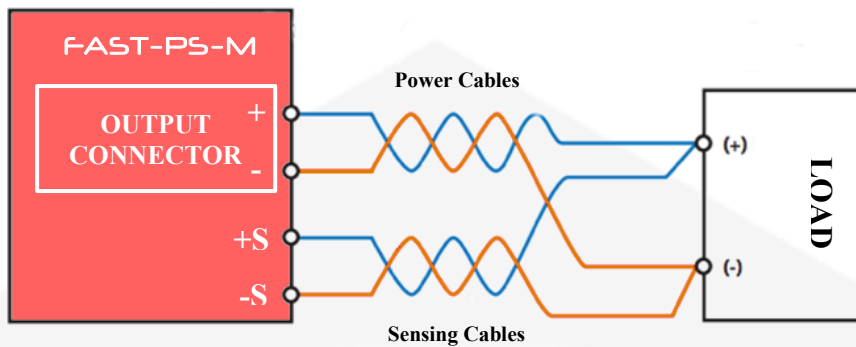
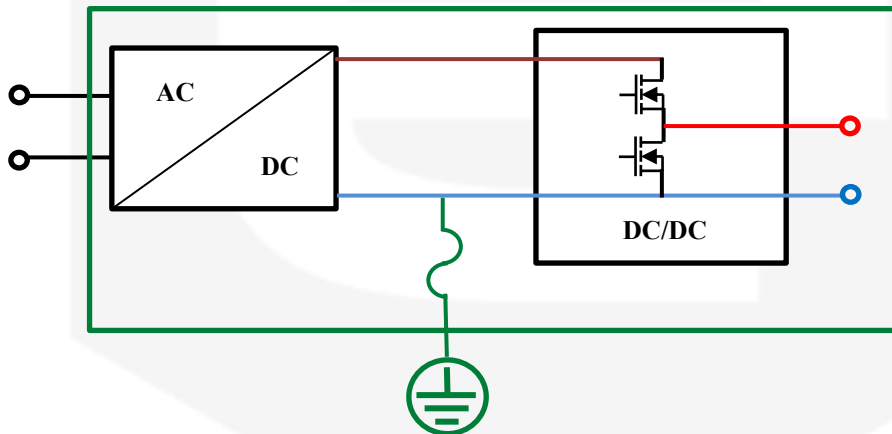

Figure 15: Example of Remote Sensing

3.4.5 Grounding Outputs



The FAST-PS-M is composed by an AC/DC power supply that is providing a constant DC-Link voltage to the output stage. By factory default configuration the minus output terminal is grounded to the Protective Ground (i.e. chassis, Mains-Earth terminal and all metallic parts composing the box) through a fuse. This fuse called Earth Fuse (E.F.) is accessible from the back panel. With this configuration the Output Terminals are not floating and cannot be connected to Protective Ground.

If accidentally one of the output terminals is conducting to the Protective Ground a fault will be triggered switching the power supply Off. Refer to Earth Fuse Fault and Earth Leakage Fault.

To allow floating operation of the output it is sufficient to remove the Earth Fuse from the fuse-holder and set the Power supply for Floating operation.

When the FAST-PS-M is configured to operate in floating mode either the positive or negative output terminals can be grounded. Always use two wires to connect the load to the power supply regardless of how the system is grounded.

WARNING

Output terminals shall not float more than +/-60VDC above/below chassis ground when Earth Fuse is not present.



4. Local Control

This chapter describes the local control functionalities that are provided by the FAST-PS-M power supply and some useful information on how to use it.

The power supply can work either in LOCAL mode or in REMOTE mode. The control mode (LOCAL or REMOTE) can be set on the configuration page of the local display. Remote control is discussed in the “Remote Control Manual” and in the “VISUAL Manual”.

4.1 Navigation Switch

Each FAST-PS-M power supply module is equipped with a Navigation Switch on the front panel of the unit as shown in the following **Figure 16**:



Figure 16: Navigation switch

There are multiple actions that can be performed via this front navigation switch:

- Left, Right, Up, Down arrow pushbuttons;
- Internal encoder rotation (CW and CCW);
- Central pushbutton (it will also be referred to as “Enter”).

4.2 Display

The colour display on the FAST-PS-M power supply unit allows users to visualize information about the power supply status and to control the unit in order to use it locally. Screens and pages of the display can be navigated from the navigation switch through user friendly menus and sub-menus.

By default, the display will be automatically turned off after 30 minutes from the last local command or from the turning on of the power supply.

The user can disable this feature or change the turning off time; for more information, please refer to the “Remote Control Manual”.

4.2.1 Power-up

The FAST-PS-M, upon power-up or power-cycling, will display an empty screen until the unit embedded OS is initialized.

Please note that this procedure will take approximately 25-seconds before the Home Screen is displayed.

4.2.2 Home Screen

The FAST-PS-M home screen is the first loaded page upon power-up or power-cycling of the module, it is shown in **Figure 17**, and contains information on:

- the FAST-PS-M model;
- the module IP address;
- output current readback value [A] with the light blue status bar;
- output voltage readback value [V] with the green status bar;
- the status of the output – i.e. ON or OFF;
- the status of the control – i.e. Local or Remote;
- the module Identification Name;
- the regulation mode of the unit – i.e. constant-current or constant-voltage.



Figure 17: Home Screen

The Home screen presents some indications on the right side as:

- **ON – OFF**: shows if the power supply output is enabled or not;
- **REM – LOC – FCI**: shows if the module is in Local, Remote or Fast Control Interface control mode;
- **C.C. – C.V.**: shows if the module is working in C.C. or in C.V. regulation mode.
- **NOR – WAV – TRG – AIN**: shows the selected update mode.

An example of the indications on the right side of the Home screen is hereafter shown in **Figure 18**:



Figure 18: Home Screen indicators

If the module has experienced one or more faults – e.g. interlock intervention, over-temperature, etc. – the home page screen would display a list of the faults, turning also the module OFF.

The power supply latches on every fault recognized by the internal logic so that every type of fault is recorded: this means that the first fault happening does not ban the other ones to be recorded so that, giving users more information, permits a better investigation of the fault cause.

4.2.3 Menu Page

The Menu page is reachable by performing any action on the navigation switch when in the *Home Screen*.

The Menu Page gives access to all the local features of the FAST-PS-M power supply unit. There are five different options that can be selected as shown in **Figure 19**:

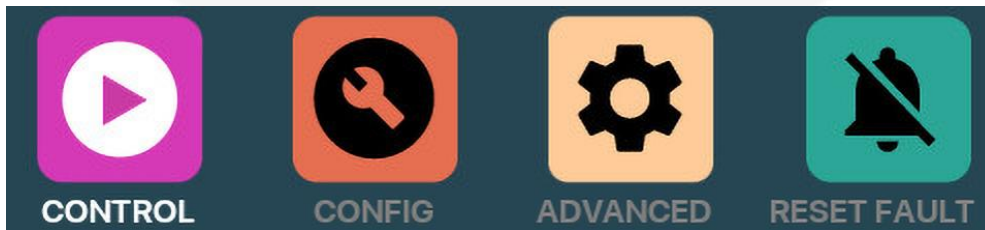

Figure 19: Menu Page

The accessible sub-pages and/or actions from this page are hereafter listed (note that the selected sub-menu is lightened in a lighter shade):

- **Control** – *sub-page*;
- **Config** – *sub-page*;
- **Advanced** – *sub-page*;
- **Reset faults** - *action*;
- **Return to main** - *action*.

The access to each sub-menu (or action) is necessary to highlight the selected rectangle by using the encoder or the arrows of the navigation switch and press the “Enter” button.

The **Reset faults** rectangle, once pressed, resets the status register of the power supply and sends back to the visualization of the *Home Screen*.

The **Return to main** rectangle, once pressed, sends back the visualization to the *Home Screen*.

4.2.3.1 *Control Page*

The *Control Page* is reachable by selecting the corresponding rectangle from the *Menu Page*.

The *Control Page* gives access to the main settings of the FAST-PS power supply unit. An example of a *Control Page* visualization is shown in **Figure 20**:



Figure 20: *Control Page*

From this screen it is possible to turn the power supply unit ON and OFF and to set the output current or voltage (depending on the regulation type, C.C. or C.V.).

Actual values of output current and output voltage (readbacks) can also be seen at the bottom line of this page.

4.2.3.2 Config Page

The *Config Page* is reachable by selecting the corresponding rectangle from the *Menu Page*.

This page allows the user to set the control mode of the power supply – e.g. LOCAL or REMOTE – to select the regulation mode (C.C. or C.V.) and to set the slew rate in [A/s] or [V/s] depending on the selected regulation mode.

An example of a *Config Page* visualization is shown in **Figure 21**:

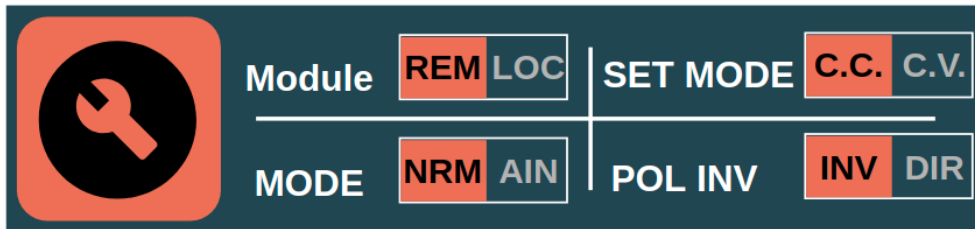

Figure 21: *Config Page*

The firmware installed version is shown at the bottom of this page (FW Version).

4.2.3.3 Advanced Page

The *Advanced Page* is reachable by selecting the corresponding rectangle from the *Menu Page*.

This page allows to locally set the power supply Ethernet IP address, the Network Mas and the Gateway.

In alternative, the user may select “DHCP ON” and the Network configuration will be automatically assigned by DHCP server (if present).

An example of an *Advanced Page* visualization is shown in **Figure 22**:

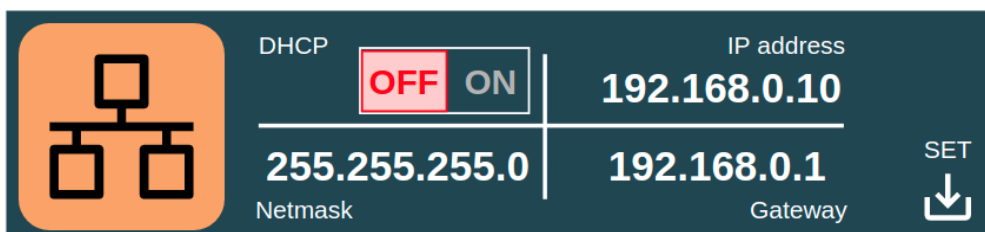

Figure 22: *Advanced Page*

It is very important to notice that once the "OK" button has been clicked, the user can remotely communicate and get control of the power supply again only by opening a new TCP socket to the IP that has just been set.

5. Mechanical Dimensions

The mechanical dimensions of the FAST-PS-M units are hereafter presented (in units of mm) in **Figure 23**:

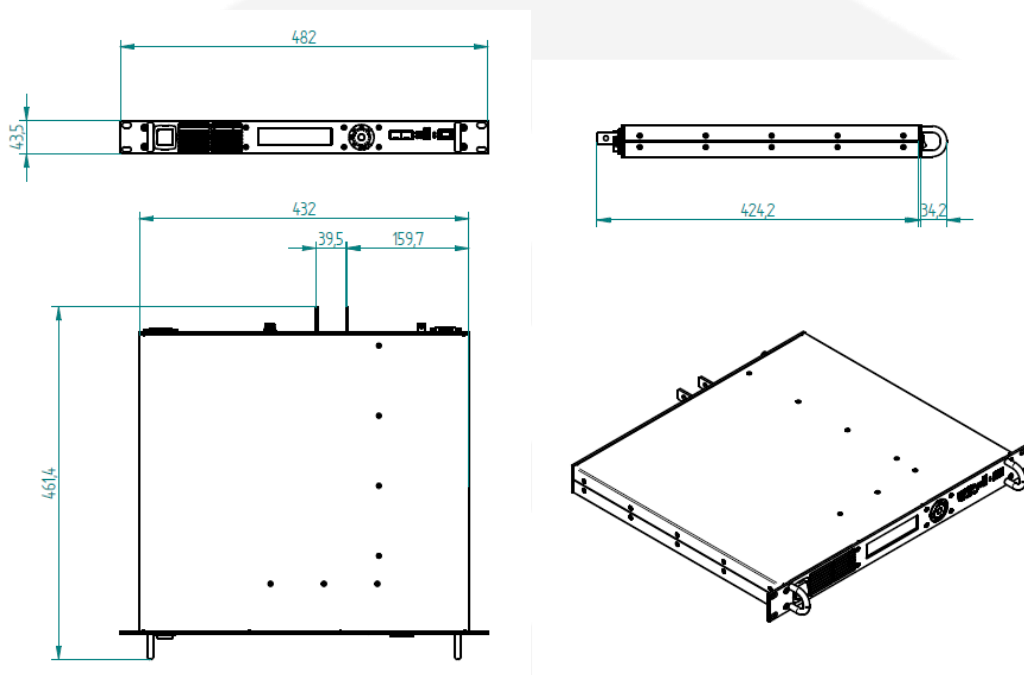
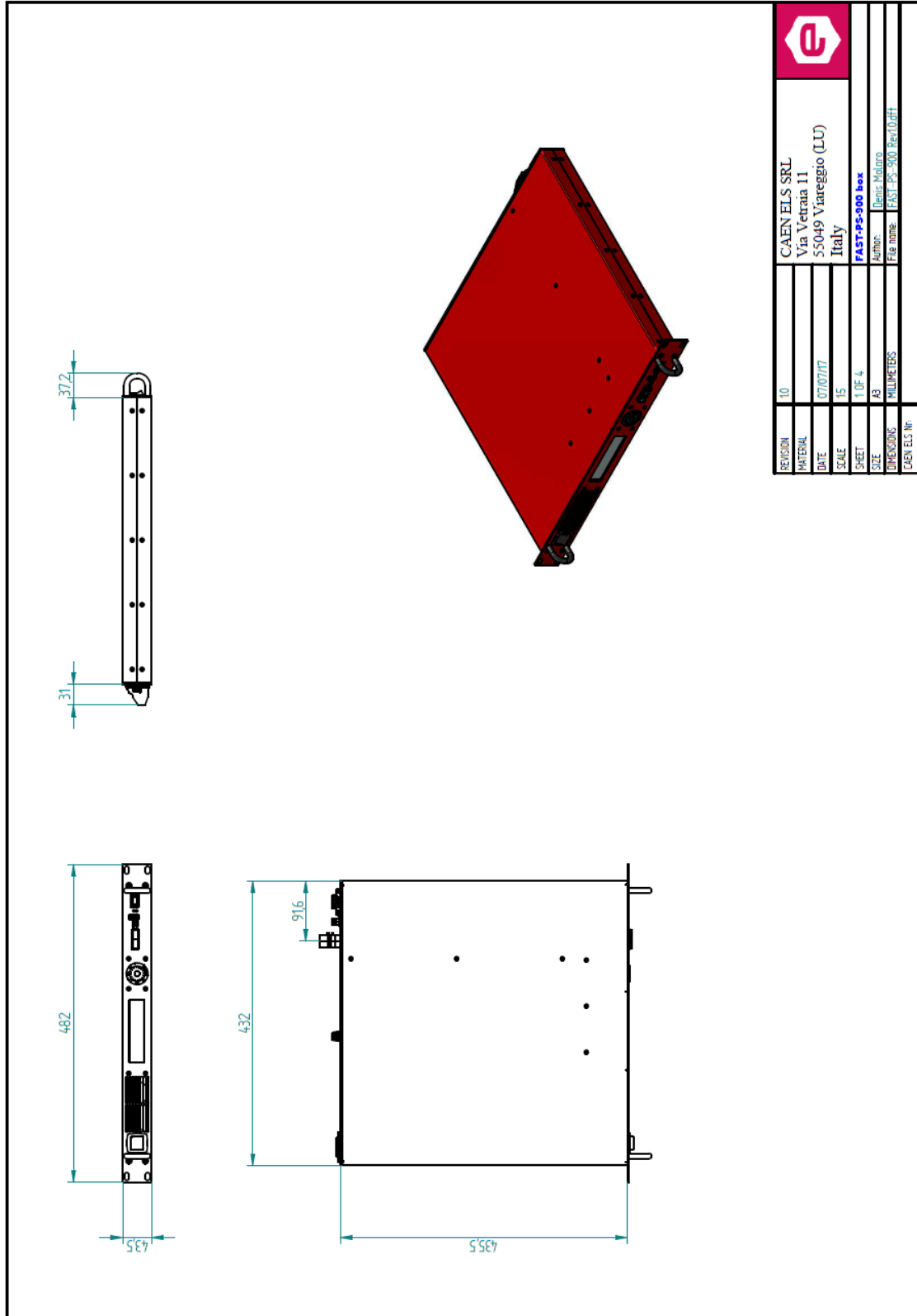

Figure 23: FAST-PS Mechanical Drawings

5.1 FAST-PS-M 3030 Mechanical Dimensions

The FAST PS M 3030 has different dimensions with respect to the other monopolar models, which are reported hereafter:



6. Technical Specifications

The main technical specifications for the FAST-PS-M models are hereafter presented:

Technical Specifications	FAST-PS-M
Output current range	30 A 60 A 75 A 100 A
Output voltage range	30 V 10 V 8 V 6 V
Maximum output power	600W 900W (FAST-PS-M 3030)
Regulation Type	Current- or Voltage- Control
Current setting resolution	18 bit
Voltage setting resolution	18 bit
Output current readback	24 bit
Output voltage readback	24 bit
Output current ripple*	30 ppm / FS
Output current stability	50 ppm / FS
Output voltage stability	50 ppm / FS
Switching Frequency	100 kHz
Max Current/Voltage update rate (SFP/SFP+)	10 kHz
Accuracy	< 0.05%
External Interlock/States	2 Inputs: user-configurable “dry” contacts 1 Output: magnetic relay-type (3 contacts)
Internal Interlocks	DC Link Under-Voltage Over-Temperature Input Over-Current DCCT OK Earth Leakage Current Regulation Fault
Hardware protections	Input fuses Earth fuse

Technical Specifications	FAST-PS-M
	Over-Voltage
Auxiliary ADC Read-Backs (16 bit resolution)	DC Link Voltage Ground Leakage Current Heatsink Temperature DCCT Temperature
Cooling	On-module self-regulated fans
Drivers	EPICS
Communication interfaces	1x Ethernet 10/100/1000 TCP-IP 2x SFP ports
Extra-features	Point-by-point current waveform User-definable interlock thresholds, active levels and timings Firmware remote update Analog control input (0-10 V, 1 kHz) - <i>optional</i>
Dimensions	19” wide – 1U high rack – 400 mm deep
Input Nominal Voltage	100-240 VAC 50-60 Hz
Input Range Voltage	90-260 VAC 50-60 Hz
Efficiency	up to 85%
Weight	< 8 kg
Local Control / Monitor	Graphic Display and Encoder 4 LEDs

Table 7: Technical Specifications