



PROCEDURE FOR ADAPTING THE PID PARAMETERS FOR THE *Easy-Driver*

>> Pre-Information

THE Easy Driver is a digitally controlled power supply. This means that an adaptation to any load can be achieved simply by changing the Software PID-Parameters.

Easy-Driver power supply a have control loop that continuously controls current. Current Control Loop diagram is hereafter presented:

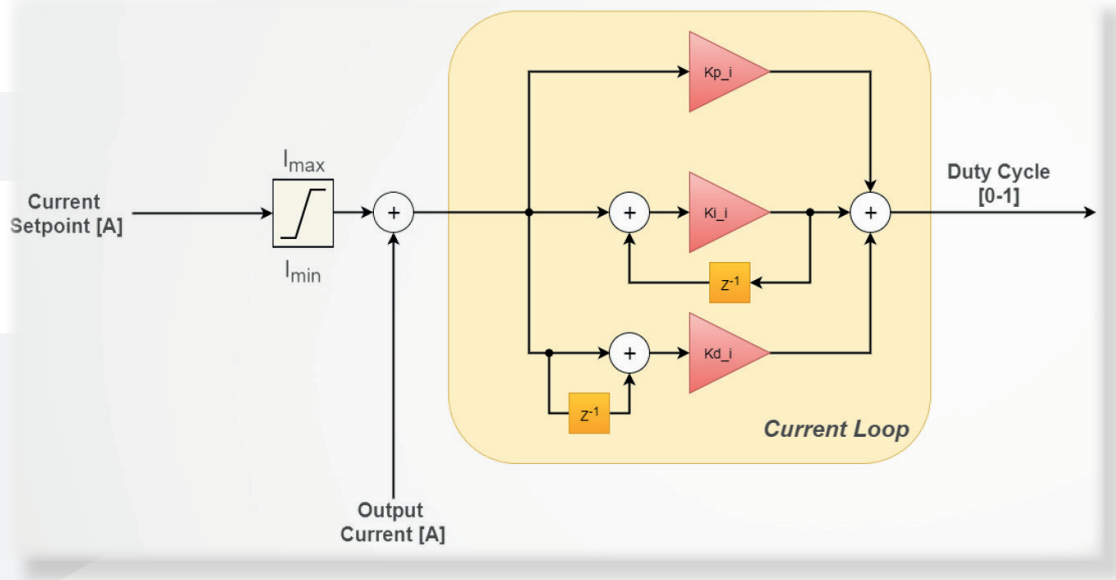

The PID-parameters consist in 3 values, Kp, Ki and Kd, that can be input through the Visual Easy Driver software.



PID PARAMETER ADAPTATION



From the **Visual Easy-Driver** main menu:

- Go to **Settings** menu and enter the power supply's IP address .
- Click on **PS Memory** to access the PID settings.

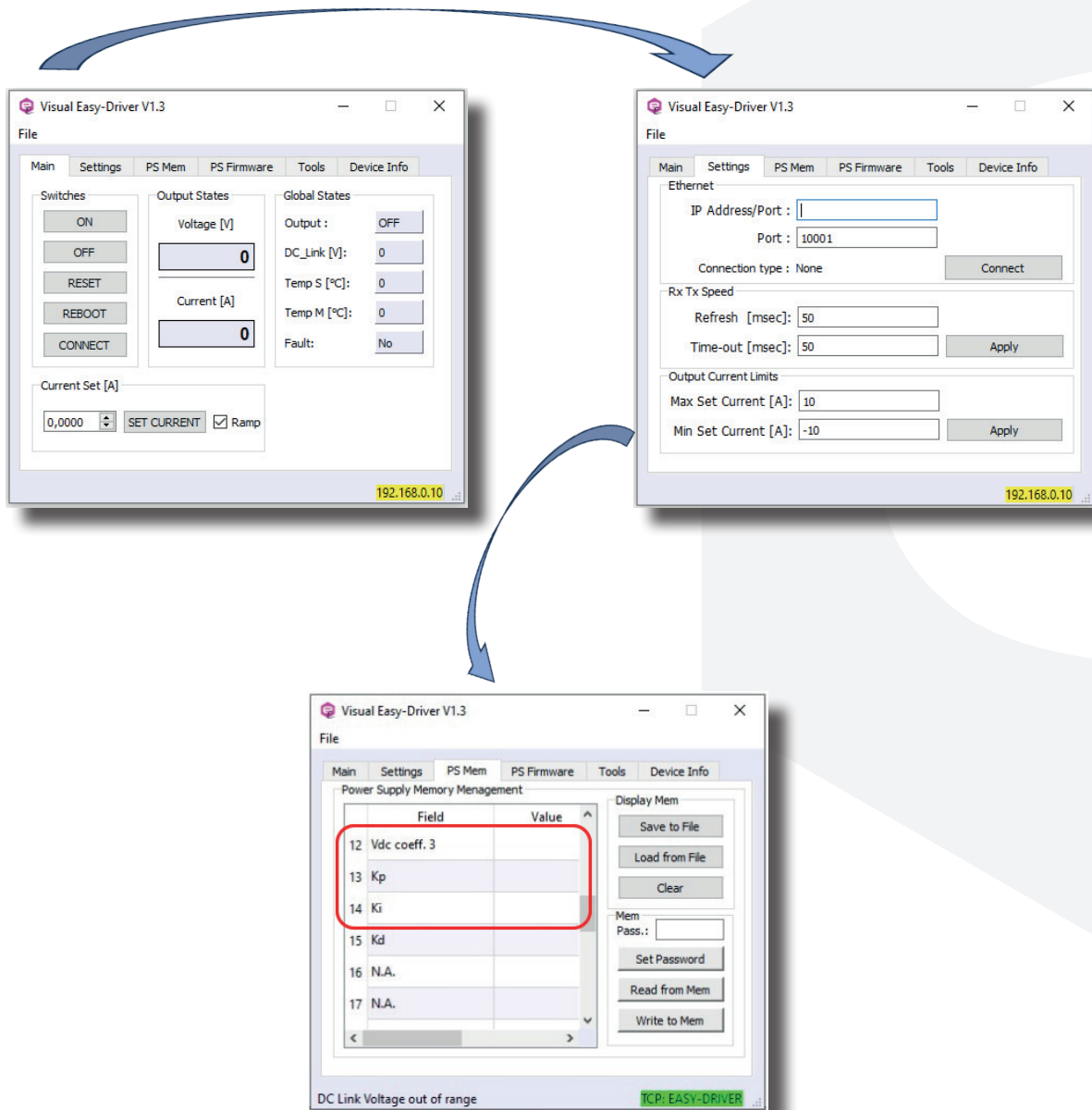

- Press the **Write to Mem** button to save the values to the internal memory.

PID PARAMETER ADAPTATION



Target is to adapt PID values for a specific load connected to the **Easy-Driver** that is performing in an ideal way: Fast Rise Times, No Overshoot (or small Overshoot), No Oscillations.

UNWANTED STEP RESPONSE:

NO

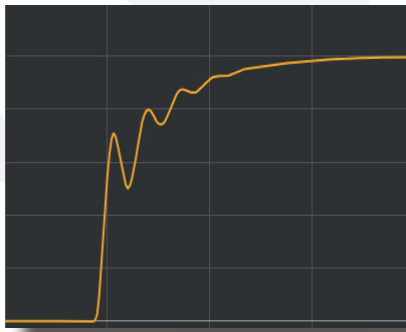

NO



DESIDERABLE STEP RESPONSE:

YES

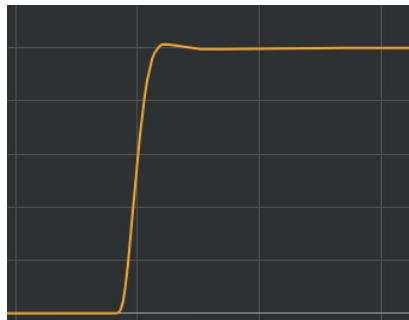

PID PARAMETER ADAPTATION

Setup Devices



Easy-Driver connected to the Load



CT-100 – current sensor clamp; for instance and **PSI2151**
(or another setup for measuring current)

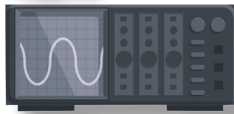

Oscilloscope



Differential Probe to measure the output Voltage

Connect the devices as describe in the following diagram:

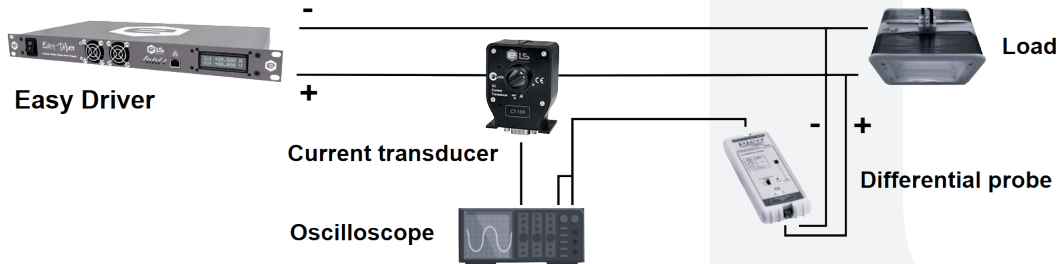

PID Adaption-Procedure

Due to safety concerns for both the source and the load, caused by potential dangerous high-frequency oscillations, the PID parameters should be set to very low values at the beginning of each adaptation for an unknown load.

To proceed follow these steps:

1. It is recommended to start with these parameters (safe side):

$$K_p = K_i = 0.00001 \text{ and } K_d = 0$$

2. (K_d typically should not to be changed due to its minor influence on the result. Only in very special cases with exceptionally high demands, such as with superconducting magnets, might it be adjust).
3. During PID adaptation procedure, set current to approximately **10%** of the nominal value. (i.e. if the Easy Driver is a 10A - 20 V model set Current and Voltage from 0 to 1A).

ATTENTION: The PID parameters are specific to each power source series. For example, it is not possible to use the same parameters for a Easy Driver 0220A that were determined for the Easy-Driver1020A!

PID PARAMETER ADAPTATION



In the following figures the current is represented in yellow and voltage in red.

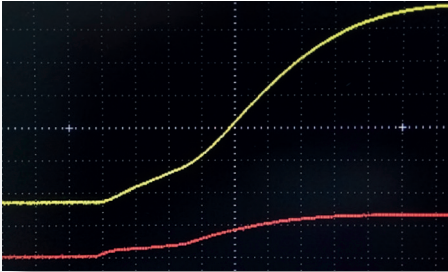

Fig. A

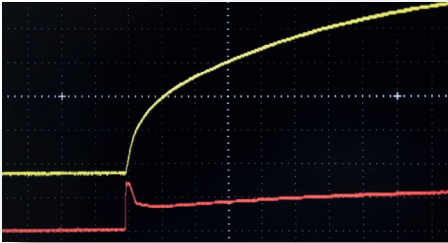

Fig. B

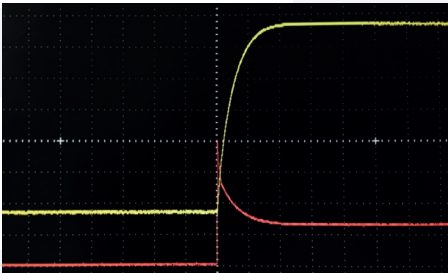

Fig. C

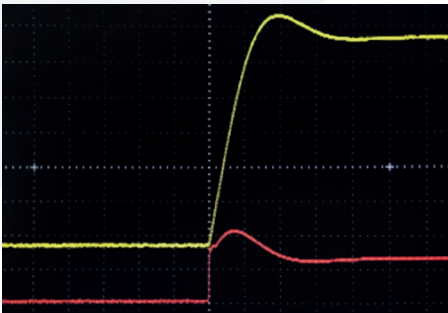
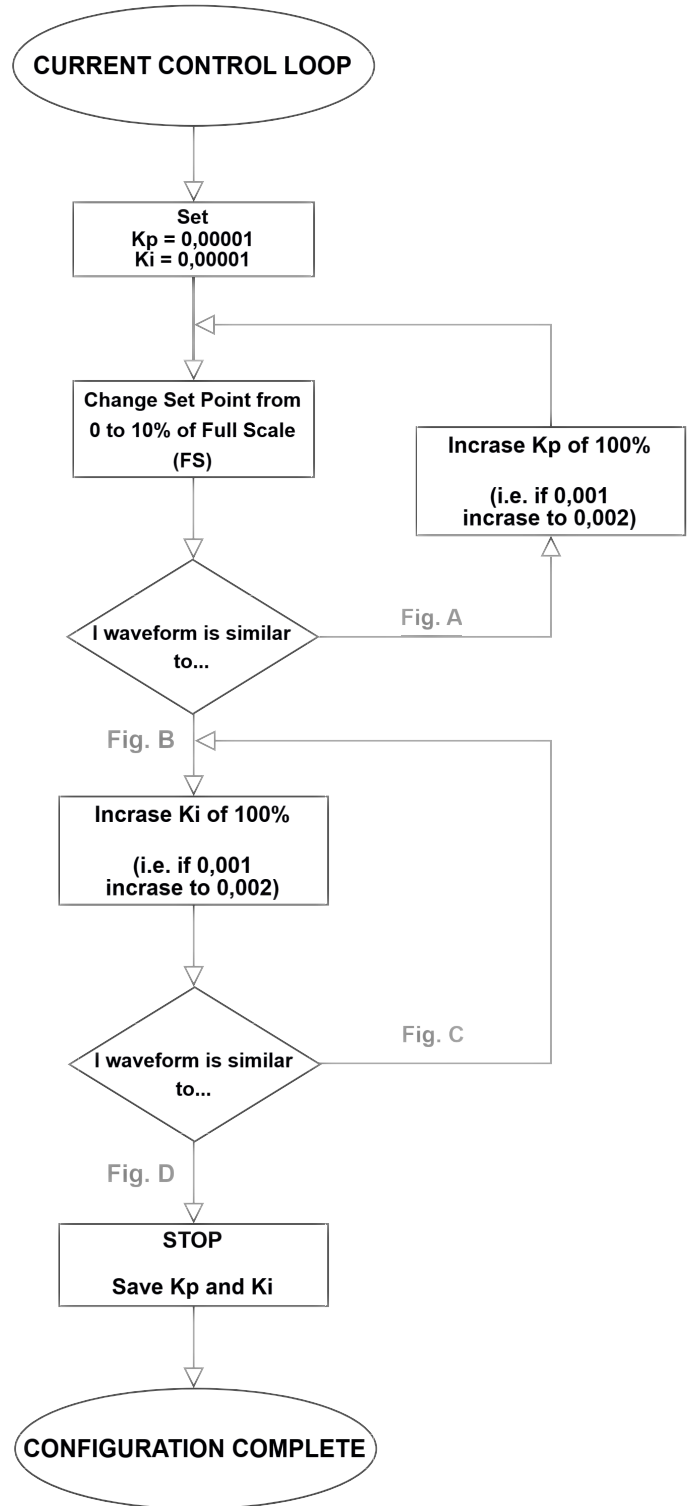

Fig. D



NOTE: In some cases when Fig.D is obtained, a further increase of Kp may reduce the overshoot.







PID PARAMETER ADAPTATION



About Us

ELS Instruments (formerly CAEN ELS) is a leading company in the design of power supplies and state-of-the-art complete electronic systems for the Physics research world, having its main focus on dedicated solutions for the particle accelerator community and high-end industrial applications.

-  Power Supply Systems
-  Precision Current Measurements
-  Beamline Electronics Instrumentation
-  FMC and MicroTCA

ELS Instruments srl

Via Karl Ludwig von Bruck 32
34144 - Trieste (TS) Italy

info@caenels.com

www.els-instruments.com

www.caenels.com

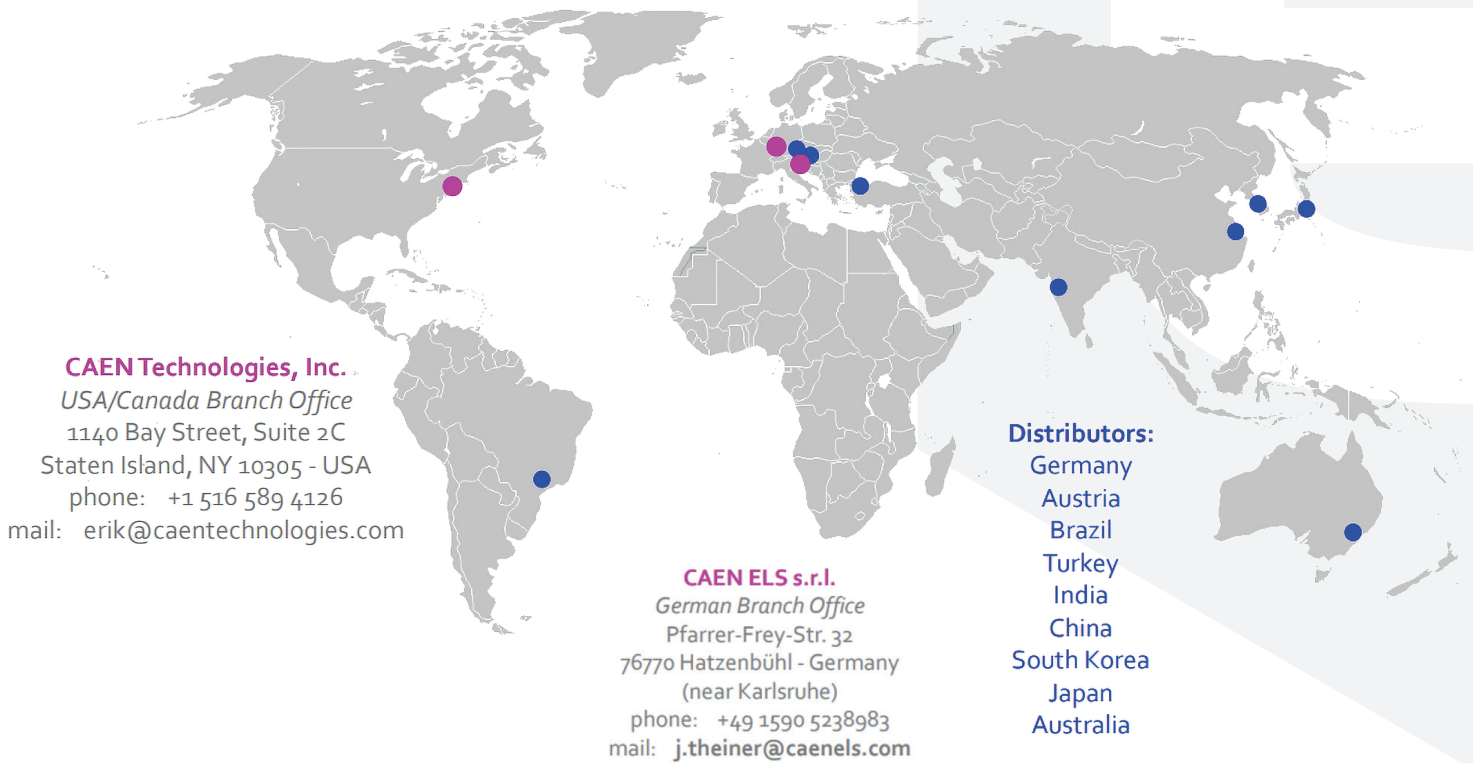

CAEN Technologies, Inc.

USA/Canada Branch Office
1140 Bay Street, Suite 2C
Staten Island, NY 10305 - USA
phone: +1 516 589 4126
mail: erik@caentechnologies.com

CAEN ELS s.r.l.

German Branch Office
Pfarrer-Frey-Str. 32
76770 Hatzenbühl - Germany
(near Karlsruhe)
phone: +49 1590 5238983
mail: j.theiner@caenels.com

Distributors:

Germany
Austria
Brazil
Turkey
India
China
South Korea
Japan
Australia
...



Copyright © ELS Instruments srl - 2026

All rights reserved. Information in this publication supersedes all previous versions.
Specifications subject to change without notice.

Rev. 1.2 - Printed in May 2026